



Νευρο-Ασαφής Υπολογιστική Neuro-Fuzzy Computing

Διδάσκων –
Δημήτριος Κατσαρός

@ Τμ. ΗΜΜΥ
Πανεπιστήμιο Θεσσαλίας

Διάλεξη 24^η: Transformers-II



Transformers

[Attention mechanisms]





A high-Level look of a transformer

- Let's begin by looking at the model as a single black box, in a machine translation application, i.e., it would take a sentence in one language, and output its translation in another

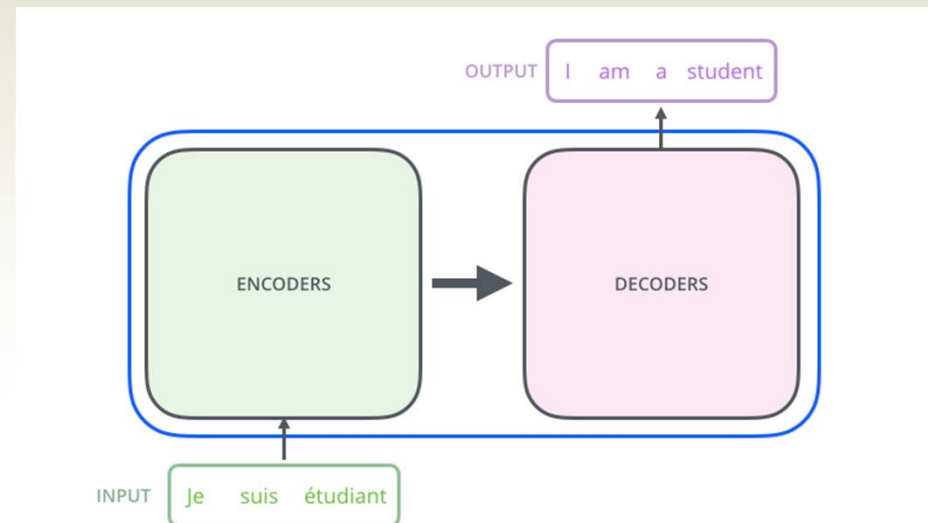
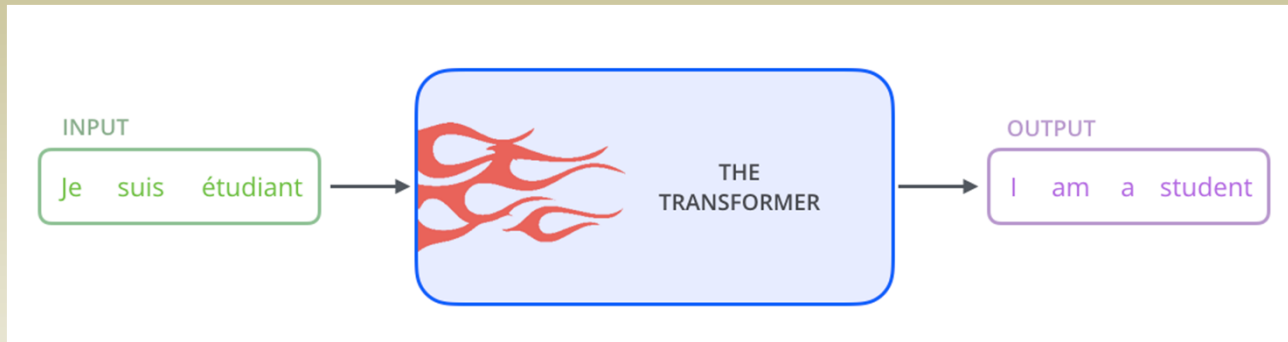



A high-Level look of a transformer

- The encoding component is a stack of encoders (here we stack six of them on top of each other –one can definitely experiment with other arrangements). The decoding component is a stack of decoders of the same number

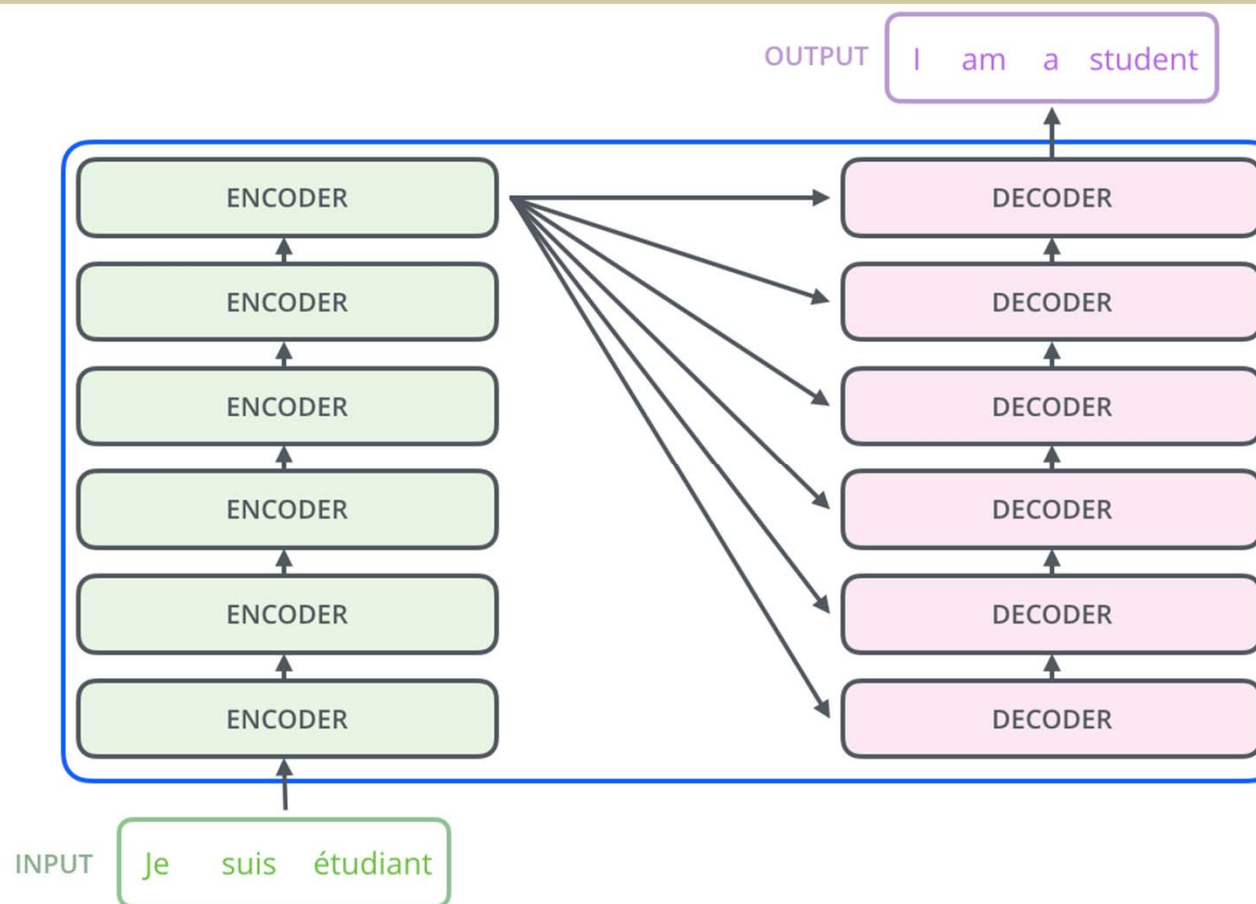



A high-Level look of a transformer

- The encoders are all identical in structure (yet they do not share weights). Each one is broken down into two sub-layers:

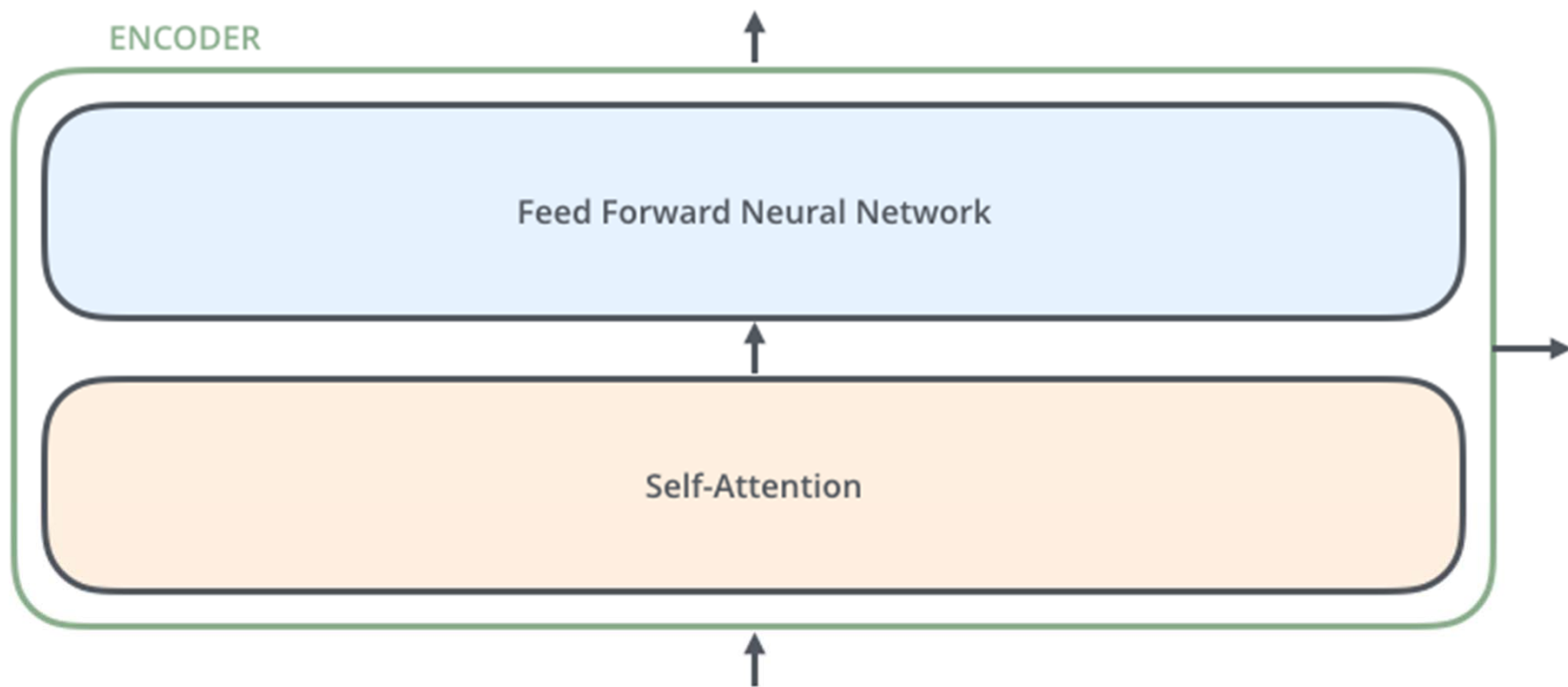

A high-Level look of a transformer

- The encoder's inputs first flow through a self-attention layer – a layer that helps the encoder look at other words in the input sentence as it encodes a specific word. We'll look closer at self-attention later
- The outputs of the self-attention layer are fed to a feed-forward neural network. The exact same feed-forward network is independently applied to each position
- The decoder has both those layers, but between them is an attention layer that helps the decoder focus on relevant parts of the input sentence (similar what attention does in seq2seq models)

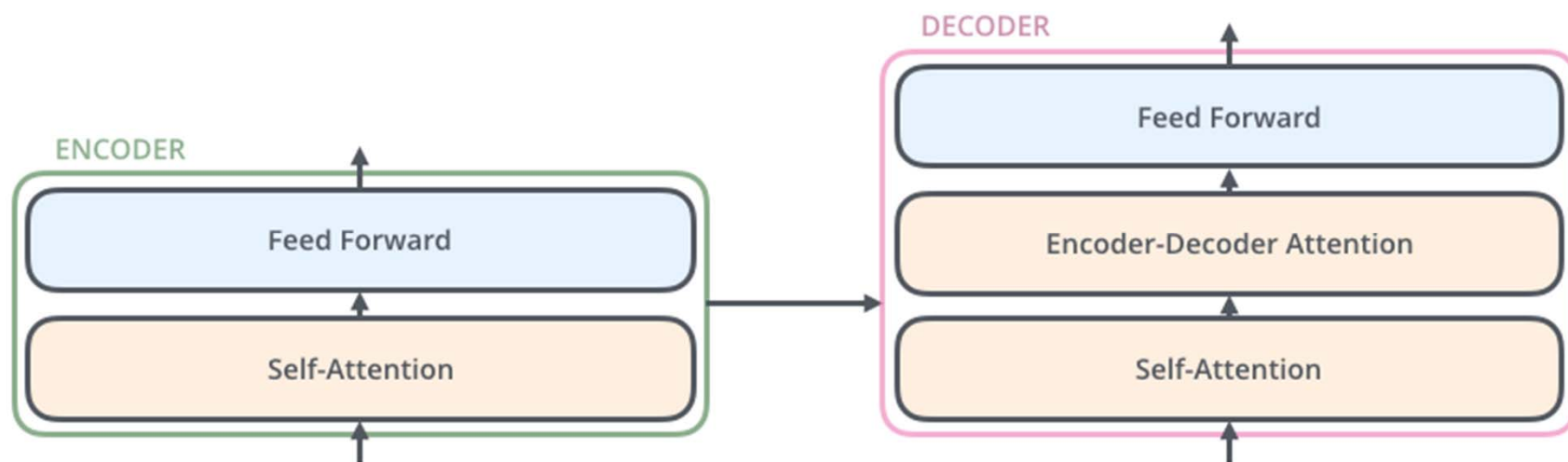



The tensors

- Now that we have seen the major components of the model, let's start to look at the various vectors/tensors and how they flow between these components to turn the input of a trained model into an output
- As is the case in NLP applications in general, we begin by turning each input word into a vector using an embedding algorithm



Each word is embedded into a vector of size 512. We'll represent those vectors with these simple boxes

- The embedding only happens in the bottom-most encoder. The abstraction that is common to all the encoders is that they receive a list of vectors each of the size 512 – In the bottom encoder that would be the word embeddings, but in other encoders, it would be the output of the encoder that's directly below. The size of this list is hyperparameter we can set – basically it would be the length of the longest sentence in our training dataset



The tensors

- After embedding the words in our input sequence, each of them flows through each of the two layers of the encoder.

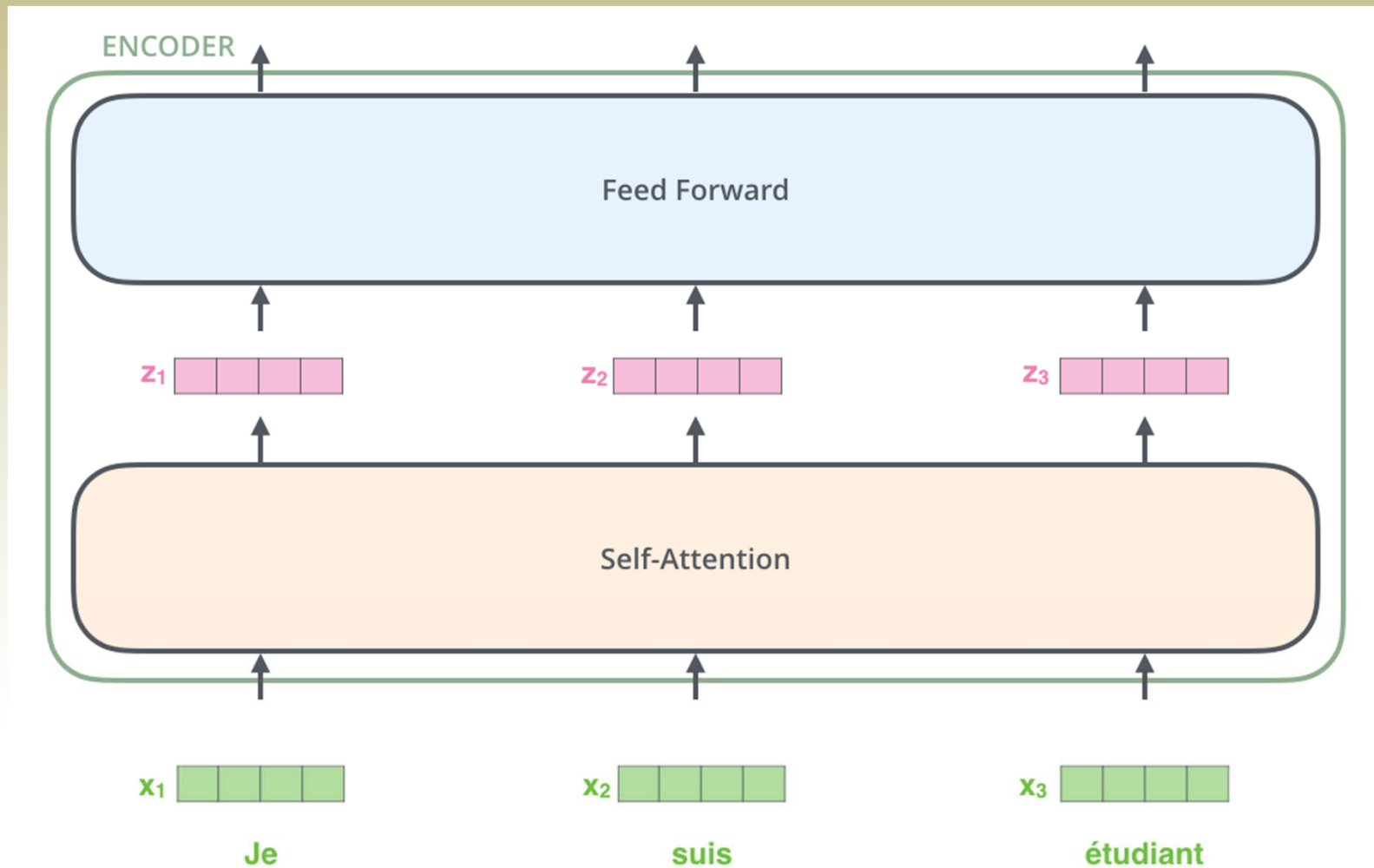



The tensors

- We begin to see one key property of the Transformer, which is that the word in each position flows through its own path in the encoder
- There are dependencies between these paths in the self-attention layer. The feed-forward layer does not have those dependencies, however, and thus the various paths can be executed in parallel while flowing through the feed-forward layer
- Next, we'll switch up the example to a shorter sentence and we'll look at what happens in each sub-layer of the encoder

Encoding

- As we've mentioned already, an encoder receives a list of vectors as input. It processes this list by passing these vectors into a 'self-attention' layer, then into a feed-forward neural network, then sends out the output upwards to the next encoder

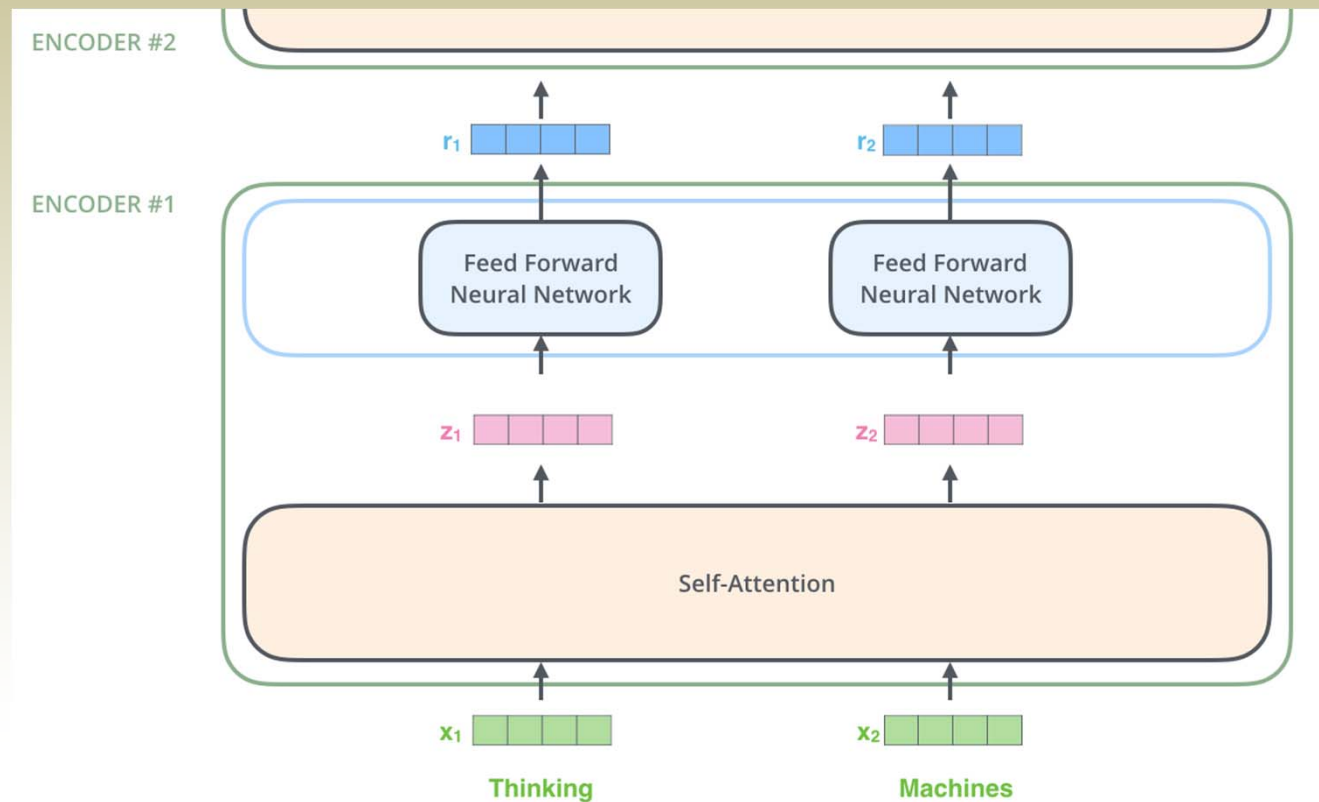

The word at each position passes through a self-attention process. Then, they each pass through a feed-forward neural network -- the exact same network with each vector flowing through it separately.



Self-attention at a high level

- Say the following sentence is an input sentence we want to translate:
 “The animal didn't cross the street because it was too tired”
- What does “it” in this sentence refer to? Is it referring to the street or to the animal? It’s a simple question to a human, but not as simple to an algorithm
- When the model is processing the word “it”, self-attention allows it to associate “it” with “animal”
- As the model processes each word (each position in the input sequence), self attention allows it to look at other positions in the input sequence for clues that can help lead to a better encoding for this word
- You’re familiar with RNNs, so think of how maintaining a hidden state allows an RNN to incorporate its representation of previous words/vectors it has processed with the current one it’s processing. Self-attention is the method the Transformer uses to bake the “understanding” of other relevant words into the one we’re currently processing



Self-attention at a high level

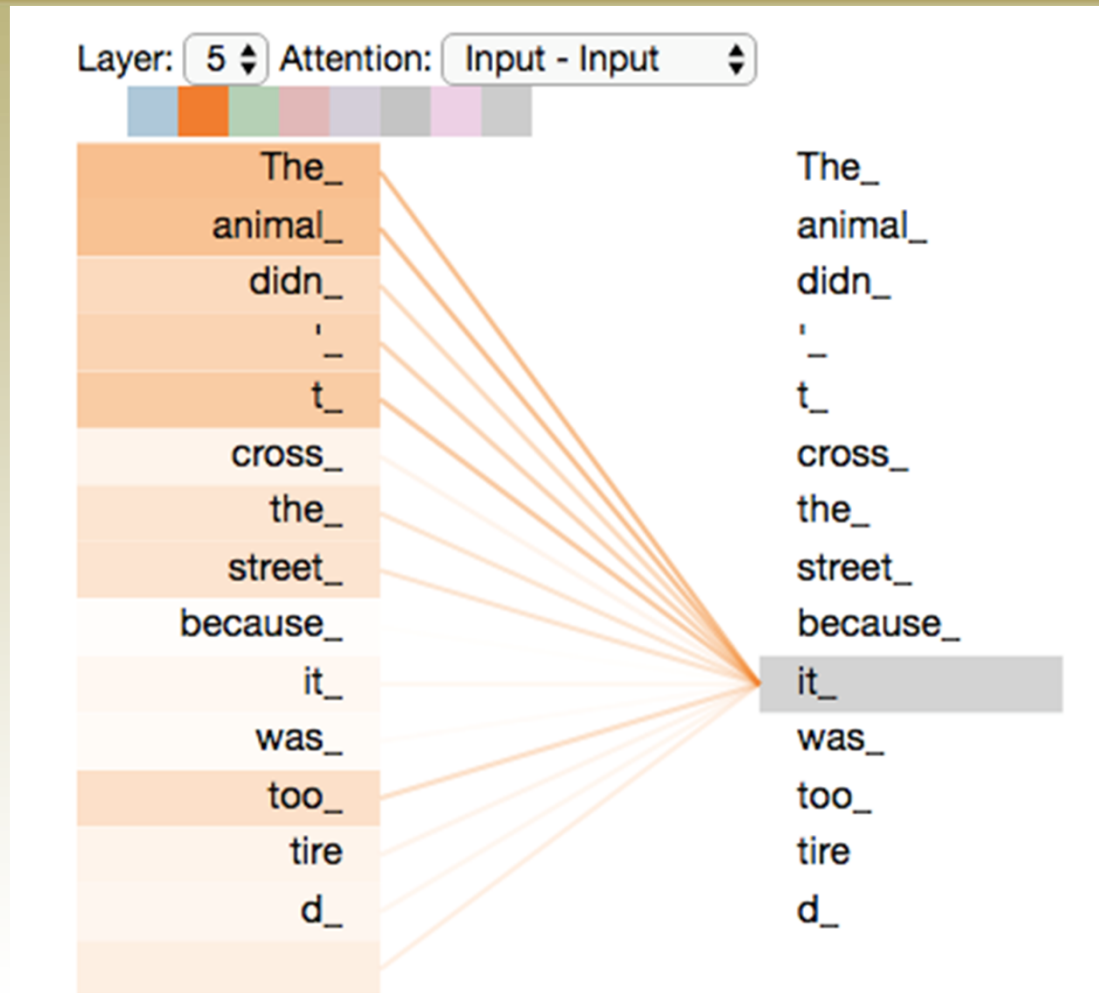

As we are encoding the word "it" in encoder #5 (the top encoder in the stack), part of the attention mechanism was focusing on "The Animal", and baked a part of its representation into the encoding of "it".



Self-attention in detail

- Let's first look at how to calculate self-attention using vectors, then proceed to look at how it's actually implemented – using matrices
- The first step in calculating self-attention is to create three vectors from each of the encoder's input vectors (in this case, the embedding of each word). So for each word, we create a Query vector, a Key vector, and a Value vector. These vectors are created by multiplying the embedding by three matrices that we trained during the training process
- Notice that these new vectors are smaller in dimension than the embedding vector. Their dimensionality is 64, while the embedding and encoder input/output vectors have dimensionality of 512. They don't HAVE to be smaller, this is an architecture choice to make the computation of multiheaded attention (mostly) constant.

Self-attention in detail

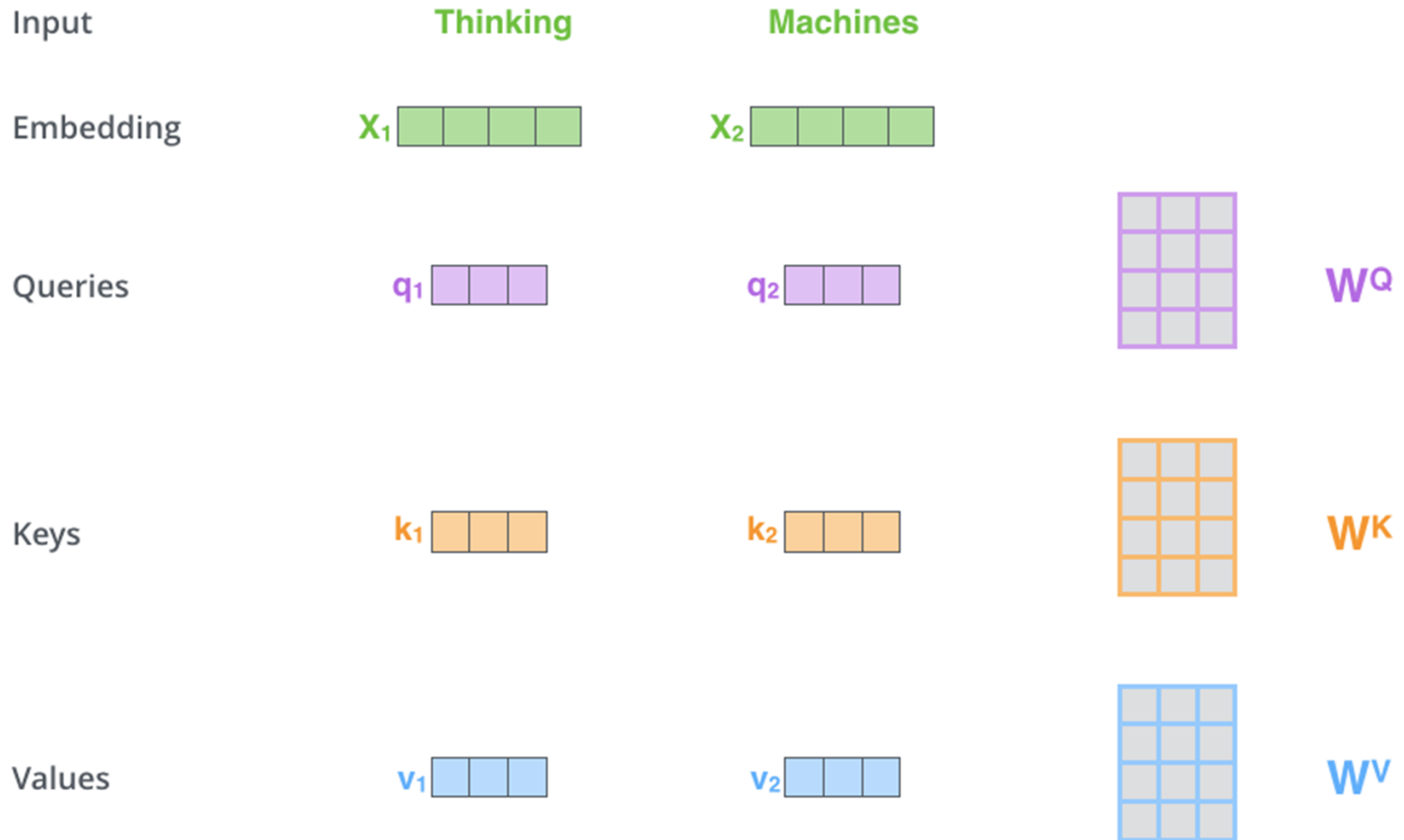

Multiplying x_1 by the W^Q weight matrix produces q_1 , the "query" vector associated with that word. We end up creating a "query", a "key", and a "value" projection of each word in the input sentence



Self-attention in detail

- What are the “query”, “key”, and “value” vectors?
- They’re abstractions that are useful for calculating and thinking about attention. Once you proceed with reading how attention is calculated below, you’ll know pretty much all you need to know about the role each of these vectors plays



Self-attention in detail

- The second step in calculating self-attention is to calculate a score. Say we're calculating the self-attention for the first word in this example, "Thinking". We need to score each word of the input sentence against this word. The score determines how much focus to place on other parts of the input sentence as we encode a word at a certain position
- The score is calculated by taking the dot product of the query vector with the key vector of the respective word we're scoring. So if we're processing the self-attention for the word in position #1, the first score would be the dot product of q_1 and k_1 . The second score would be the dot product of q_1 and k_2

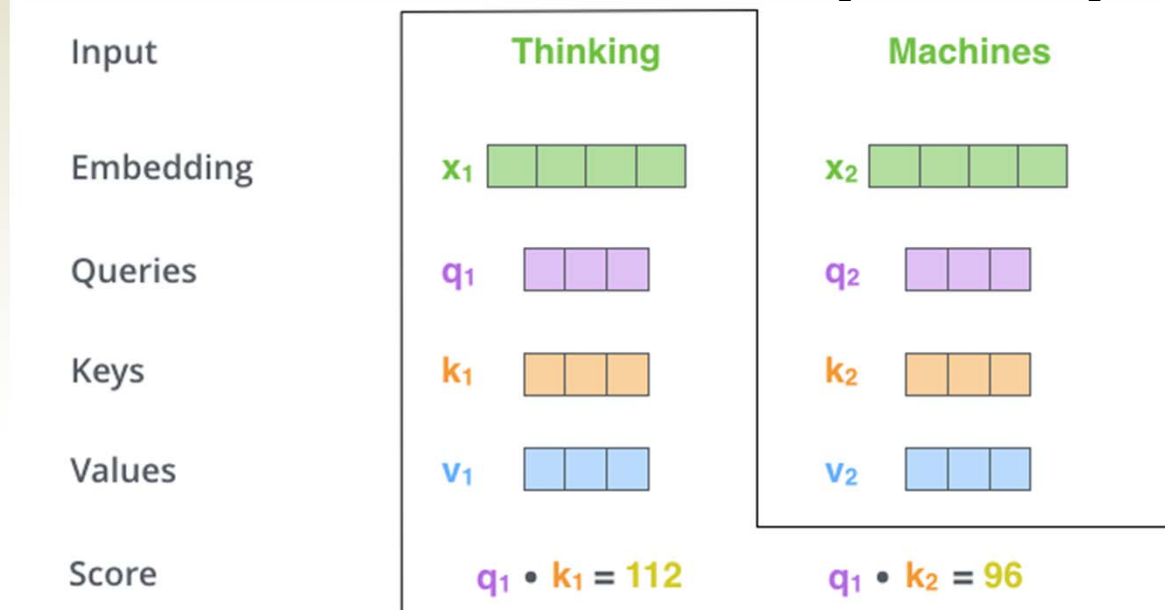



Self-attention in detail

- The third and fourth steps are to divide the scores by 8 (the square root of the dimension of the key vectors used in the paper – 64. This leads to having more stable gradients. There could be other possible values here, but this is the default), then pass the result through a softmax operation. Softmax normalizes the scores so they're all positive and add up to 1
- This softmax score determines how much each word will be expressed at this position. Clearly the word at this position will have the highest softmax score, but sometimes it's useful to attend to another word that is relevant to the current word

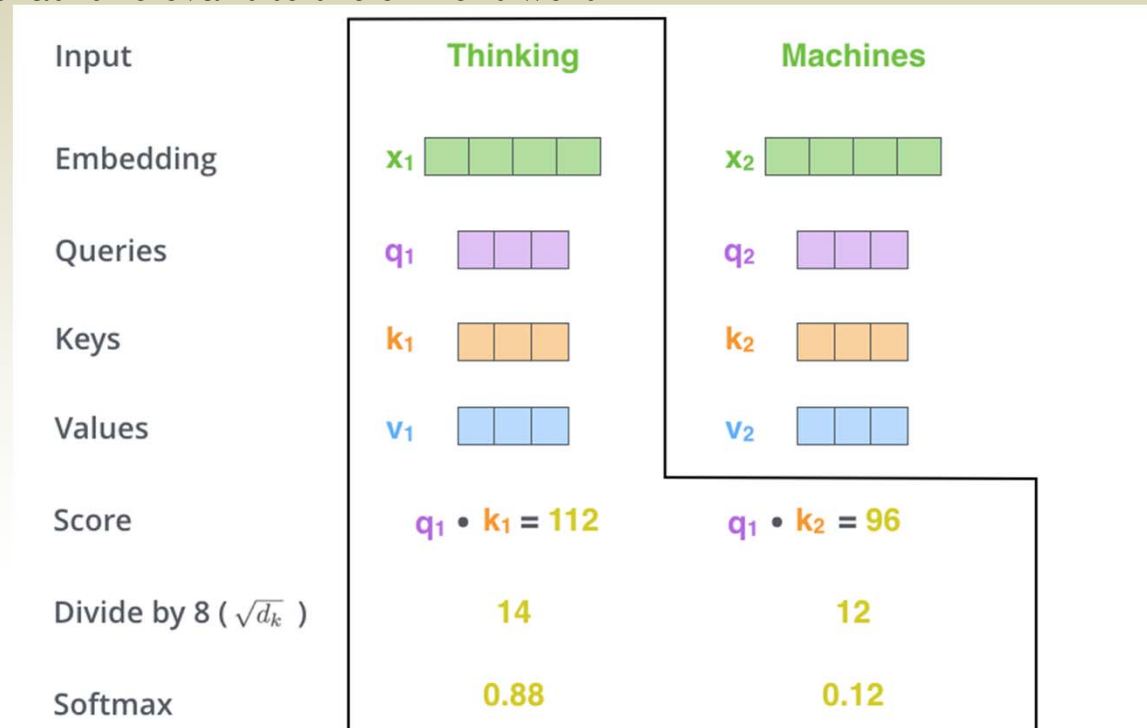



Self-attention in detail

- The fifth step is to multiply each value vector by the softmax score (in preparation to sum them up). The intuition here is to keep intact the values of the word(s) we want to focus on, and drown-out irrelevant words (by multiplying them by tiny numbers like 0.001, for example)
- The sixth step is to sum up the weighted value vectors. This produces the output of the self-attention layer at this position (for the first word)
- That concludes the self-attention calculation. The resulting vector is one we can send along to the feed-forward neural network. In the actual implementation, however, this calculation is done in matrix form.

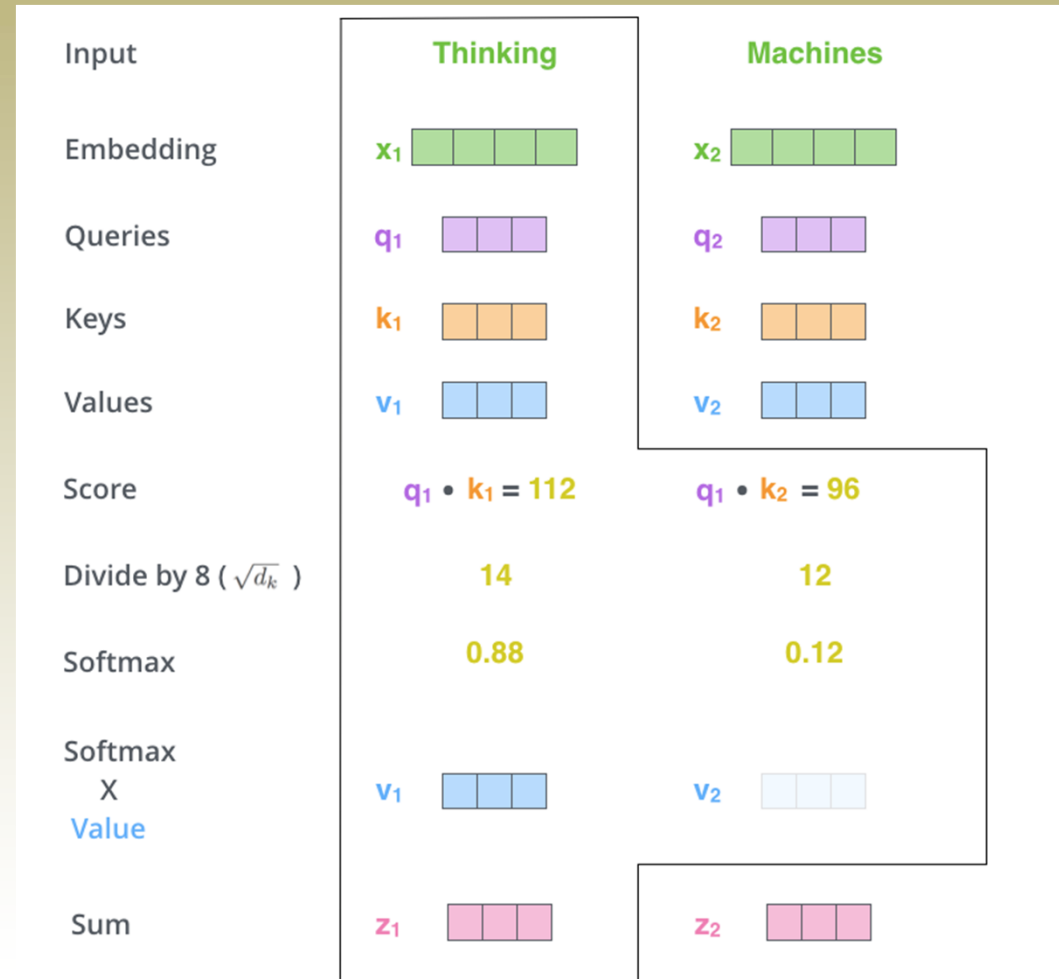

Matrix calculation of self-attention

- The first step is to calculate the Query, Key, and Value matrices
- We do that by packing our embeddings into a matrix X , and multiplying it by the weight matrices we've trained (W^Q , W^K , W^V).

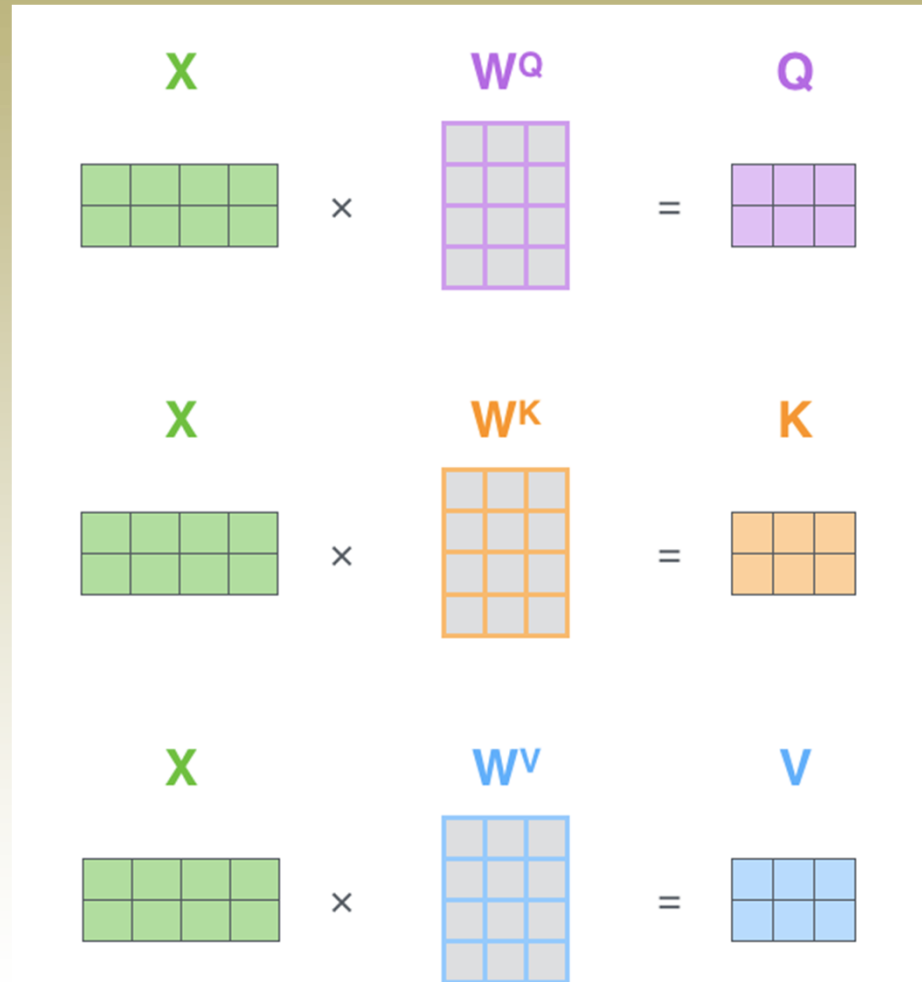

Every row in the X matrix corresponds to a word in the input sentence. We again see the difference in size of the embedding vector (512, or 4 boxes in the figure), and the q/k/v vectors (64, or 3 boxes in the figure)



Matrix calculation of self-attention

- Finally, since we're dealing with matrices, we can condense steps two through six in one formula to calculate the outputs of the self-attention layer

$$\text{softmax} \left(\frac{\begin{matrix} \text{Q} \\ \begin{matrix} \square & \square & \square \\ \square & \square & \square \end{matrix} \end{matrix} \times \begin{matrix} \text{K}^T \\ \begin{matrix} \square & \square \\ \square & \square \\ \square & \square \end{matrix} \end{matrix}}{\sqrt{d_k}} \right) \begin{matrix} \text{V} \\ \begin{matrix} \square & \square & \square \\ \square & \square & \square \end{matrix} \end{matrix}$$
$$= \begin{matrix} \text{Z} \\ \begin{matrix} \square & \square & \square \\ \square & \square & \square \end{matrix} \end{matrix}$$

The self-attention calculation in matrix form



Multi-headed attention

- We can refine the self-attention layer by adding a mechanism called “multi-headed” attention. This improves the performance of the attention layer in two ways:
 - It expands the model’s ability to focus on different positions. Yes, in the example above, z_1 contains a little bit of every other encoding, but it could be dominated by the actual word itself. If we’re translating a sentence like “The animal didn’t cross the street because it was too tired”, it would be useful to know which word “it” refers to.
 - It gives the attention layer multiple “representation subspaces”. As we’ll see next, with multi-headed attention we have not only one, but multiple sets of Query/Key/Value weight matrices (the Transformer uses eight attention heads, so we end up with eight sets for each encoder/decoder). Each of these sets is randomly initialized. Then, after training, each set is used to project the input embeddings (or vectors from lower encoders/decoders) into a different representation subspace.

Multi-headed attention

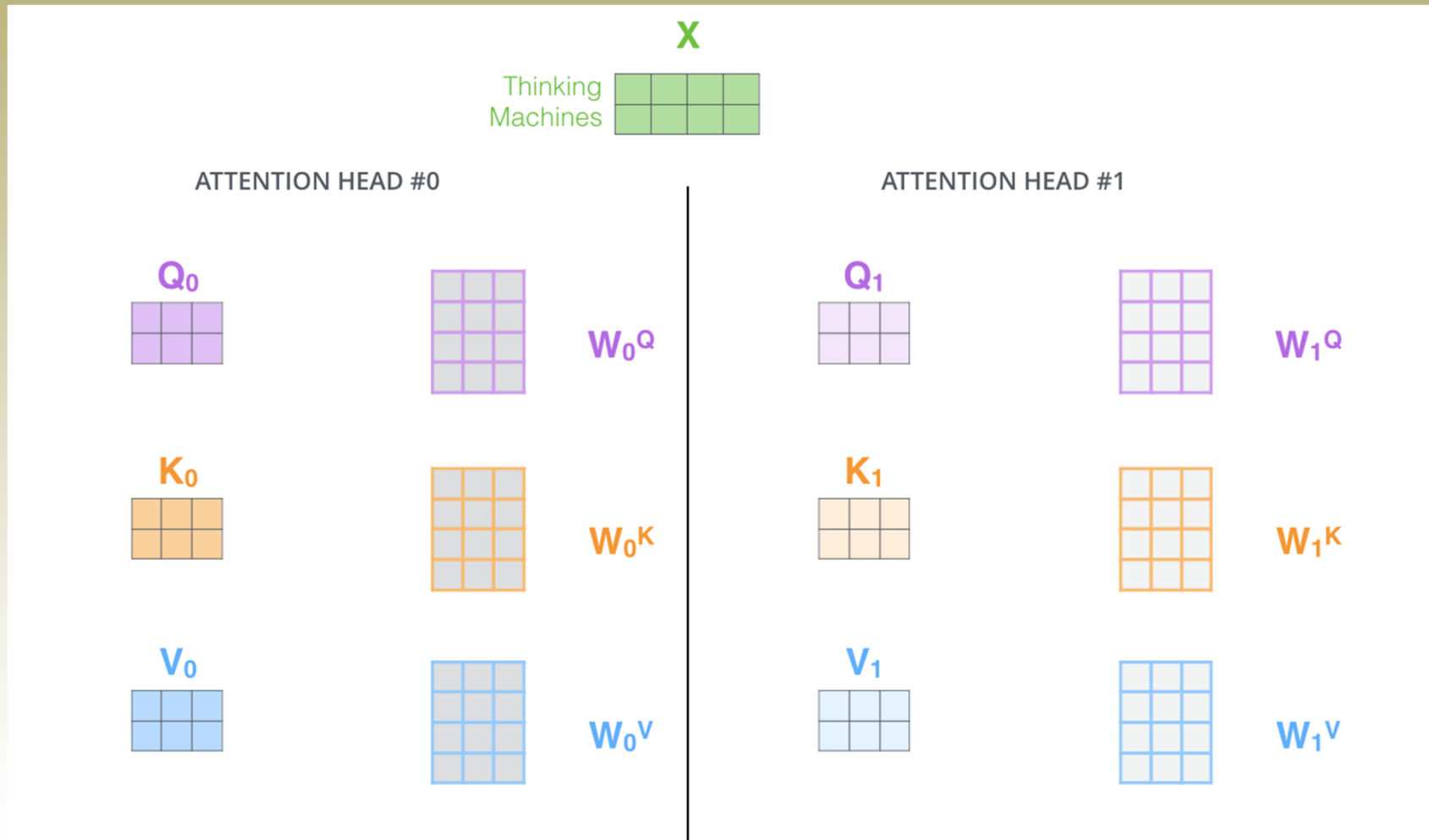

With multi-headed attention, we maintain separate Q/K/V weight matrices for each head resulting in different Q/K/V matrices. As we did before, we multiply X by the $WQ/WK/WV$ matrices to produce Q/K/V matrices.



Multi-headed attention

- If we do the same self-attention calculation we outlined above, just eight different times with different weight matrices, we end up with eight different Z matrices

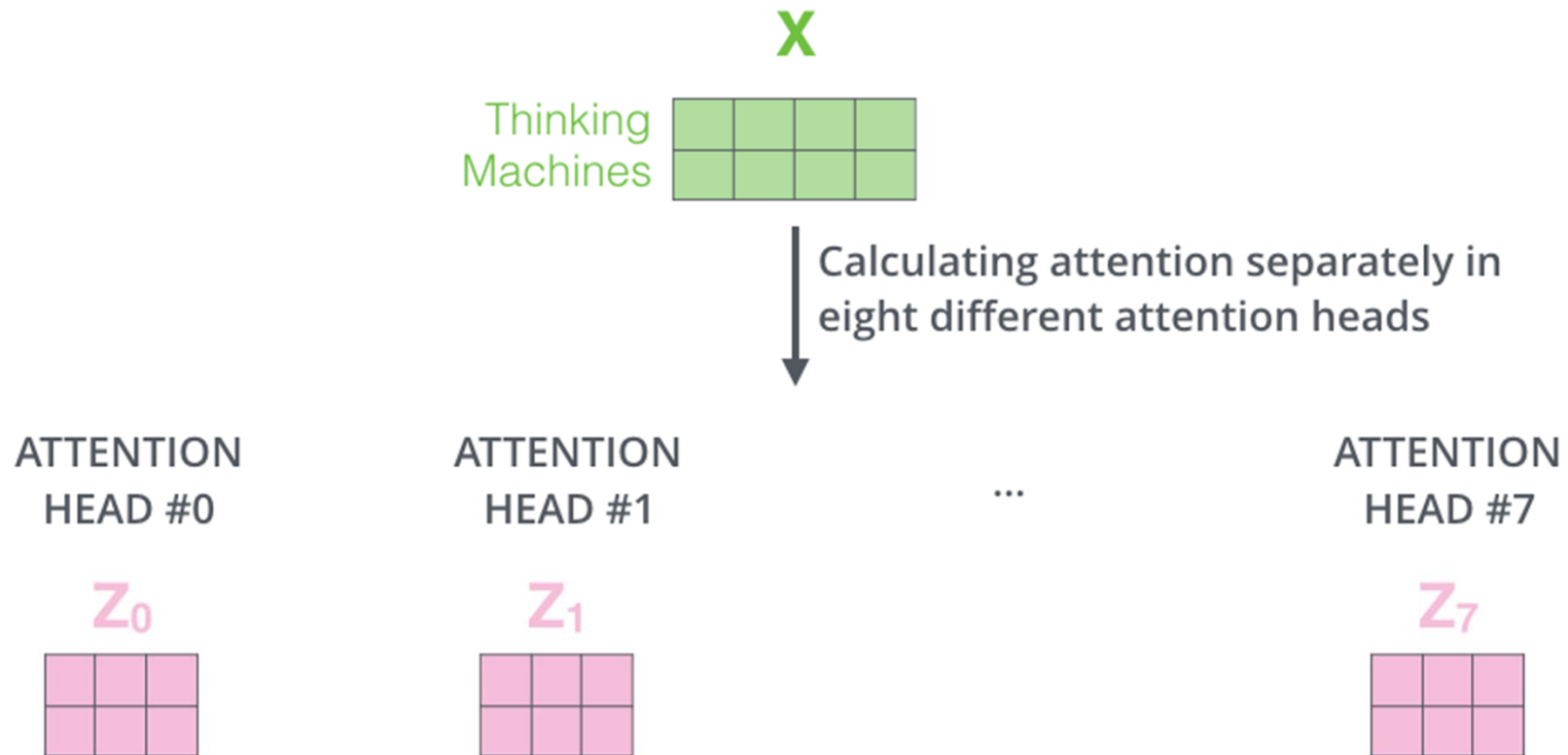



Multi-headed attention

- This leaves us with a bit of a challenge. The feed-forward layer is not expecting eight matrices – it's expecting a single matrix (a vector for each word). So we need a way to condense these eight down into a single matrix
- How do we do that? We concat the matrices then multiply them by an additional weights matrix W^O

1) Concatenate all the attention heads



2) Multiply with a weight matrix W^O that was trained jointly with the model

x

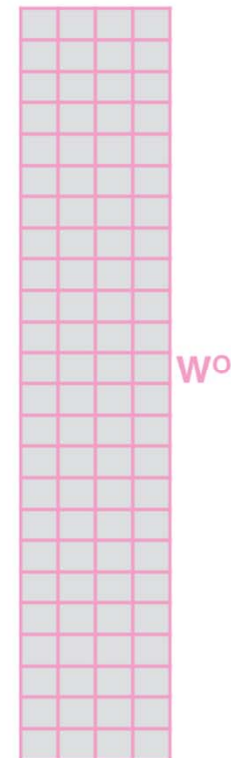

3) The result would be the Z matrix that captures information from all the attention heads. We can send this forward to the FFNN

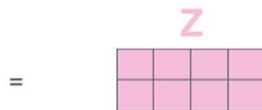



Multi-headed attention

- That's all there is to multi-headed self-attention. Let's put them all in one visual so we can look at them in one place

1) This is our input sentence*

Thinking
Machines

2) We embed each word*

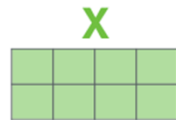

3) Split into 8 heads. We multiply X or R with weight matrices

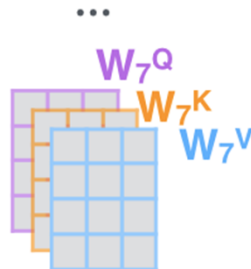
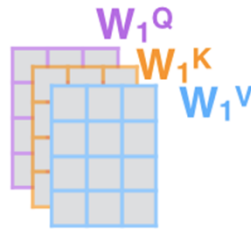
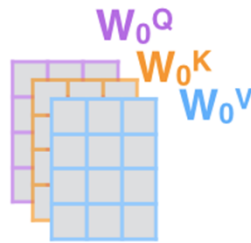

4) Calculate attention using the resulting $Q/K/V$ matrices

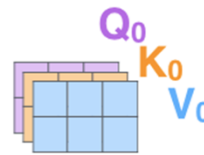

5) Concatenate the resulting Z matrices, then multiply with weight matrix W^O to produce the output of the layer

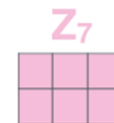
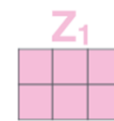
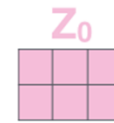

* In all encoders other than #0, we don't need embedding. We start directly with the output of the encoder right below this one



Multi-headed attention

- Now that we have touched upon attention heads, let's revisit our example from before to see where the different attention heads are focusing as we encode the word "it" in our example sentence:

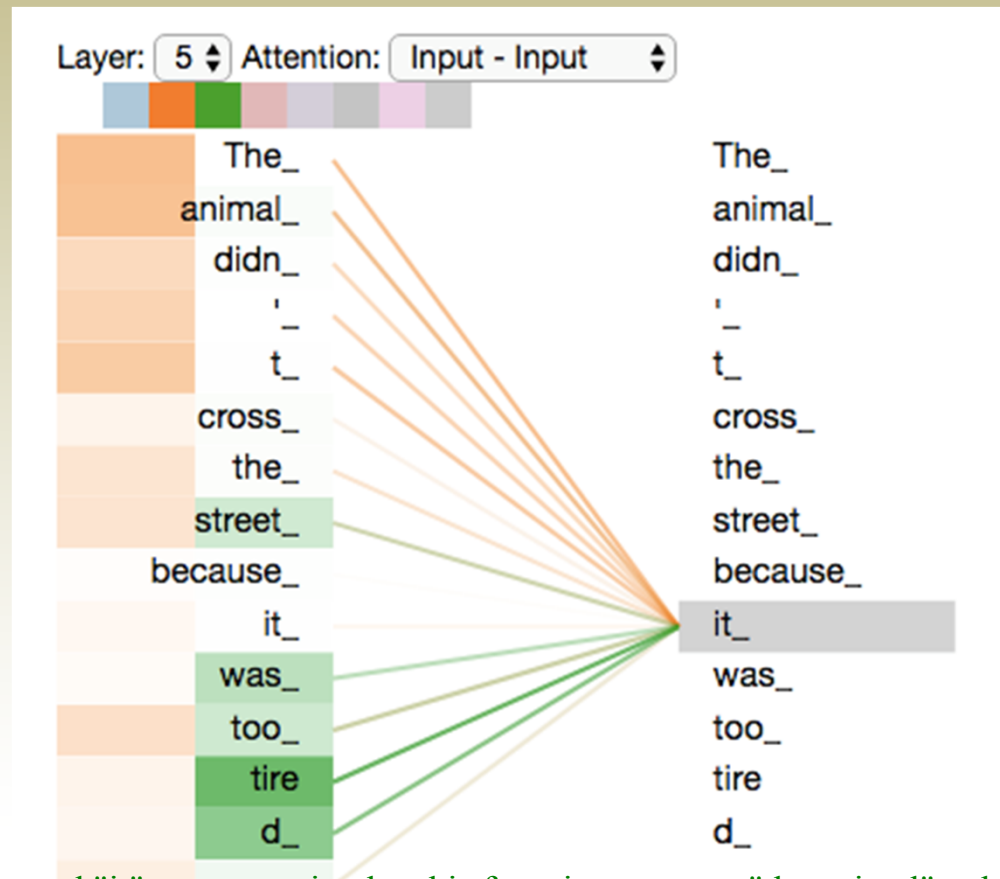

As we encode the word "it", one attention head is focusing most on "the animal", while another is focusing on "tired" -- in a sense, the model's representation of the word "it" bakes in some of the representation of both "animal" and "tired".



Multi-headed attention

- If we add all the attention heads to the picture, however, things can be harder to interpret:

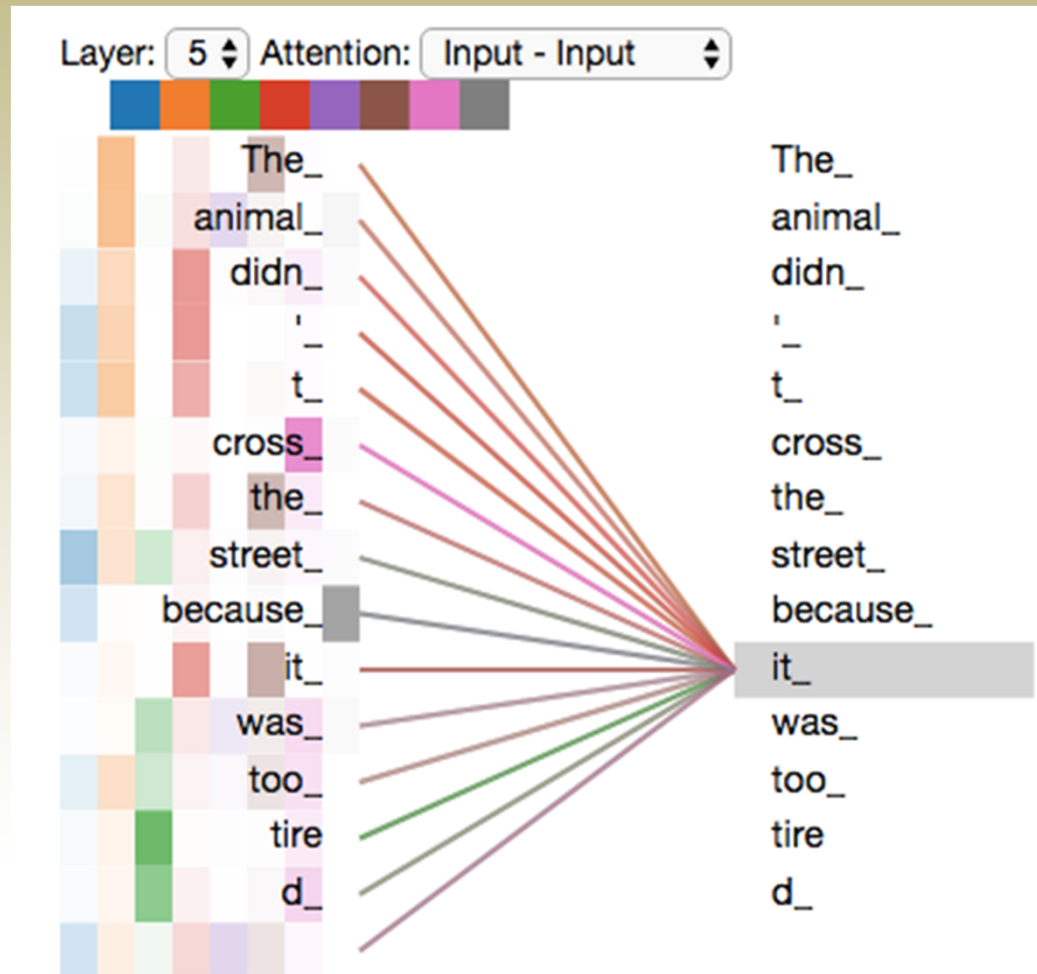



Representing The Order of The Sequence Using Positional Encoding

- One thing that's missing from the model as we have described it so far is a way to account for the order of the words in the input sequence
- To address this, the transformer adds a vector to each input embedding. These vectors follow a specific pattern that the model learns, which helps it determine the position of each word, or the distance between different words in the sequence. The intuition here is that adding these values to the embeddings provides meaningful distances between the embedding vectors once they're projected into Q/K/V vectors and during dot-product attention



Representing The Order of The Sequence Using Positional Encoding

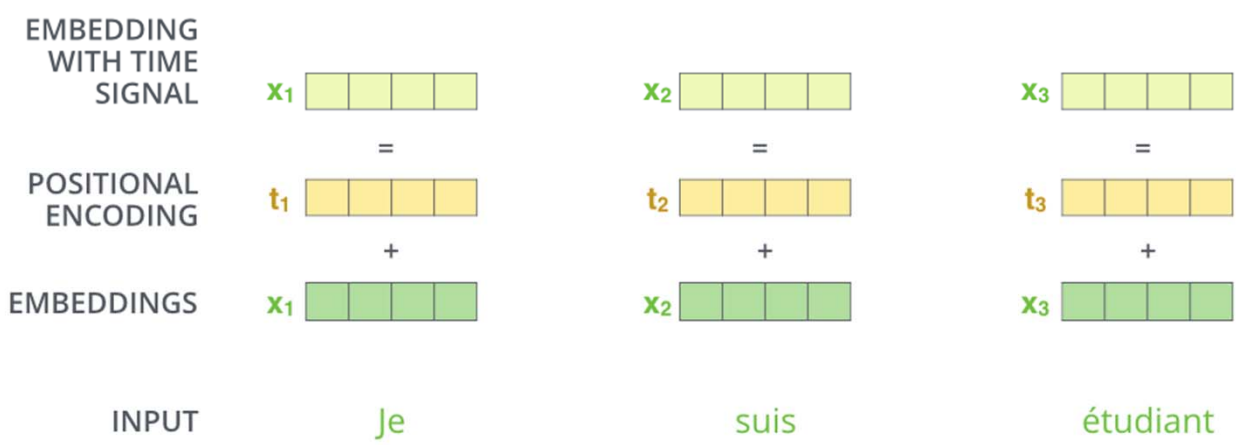
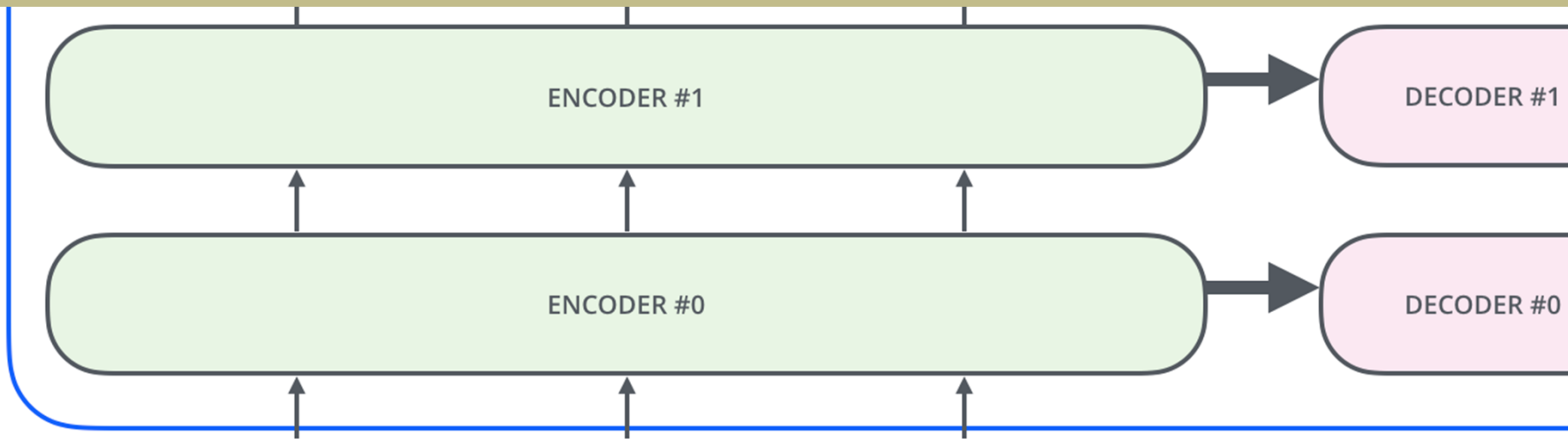



Representing The Order of The Sequence Using Positional Encoding

- If we assumed the embedding has a dimensionality of 4, the actual positional encodings would look like this:

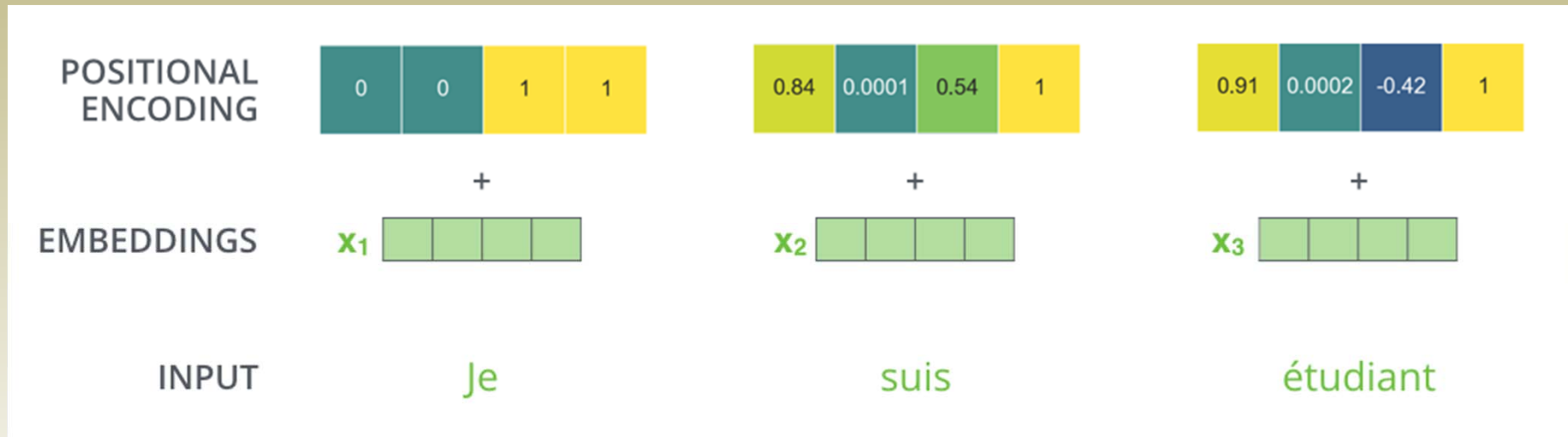

- The formula for positional encoding is described in the NIPS'2017 paper (section 3.5).
- This is not the only possible method for positional encoding. It, however, gives the advantage of being able to scale to unseen lengths of sequences (e.g. if our trained model is asked to translate a sentence longer than any of those in our training set)



The residuals

- A detail in the architecture of the encoder that we need to mention, is that each sub-layer (self-attention, ffn) in each encoder has a residual connection around it, and is followed by a layer-normalization step

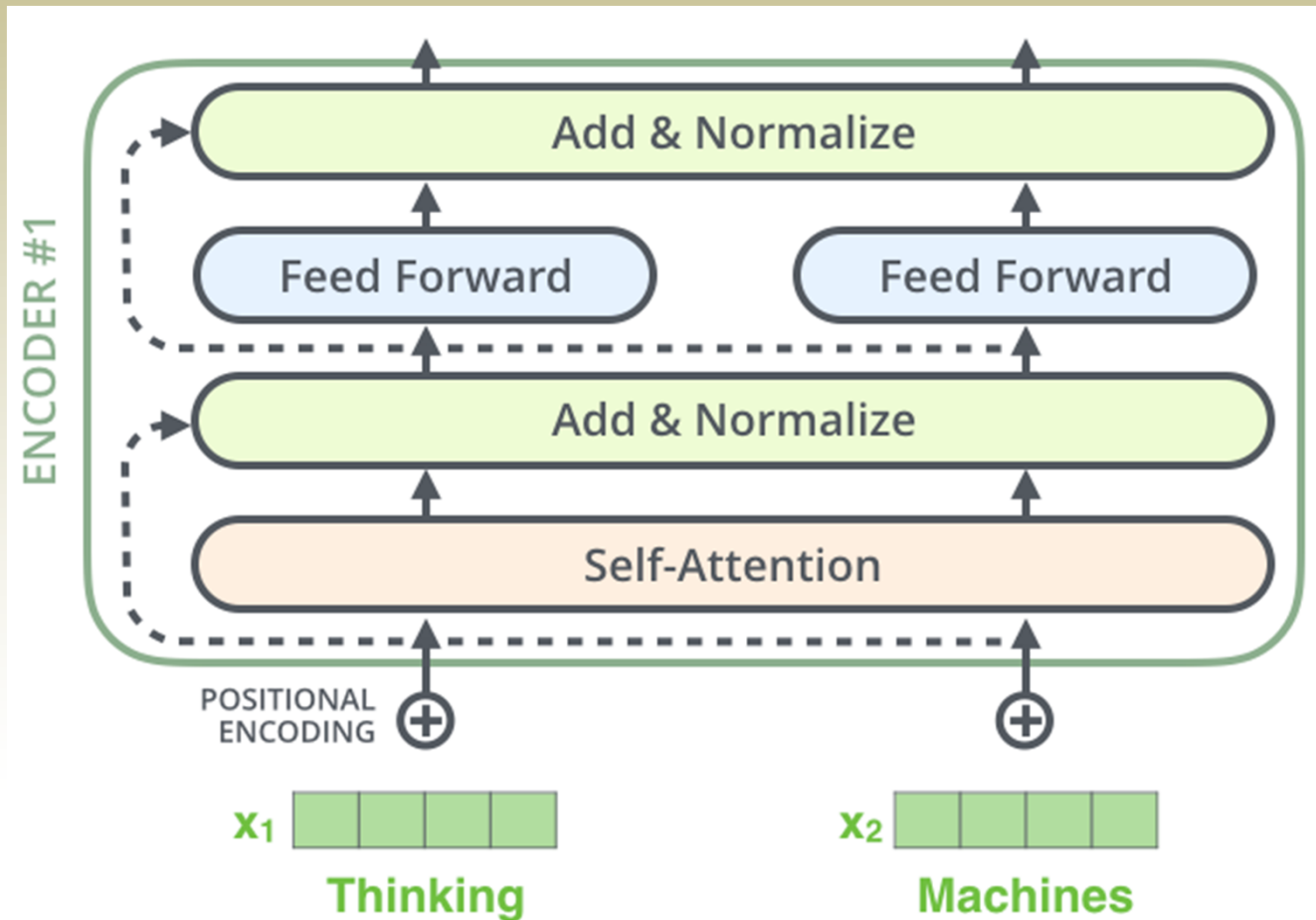



The residuals

- If we're to visualize the vectors and the layer-norm operation associated with self attention, it would look like this:

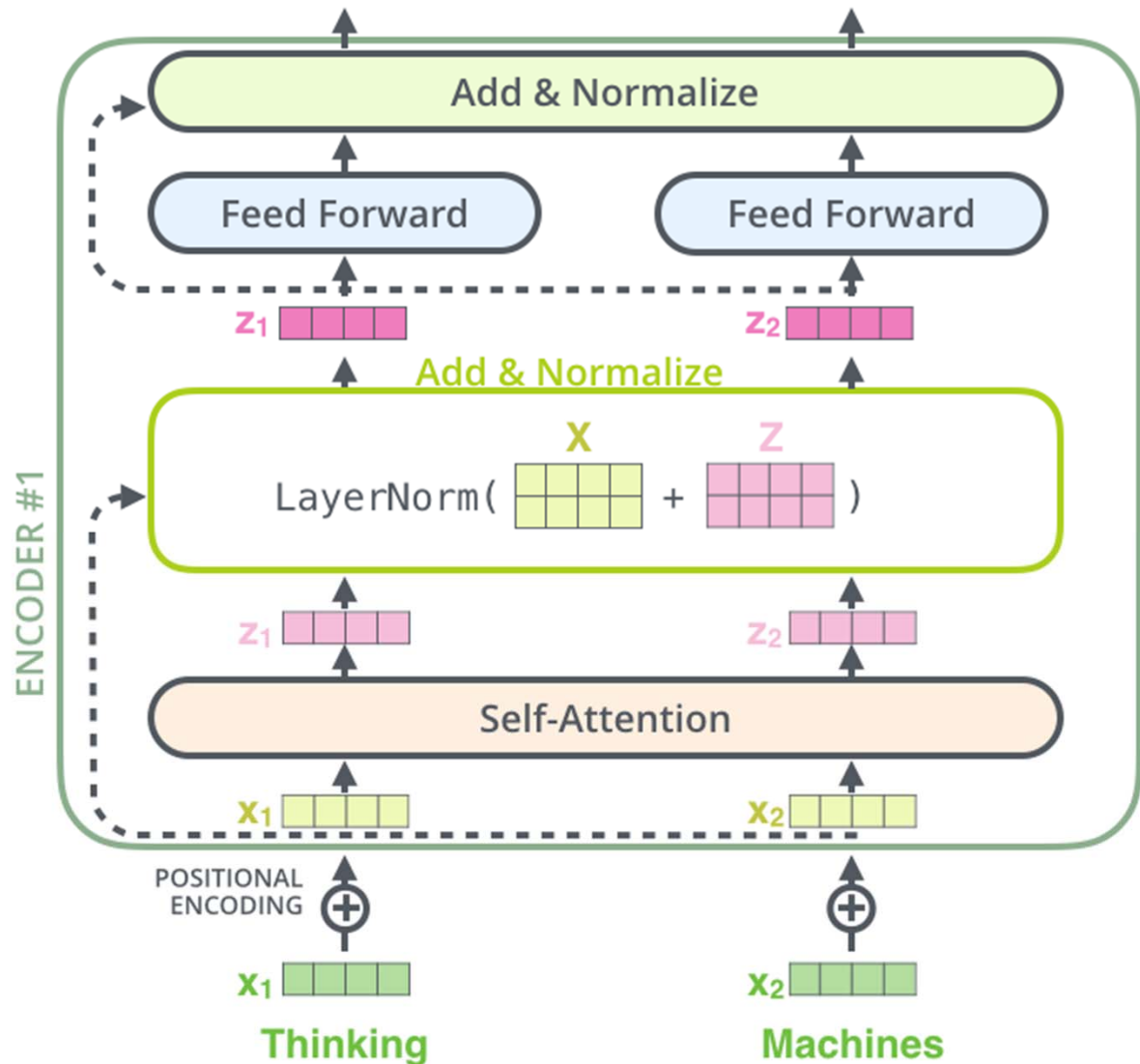



The residuals

- This goes for the sub-layers of the decoder as well. If we're to think of a Transformer of 2 stacked encoders and decoders, it would look like this

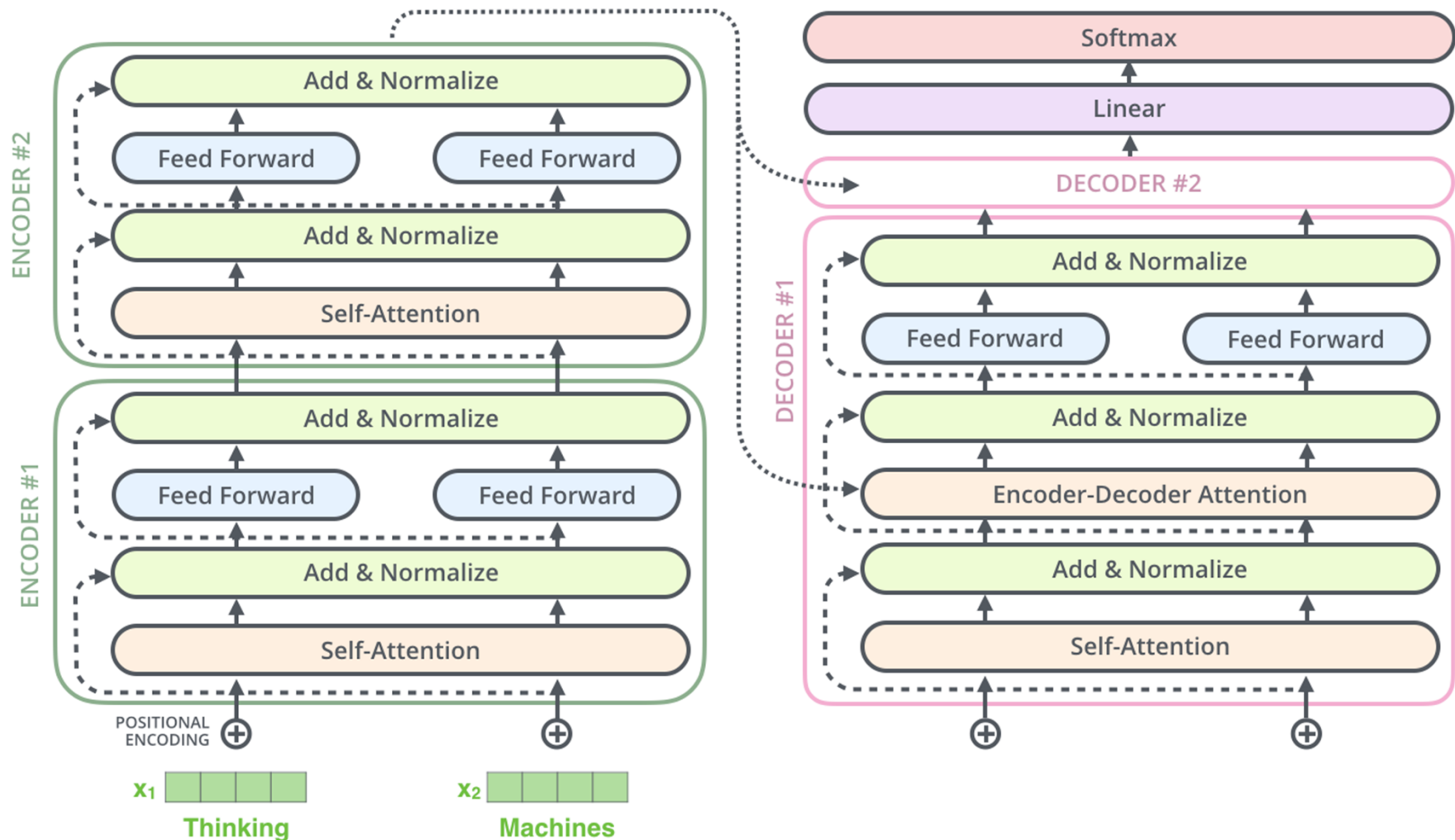



The Decoder side

- The encoder starts by processing the input sequence. The output of the top encoder is then transformed into a set of attention vectors K and V . These are to be used by each decoder in its “encoder-decoder attention” layer which helps the decoder focus on appropriate places in the input sequence:

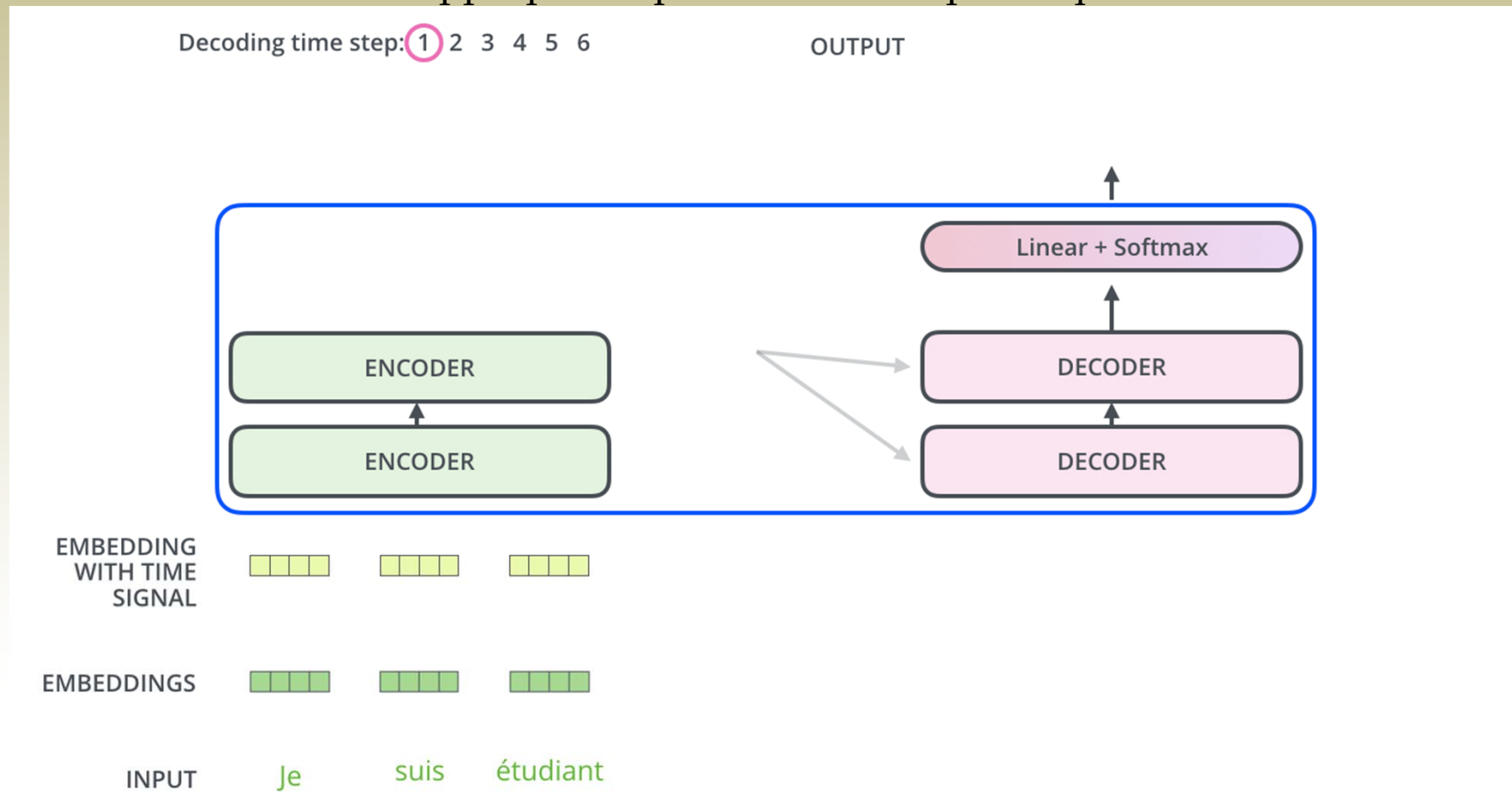



The Decoder side

- The following steps repeat the process until a special symbol is reached indicating the transformer decoder has completed its output. The output of each step is fed to the bottom decoder in the next time step, and the decoders bubble up their decoding results just like the encoders did. And just like we did with the encoder inputs, we embed and add positional encoding to those decoder inputs to indicate the position of each word

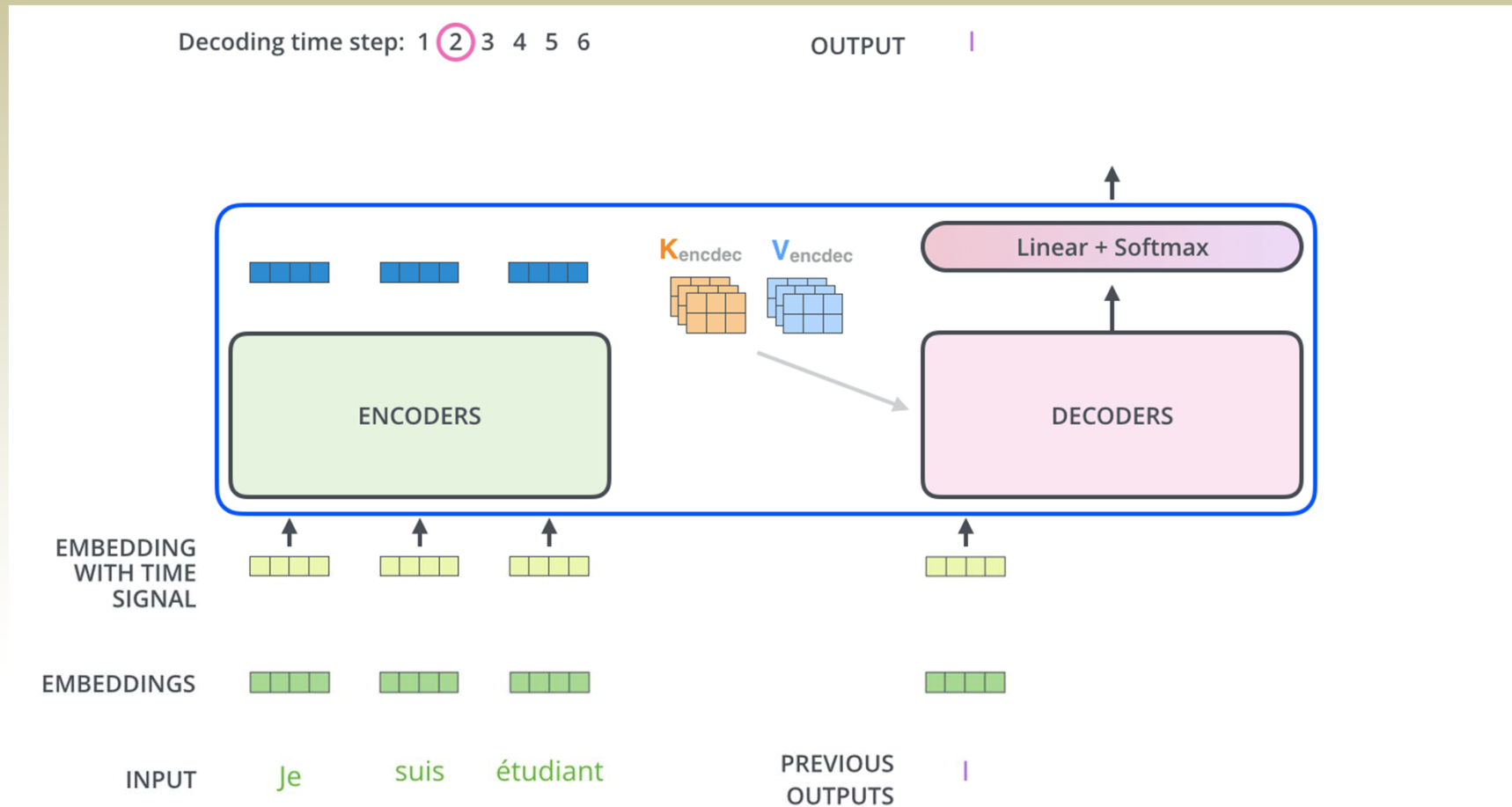



The Decoder side

- The self attention layers in the decoder operate in a slightly different way than the one in the encoder:
 - In the decoder, the self-attention layer is only allowed to attend to earlier positions in the output sequence. This is done by masking future positions (setting them to $-\infty$) before the softmax step in the self-attention calculation.
 - The “Encoder-Decoder Attention” layer works just like multiheaded self-attention, except it creates its Queries matrix from the layer below it, and takes the Keys and Values matrix from the output of the encoder stack.



The final linear and softmax layer

- The decoder stack outputs a vector of floats. How do we turn that into a word? That's the job of the final Linear layer which is followed by a Softmax Layer
- The Linear layer is a simple fully connected neural network that projects the vector produced by the stack of decoders, into a much, much larger vector called a logits vector
- Let's assume that our model knows 10,000 unique English words (our model's "output vocabulary") that it's learned from its training dataset. This would make the logits vector 10,000 cells wide – each cell corresponding to the score of a unique word. That is how we interpret the output of the model followed by the Linear layer
- The softmax layer then turns those scores into probabilities (all positive, all add up to 1.0). The cell with the highest probability is chosen, and the word associated with it is produced as the output for this time step

The final linear and softmax layer

Which word in our vocabulary is associated with this index?

Get the index of the cell with the highest value (argmax)

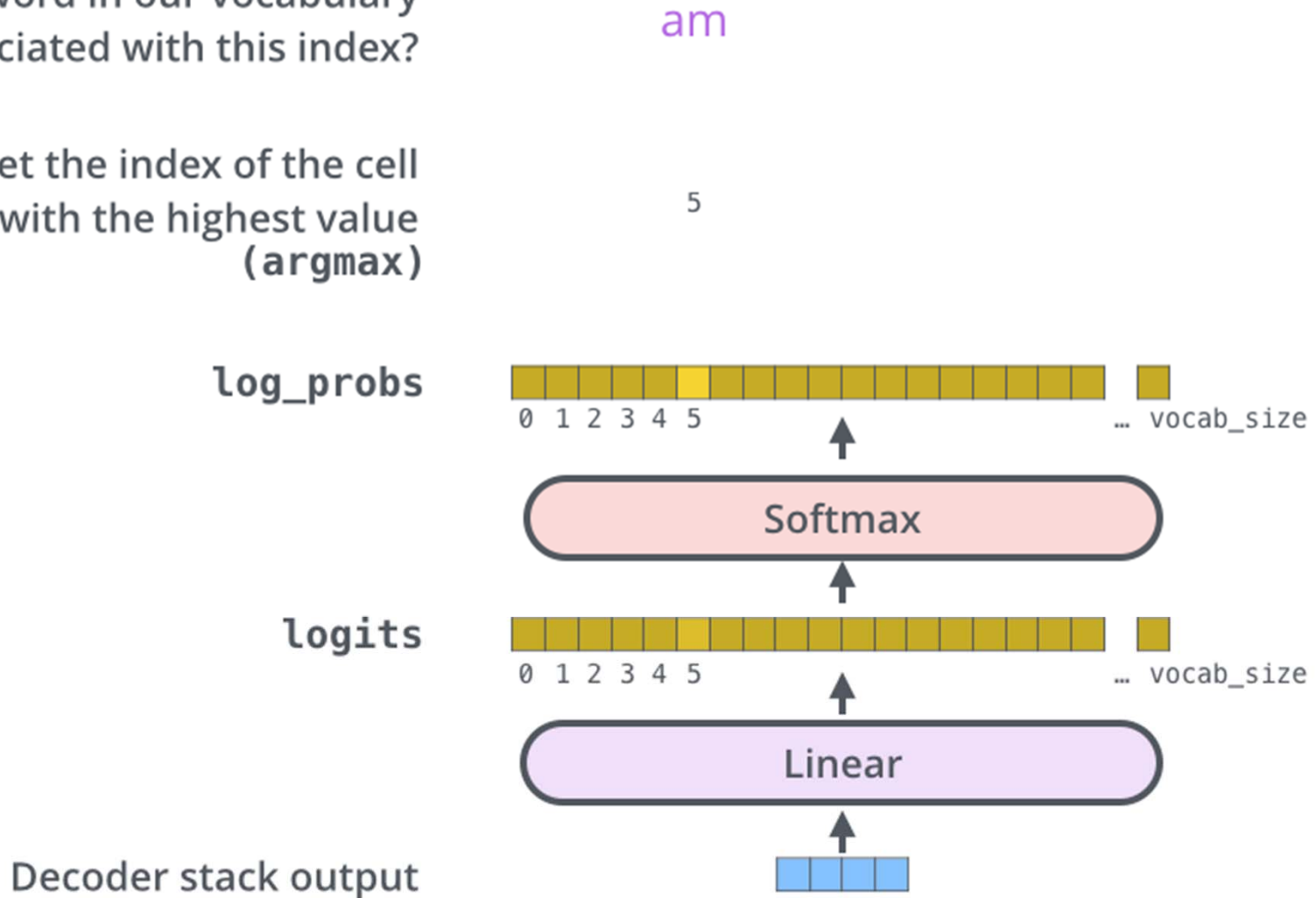



Training

- Now that we've covered the entire forward-pass process through a trained Transformer, it would be useful to glance at the intuition of training the model
- During training, an untrained model would go through the exact same forward pass. But since we are training it on a labeled training dataset, we can compare its output with the actual correct output
- To visualize this, let's assume our output vocabulary only contains six words ("a", "am", "i", "thanks", "student", and "<eos>" (short for 'end of sentence'))

Output Vocabulary

WORD	a	am	i	thanks	student	<eos>
INDEX	0	1	2	3	4	5



Training

- Once we define our output vocabulary, we can use a vector of the same width to indicate each word in our vocabulary. This also known as one-hot encoding. So for example, we can indicate the word “am” using the following vector:

Output Vocabulary

WORD	a	am	I	thanks	student	<eos>
INDEX	0	1	2	3	4	5

One-hot encoding of the word “am”

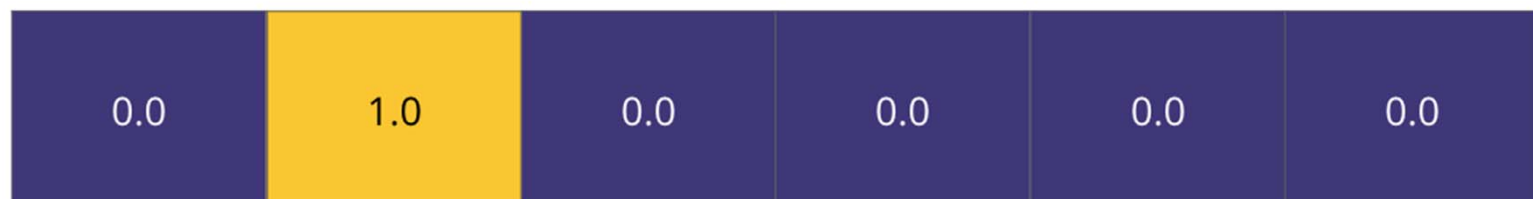



The Loss function

- Say we are training our model. Say it's our first step in the training phase, and we're training it on a simple example – translating “merci” into “thanks”.
- What this means, is that we want the output to be a probability distribution indicating the word “thanks”. But since this model is not yet trained, that's unlikely to happen just yet.

Since the model's parameters (weights) are all initialized randomly, the (untrained) model produces a probability distribution with arbitrary values for each cell/word. We can compare it with the actual output, then tweak all the model's weights using backpropagation to make the output closer to the desired output.

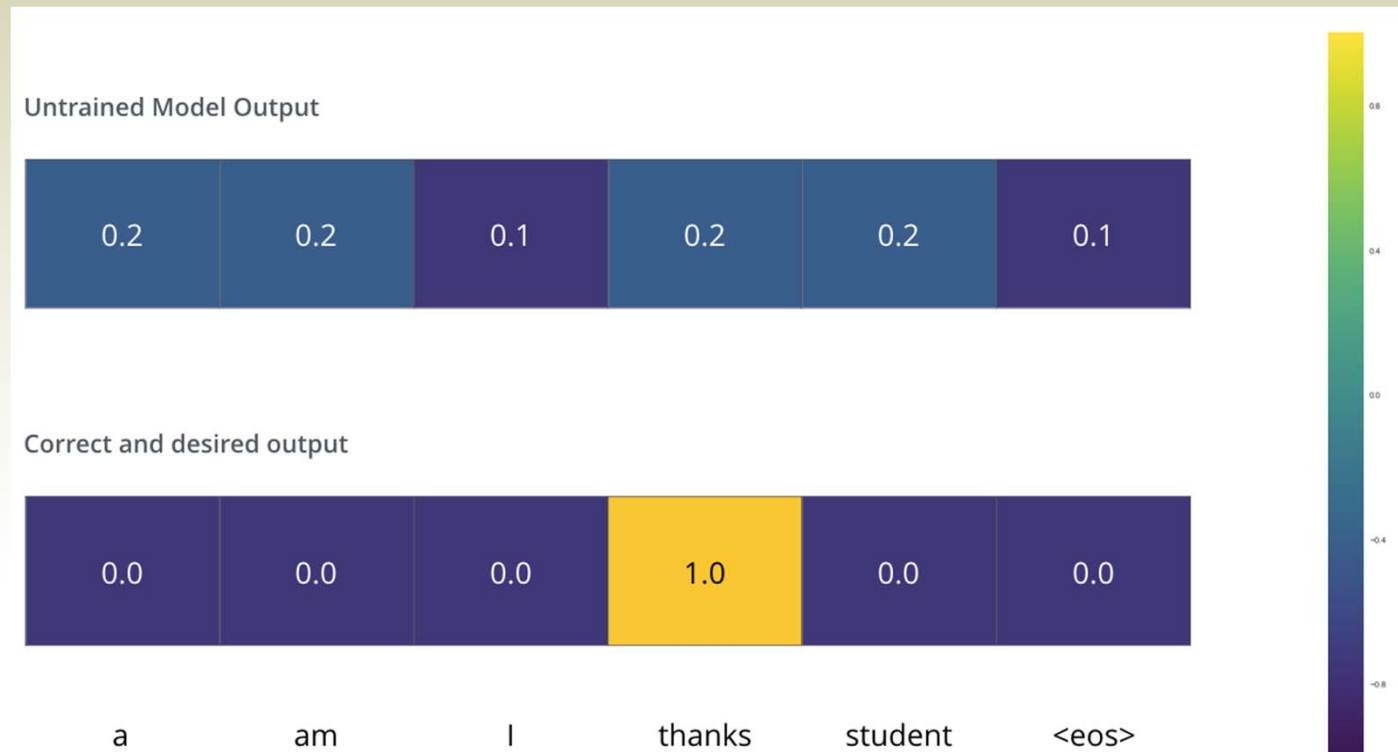



The Loss function

- How do you compare two probability distributions? We simply subtract one from the other. For more details, look at *cross-entropy* and *Kullback–Leibler divergence*.
- But note that this is an oversimplified example. More realistically, we'll use a sentence longer than one word. For example – input: “je suis étudiant” and expected output: “i am a student”. What this really means, is that we want our model to successively output probability distributions where:
 - Each probability distribution is represented by a vector of width `vocab_size` (6 in our toy example, but more realistically a number like 30,000 or 50,000)
 - The first probability distribution has the highest probability at the cell associated with the word “i”
 - The second probability distribution has the highest probability at the cell associated with the word “am”
 - And so on, until the fifth output distribution indicates ‘<end of sentence>’ symbol, which also has a cell associated with it from the 10,000 element vocabulary



The Loss function

Target Model Outputs

Output Vocabulary: a am I thanks student <eos>

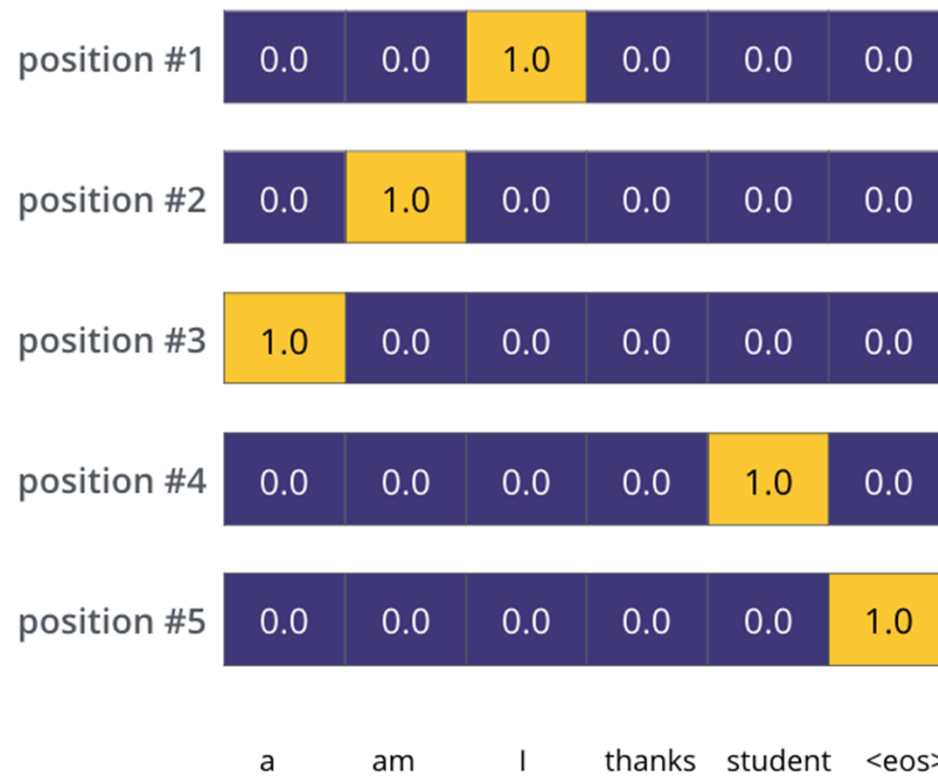

The targeted probability distributions we'll train our model against in the training example for one sample sentence



The Loss function

- After training the model for enough time on a large enough dataset, we would hope the produced probability distributions would look like this:

Hopefully upon training, the model would output the right translation we expect. Of course it's no real indication if this phrase was part of the training dataset (see: cross validation). Notice that every position gets a little bit of probability even if it's unlikely to be the output of that time step -- that's a very useful property of softmax which helps the training process.

Trained Model Outputs

Output Vocabulary: a am I thanks student <eos>

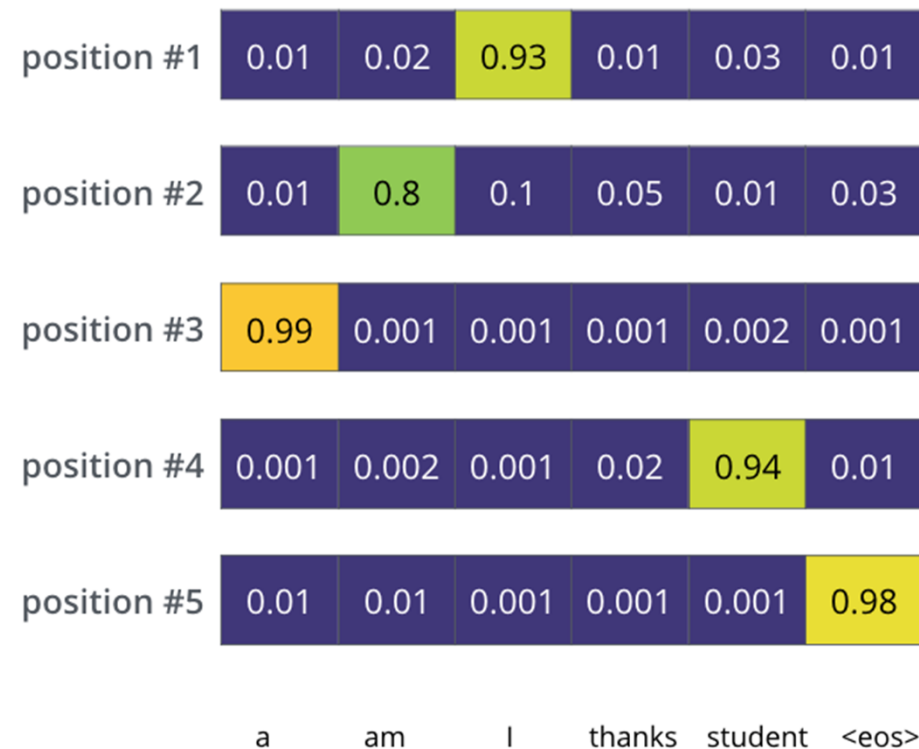



The Loss Function

- Now, because the model produces the outputs one at a time, we can assume that the model is selecting the word with the highest probability from that probability distribution and throwing away the rest
- That's one way to do it (called **greedy decoding**)
- Another way to do it would be to hold on to, say, the top two words (say, 'I' and 'a' for example), then in the next step, run the model twice: once assuming the first output position was the word 'I', and another time assuming the first output position was the word 'a', and whichever version produced less error considering both positions #1 and #2 is kept
 - We repeat this for positions #2 and #3...etc. This method is called "**beam search**", where in our example, beam_size was two (meaning that at all times, two partial hypotheses (unfinished translations) are kept in memory), and top_beams is also two (meaning we'll return two translations). These are both hyperparameters
- THE END. Read the *Attention Is All You Need* paper which appeared in **NIPS'17**