

**INTERNATIONAL ORGANISATION FOR STANDARDISATION  
ORGANISATION INTERNATIONALE DE NORMALISATION**

**ISO/IEC JTC1/SC29/WG11**

**CODING OF MOVING PICTURES AND ASSOCIATED AUDIO**

**ISO/IEC JTC1/SC29/WG11 NO803**

11 / November / 1994

---

**Information Technology -**

**Generic Coding of Moving Pictures and Associated Audio:**

**Audio**

---

**ISO/IEC 13818-3**

---

# International Standard

---

<b>Contents</b> .....	Page
Foreword .....	iii
Introduction.....	vi
0.1 Extension of ISO/IEC 11172-3 Audio Coding to Lower Sampling Frequencies .....	vi
0.2 Low bitrate coding of multichannel audio.....	vi
Section 1: General.....	1
1.1 Scope.....	1
1.2 Normative References.....	1
Section 2: Technical elements.....	2
2.1 Definitions.....	2
2. Symbols and abbreviations .....	9
2.3 Method of describing bit stream syntax .....	12
2.4 Requirements for Extension of ISO/IEC 11172-3 Audio Coding to Lower Sampling Frequencies.....	14
2.5 Requirements for low bitrate coding of multichannel audio .....	20
 Annexes	
 A. Diagrams .....	61
B. Tables .....	63
C. The encoding process .....	68
D. Psychoacoustic models.....	80
E. List of patent holders .....	108

ISO/IEC Copyright Office • Case Postale 56 • CH1211 Genève 20 • Switzerland

Printed in Switzerland.

**Foreword**

## Introduction

This Recommendation | International Standard was prepared by SC29/WG11, also known as MPEG (Moving Pictures Expert Group). MPEG was formed in 1988 to establish a standard for the coded representation of moving pictures and associated audio stored on digital storage media.

This Recommendation | International Standard is published in three parts. Part 1 - systems - specifies the system coding layer of the standard. It defines a multiplexed structure for combining audio and video data and means of representing the timing information needed to replay synchronised sequences in real-time. Part 2 - video - specifies the coded representation of video data and the decoding process required to reconstruct pictures. Part 3 - audio - specifies the coded representation of audio data and the decoding process required to decode audio signals.

### 0.1 Extension of ISO/IEC 11172-3 Audio Coding to Lower Sampling Frequencies

In order to achieve better audio quality at very low bit rates (<64 kbit/s per audio channel), in particular if compared with CCITT Standard G-722 performance, three additional sampling frequencies are provided for ISO/IEC 11172-3 layers I, II and III. The additional sampling frequencies are 16 kHz, 22,05 kHz and 24 kHz. This allows corresponding audio bandwidths of approximately 7,5 kHz, 10,3 kHz and 11,25 kHz. The syntax, semantics, and coding techniques of ISO/IEC 11172-3 are maintained except for a new definition of the sampling frequency field, the bitrate index field, and the bit allocation tables. These new definitions are valid if the ID bit in the ISO/IEC 11172-3 header equals zero. To obtain the best audio performance, the parameters of the psychoacoustic model used in the encoder have to be changed accordingly.

With these sampling frequencies, the duration of the audio frame corresponds to :

Layer	Sampling Frequency in kHz		
	16	22,05	24
I	24 ms	17,41.. ms	16 ms
II	72 ms	52,24.. ms	48 ms
III	36 ms	26,12.. ms	24 ms

### 0.2 Low bitrate coding of multichannel audio

#### 0.2.1 Universal multichannel audio system

A standard on low bit rate coding for mono or stereo audio signals was established by MPEG-1 Audio in ISO/IEC 11172-3. This standard is applicable for carrying of high quality digital audio signals associated with or without picture information on storage media or transmission channels with limited capacity.

The ISO/IEC 11172-3 audio coding standard can be used together with both MPEG-1 and MPEG-2 Video as long as only two-channel stereo is required. MPEG-2 Audio (ISO/IEC 13818-3) provides the extension to 3/2 multichannel audio and an optional low frequency enhancement channel (LFE).

Multichannel audio systems provide enhanced stereophonic stereo performance compared to conventional two channel audio systems. It is recognised that improved presentation performance is desirable not only for applications with accompanying picture but also for audio-only applications. A universal and compatible multichannel audio system applicable to satellite or terrestrial television broadcasting, digital audio broadcasting (terrestrial and satellite), as well as other non-broadcasting media, e.g.,

CATV Cable TV Distribution

CDAD Cable Digital Audio Distribution

ENG	Electronic News Gathering (including Satellite News Gathering)
IPC	Interpersonal Communications (video conference, videophone, etc.)
ISM	Interactive Storage Media (optical disks, etc.)
NDB	Network Database Services (via ATM, etc.)
DSM	Digital Storage Media (digital VTR, etc.)
EC	Electronic Cinema
HTT	Home Television Theatre
ISDN	Integrated Services Digital Network

seems to be very attractive to the manufacturer, producer, and consumer.

This document describes an audio subband coding system called ISO/MPEG-Audio Multichannel, which can be used to transfer high quality digital multichannel and/or multilingual audio information on storage media or transmission channels with limited capacity. One of the basic features is the backwards compatibility to ISO/IEC 11172-3 coded mono, stereo or dual channel audio programmes. It is designed for use in different applications as considered by the ISO/MPEG audio group and the specialist groups TG10/1, 10/2 and 10/3 of the ITU-R (previously CCIR).

## 0.2.2 Representation of multichannel audio

### 0.2.2.1 The 3/2-stereo plus LFE format

Regarding stereophonic presentation, specialist groups of ITU-R, SMPTE, and EBU recommend the use of an additional centre loudspeaker channel C and two surround loudspeaker channels LS and RS, augmenting the front left and right loudspeaker channels L and R. This reference audio format is referred to as "3/2-stereo" (3 front / 2 surround loudspeaker channels) and requires the transmission of five appropriately formatted audio signals.

For audio accompanying picture applications (e.g. HDTV), the three front loudspeaker channels ensure sufficient directional stability and clarity of the picture related frontal images, according to the common practice in the cinema. The dominant benefit is the "stable centre", which is guaranteed at any location of the listener and important for most of the dialogue.

Additionally, for audio-only applications, the 3/2-stereo format has been found to be an improvement over two-channel stereophony. The addition of one pair of surround loudspeaker channels allows improved realism of auditory ambience.

A low frequency enhancement channel (in this document called LFE channel) can, optionally, be added to any of these configurations. The purpose of this channel is to enable listeners to extend the low frequency content of the reproduced programme in terms of both frequency and level. In this way it is the same as the LFE channel proposed by the film industry for their digital sound systems.

The LFE channel should not be used for the entire low frequency content of the multichannel sound presentation. The LFE channel is optional at the receiver, and thus should only carry low frequency sound effects, which may have a high level. The LFE channel is not included in any dematrixing operation in the decoder. The sampling frequency of the LFE channel corresponds to the sampling frequency of the main channels, divided by a factor of 96. This provides 12 LFE samples within one audio frame. The LFE channel is capable of handling signals in the range from 15 Hz to 120 Hz.

### 0.2.2.2 Compatibility

#### Downwards compatibility.

A hierarchy of audio formats providing a lower number of loudspeaker channels and reduced presentation performance (down to 2/0-stereo or even mono) and a corresponding set of downwards mixing equations are recommended in ITU-R Recommendation 775 : "Multichannel stereophonic audio system with and without accompanying picture", November 1992. Alternative lower level audio formats which may be used in circumstances

where economic or channel capacity constraints apply, are 3/1, 3/0, 2/2, 2/1, 2/0, and 1/0. Corresponding loudspeaker arrangements are 3/2, 3/1, 3/0, 2/2, 2/1, 2/0, and 1/0.

### Backwards compatibility.

For several applications, the intention is to extend the existing 2/0-stereo sound system by transmitting additional audio channels (centre, surround) without making use of simulcast operation. This provision of backwards compatibility with existing receivers implies the use of compatibility matrices: the decoder of the previous generation must reproduce the two conventional basic stereo signals  $L_0/R_0$ , and the multichannel decoder produces the complete 3/2-stereo presentation  $L/C/R/LS/RS$  from the basic stereo signal and the extension signals.

It is recognised that backward compatibility may not be required for all applications of MPEG-2 Audio. Therefore, nonbackward compatible (NBC) audio coding systems free of the constraints of backward compatibility are being evaluated for optional use with the standard.

### 0.2.2.3 Multilingual capability

Particularly for HDTV applications, multichannel stereo performance and bilingual programmes or multilingual commentaries are required. This standard provides for alternative audio channel configurations in the five-channel sound system, for example a bilingual 2/0 stereo programme or one 2/0, 3/0 stereo sound plus accompanying services (e.g. "clean dialogue" for the hard-of-hearing, commentary for the visually impaired, multilingual commentary etc.). An important configuration is the reproduction of commentary dialogue (e.g. via centre loudspeaker) together with the common music/effect stereo downmix (examples are documentation film, sport reports).

## 0.2.3 Basic Parameters of the Multichannel Audio Coding System

The transmission of the five audio signals of a 3/2 sound system requires five transmission channels (although, in the context of bitrate reduced signals, these are not necessarily independent). In order that two of the transmitted signals can provide a stereo service on their own, the source sound signals are generally combined in a linear matrix prior to encoding. These combined signals (and their transmission channels) are identified by the notation T0, T1, T2, T3 and T4.

### 0.2.3.1 Compatibility with ISO/IEC 11172-3

Backwards and forwards compatibility with an ISO/IEC 11172-3 decoder is provided.

For a multichannel audio bit stream, backwards compatibility means, that an ISO/IEC 11172-3 audio decoder properly decodes the basic stereo information. The basic stereo information consists of a left and right channel that constitute an appropriate downmix of the audio information in all channels, or, optionally, the basic stereo information may consist only of the left and right channel of the multichannel audio configuration. Appropriate downmix equations are given by equation pairs (1) and (2), (3) and (4), and (5) and (6).

$$L_0 = L + x * C + y * LS \quad (1)$$

$$R_0 = R + x * C + z * RS \quad (2)$$

or

$$L_0 = L \quad (3)$$

$$R_0 = R \quad (4)$$

or

$$L_0 = L + x * C - y * jS \quad (5)$$

$$R_0 = R + x * C + y * jS \quad (6)$$



where  $jS$  is derived from LS and RS by calculation of the mono component, bandwidth limitation to the range 100-7000 Hz, half Dolby<sup>®1</sup> B-type encoding, and 90 degrees phase shifting (Prologic<sup>®1</sup> surround matrixing). Compatibility with existing surround sound decoders by use of equations (5) and (6) has not been verified at the time of printing of this Recommendation | International Standard.

Forwards compatibility means that an MPEG 2 multichannel audio decoder is able to decode properly an ISO/IEC 11172-3 audio bit stream.

The following combinations are possible:

Basic Lo, Ro Stereo	Multichannel Extension
Layer II	Layer II mc
Layer III	Layer III mc
Layer I	Layer II mc

This document describes the combinations of the basic Lo, Ro stereo of Layer I, II and III and the multichannel extension of Layer II mc and Layer III mc.

The ISO/MPEG-Audio Multichannel system provides full compatibility with the ISO Standard 11172-3. This compatibility is realised by coding the basic stereo information in conformance with ISO/IEC 11172-3 and exploiting the ancillary data field of the ISO/IEC 11172-3 audio frame and an optional extension bit stream for the multichannel extension.

The complete ISO/IEC 11172-3 frame incorporates four different types of information:

- Header information within the first 32 bits of the ISO/IEC 11172-3 audio frame.
- Cyclic Redundancy Check (CRC), consisting of 16 bits, just after the header information (optional).
- Audio data, for Layer II consisting of bit allocation (BAL), scalefactor select information (SCFSI), scalefactors (SCF), and the subband samples.
- Ancillary data. Due to the large number of different applications which will use the ISO/IEC 11172-3 Standard, the length and usage of this field are not specified.

The variable length of the ancillary data field enables packing the complete extension information of the channels T2/T3/T4 into the first part of the ancillary data field. If the MC encoder does not use all of the ancillary data field for the multichannel extension information, the remaining part of the field can be used for other ancillary data.

The bit rate required for the multichannel extension information may vary on a frame by frame basis, depending on the sound signals. The overall bit rate may be increased above that provided for in ISO/IEC 11172-3 by the use of an optional extension bit stream. The maximum bit rate, including the extension bit stream, is given by the following table:

Sampling Frequency	Layer	Maximum Total Bit Rate
32 kHz	I	903 kbit/s
32 kHz	II	839 kbit/s
32 kHz	III	775 kbit/s
44.1 kHz	I	1075 kbit/s

<sup>1</sup>Dolby and Prologic are registered trademarks of Dolby Laboratories Licensing Corp.

44.1 kHz	II	1011 kbit/s
44.1 kHz	III	947 kbit/s
48 kHz	I	1130 kbit/s
48 kHz	II	1066 kbit/s
48 kHz	III	1002 kbit/s

### 0.2.3.2 Audio Input/Output Format

Sampling frequencies : 48, 44.1 or 32 kHz

Quantisation : up to 24 bits/sample PCM resolution

The following combinations of audio channels can be applied as inputs to the audio encoder:

- a) Five channels, using the 3/2 configuration  
L, C, R plus two surround channels LS, RS
- b) Five channels, using the 3/0 + 2/0 configuration  
L, C, R of first programme plus L2, R2 of second programme
- c) Four channels, using the 3/1 configuration  
L, C, R plus single surround channel S
- d) Four channels, using the 2/2 configuration  
L, R plus two surround channels LS, RS
- e) Four channels, using the 2/0 + 2/0 configuration  
L, R of first programme plus L2, R2 of second programme
- f) Three channels using the 3/0 configuration  
L, C, R without surround
- g) Three channels using the 2/1 configuration  
L, R with single surround channel S
- h) Two channels, using the 2/0 configuration  
Stereo or dual channel mode (as in ISO/IEC 11172-3)
- i) One channel, using the 1/0 configuration  
Single channel mode (as in ISO/IEC 11172-3)

The different combinations of audio input signals are encoded and transmitted within the up to five available transmission channels T0, T1, T2, T3, and T4, of which channels T0 and T1 are the two basic channels of ISO/IEC 11172-3 and convey the backwards compatible signals Lo and Ro. Transmission channels T2, T3, and T4 together form the multichannel extension information, which is compatibly transmitted within the ISO/IEC 11172-3 ancillary data field and an optional extension bit stream.

After multichannel decoding, the up to five audio channels are recovered and can then be presented in any convenient format at the choice of the listeners:

- a) Five channels, using the 3/2 configuration  
Front: Left (L) and right (R) channels plus centre channel (C)  
Surround: Left surround (LS) and right surround (RS)
- b) Four channels, using the 3/1 configuration  
Front: Left (L) and right (R) channels plus centre channel (C)  
Surround: Mono surround (S)

- c) Four channels, using the 2/2 configuration  
Front: Left (L) and right (R) channel  
Surround: Left surround (LS) and right surround (RS)
- d) Three channels, using the 2/1 configuration  
Front: Left (L) and right (R) channels  
Surround: Mono surround (S)
- e) Three channels using the 3/0 configuration  
Front: Left (L) and right (R) channel plus centre channel (C)  
Surround: No surround
- f) Two channels, using the 2/0 configuration  
Front: Left (L) and right channel (R)  
Surround: No surround
- g) One channel output, using the 1/0 configuration  
Front: Mono channel (Mo)  
Surround: No surround

A low frequency enhancement channel can, optionally, be added to any of these configurations.

Outputs may be required to provide discrete signals, or may be combined in accordance with downward mixing, or upwards conversion equations, as defined in ITU-R Recommendation 775.

### 0.2.3.3 Composite Coding Modes

#### Dynamic Transmission Channel Switching

In order to provide a better orthogonality between the two compatible signals T0 and T1, and the three additionally transmitted signals T2, T3 and T4, it is necessary to have flexibility in the choice of the channels T2, T3 and T4. ISO/IEC 13818-3 allows, independently for a number of frequency regions, the selection of a number of combinations of three out of the five signals L, C, R, LS, RS to be transmitted in T2, T3, T4.

#### Dynamic Crosstalk

According to a binaural hearing model, it is possible to determine the portion of the stereophonic signal which is irrelevant with respect to the spatial perception of the stereophonic presentation. The stereo-irrelevant signal components are not masked, but they do not contribute to the localisation of sound sources. They are ignored in the binaural processor of the human auditory system. Therefore, stereo-irrelevant components of any stereo signal (L, C, R, LS or RS) may be reproduced via any loudspeaker, or via several loudspeakers of the arrangement, without affecting the stereophonic impression. This can be done independently for a number of frequency regions.

#### Adaptive Multichannel Prediction

In order to make use of the statistical inter-channel dependencies, adaptive multichannel prediction is used for redundancy reduction. Instead of transmitting the actual signals in the transmission channels T2, T3, T4, the corresponding prediction error signals are transmitted. A predictor of up to 2nd order with delay compensation is used.

#### Phantom Coding of Centre

Due to the fact that the human auditory system uses only intensity cues of the audio signal for localisation at higher frequencies, it is possible to transmit the high frequency part of the centre channel in the front left and right channels, constituting a phantom source at the location of the centre loudspeaker.

### 0.2.3.4 Encoder and Decoder Parameters

Encoding and decoding are similar to ISO/IEC 11172-3.

## Coding modes :

3/2, 3/0 + 2/0, 3/1, 2/0 + 2/0, 3/0, 2/2, 2/1, 2/0, 1/0  
second stereo programme,  
up to 7 additional multilingual or commentary channels,  
associated services

## Subband filter transforms:

Number of subbands: 32  
Sampling frequency:  $F_s/32$   
Bandwidth of subbands:  $F_s/64$

## Additional decomposition by MDCT (Layer III only):

Frequency Resolution: 6 or 18 components per subband

## LFEC filter transform:

Number of LFECs: 1  
Sampling frequency:  $F_s/96$   
Bandwidth of LFEC: 125 Hz

Dynamic range : more than 20 bits

# Information Technology - Generic Coding of Moving Pictures and Associated Audio: Audio

---

## Section 1: General

### 1.1 Scope

This Recommendation | International Standard specifies the extension of ISO/IEC 11172-3 to lower sampling frequencies, the coded representation of multichannel and multilingual high quality audio for broadcasting, transmission and storage media, and the method for decoding of multichannel and multilingual high quality audio signals. The input of the encoder and the output of the decoder are compatible with existing PCM standards.

### 1.2 Normative References

The following ITU-T/CCITT Recommendations and International Standards contain provisions which, through reference in this text, constitute provisions of this Recommendation | International Standard. At the time of publication, the editions indicated were valid. All recommendations and Standards are subject to revision, and parties to agreements based on this Recommendation | International Standard are encouraged to investigate the possibility of applying the most recent editions of the Recommendations and Standards listed below. Members of IEC and ISO maintain registers of currently valid International Standards. The Telecommunication Standardization Bureau of the ITU maintains a list of the currently valid ITU-T/CCITT Recommendations.

ISO/IEC 11172-3:1993, Information Technology - *Coding of moving pictures and associated audio for digital storage media at up to about 1.5 Mbit/s, Part 3: Audio.*

CCIR Recommendation 775: 1992, *Multichannel stereophonic sound system with and without accompanying picture.*

Recommendations and reports of the CCIR, 1990  
XVIIth Plenary Assembly, Düsseldorf, 1990  
Volume XI - Part 1  
Broadcasting Service (Television)  
Rec. 601-1, *Encoding parameters of digital television for studios.*

CCIR Volume X and XI Part 3  
Recommendation 648: *Recording of audio signals.*

CCIR Volume X and XI Part 3  
Report 955-2: *Sound broadcasting by satellite for portable and mobile receivers, including Annex IV Summary description of Advanced Digital System II.*

IEEE Draft Standard P1180/D2: 1990, *Specification for the implementation of 8x 8 inverse discrete cosine transform.*

IEC publication 908: 1987, *CD Digital Audio System.*

## Section 2: Technical elements

### 2.1 Definitions

For the purposes of this Recommendation | International Standard, the following definitions apply. If specific to a part, this is noted in square brackets.

**2.1.1 ac coefficient [video]:** Any DCT coefficient for which the frequency in one or both dimensions is non-zero.

**2.1.2 access unit [system]:** In the case of compressed audio an access unit is an audio access unit. In the case of compressed video an access unit is the coded representation of a picture.

**2.1.3 adaptive segmentation [audio]:** A subdivision of the digital representation of an audio signal in variable segments of time.

**2.1.4 adaptive bit allocation [audio]:** The assignment of bits to subbands in a time and frequency varying fashion according to a psychoacoustic model.

**2.1.5 adaptive multichannel prediction [audio]:** A method of multichannel data reduction exploiting statistical inter-channel dependencies.

**2.1.6 adaptive noise allocation [audio]:** The assignment of coding noise to frequency bands in a time and frequency varying fashion according to a psychoacoustic model.

**2.1.7 alias [audio]:** Mirrored signal component resulting from sub-Nyquist sampling.

**2.1.8 analysis filterbank [audio]:** Filterbank in the encoder that transforms a broadband PCM audio signal into a set of subsampled subband samples.

**2.1.9 ancillary data [audio]:** part of the bit stream that might be used for transmission of ancillary data.

**2.1.10 audio access unit [audio]:** For Layers I and II, an audio access unit is defined as the smallest part of the encoded bit stream which can be decoded by itself, where decoded means "fully reconstructed sound". For Layer III, an audio access unit is part of the bit stream that is decodable with the use of previously acquired main information.

**2.1.11 audio buffer [audio]:** A buffer in the system target decoder for storage of compressed audio data.

**2.1.12 audio sequence [audio]:** A non-interrupted series of audio frames in which the following parameters are not changed:

- ID
- Layer
- Sampling Frequency
- For Layer I and II: Bitrate index

**2.1.13 backward motion vector [video]:** A motion vector that is used for motion compensation from a reference picture at a later time in display order.

**2.1.14 Bark [audio]:** Unit of critical band rate. The Bark scale is a non-linear mapping of the frequency scale over the audio range closely corresponding with the frequency selectivity of the human ear across the band.

**2.1.15 bidirectionally predictive-coded picture; B-picture [video]:** A picture that is coded using motion compensated prediction from a past and/or future reference picture.

**2.1.16 bitrate:** The rate at which the compressed bit stream is delivered from the storage medium to the input of a decoder.

**2.1.17 block companding [audio]:** Normalising of the digital representation of an audio signal within a certain time period.

**2.1.18 block [video]:** An 8-row by 8-column orthogonal block of pels.

**2.1.19 bound [audio]:** The lowest subband in which intensity stereo coding is used.

**2.1.20 byte:** Sequence of 8-bits.

**2.1.21 byte aligned:** A bit in a coded bit stream is byte-aligned if its position is a multiple of 8-bits from the first bit in the stream.

**2.1.22 centre channel [audio]:** An audio presentation channel used to stabilise the central component of the frontal stereo image.

**2.1.23 channel:** A digital medium that stores or transports a CD 13818 bit stream.

**2.1.24 channel [audio]:** A sequence of data representing an audio signal being transported.

**2.1.25 chrominance (component) [video]:** A matrix, block or single pel representing one of the two colour difference signals related to the primary colours in the manner defined in CCIR Rec 601. The symbols used for the colour difference signals are Cr and Cb.

**2.1.26 coded audio bit stream [audio]:** A coded representation of an audio signal as specified in this part of the CD.

**2.1.27 coded video bit stream [video]:** A coded representation of a series of one or more pictures as specified in this CD.

**2.1.28 coded order [video]:** The order in which the pictures are stored and decoded. This order is not necessarily the same as the display order.

**2.1.29 coded representation:** A data element as represented in its encoded form.

**2.1.30 coding parameters [video]:** The set of user-definable parameters that characterise a coded video bit stream. Bit streams are characterised by coding parameters. Decoders are characterised by the bit streams that they are capable of decoding.

**2.1.31 component [video]:** A matrix, block or single pel from one of the three matrices (luminance and two chrominance) that make up a picture.

**2.1.32 compression:** Reduction in the number of bits used to represent an item of data.

**2.1.33 constant bitrate coded video [video]:** A compressed video bit stream with a constant average bitrate.

**2.1.34 constant bitrate:** Operation where the bitrate is constant from start to finish of the compressed bit stream.

**2.1.35 constrained parameters [video]:** The values of the set of coding parameters defined in 2.4.3.2 of ISO/IEC 11172-2.

**2.1.36 constrained system parameter stream (CSPS) [system]:** An ISO/IEC 11172 multiplexed stream for which the constraints defined in 2.4.6 of ISO/IEC 11172-1 apply.

**2.1.37 CRC:** Cyclic redundancy check.

**2.1.38 critical band rate [audio]:** Psychoacoustic function of frequency. At a given audible frequency, it is proportional to the number of critical bands below that frequency. The units of the critical band rate scale are Barks.

**2.1.39 critical band [audio]:** Psychoacoustic measure in the spectral domain which corresponds to the frequency selectivity of the human ear. This selectivity is expressed in Bark.

**2.1.40 data element:** An item of data as represented before encoding and after decoding.

**2.1.41 dc-coefficient [video]:** The DCT coefficient for which the frequency is zero in both dimensions.

**2.1.42 dc-coded picture; D-picture [video]:** A picture that is coded using only information from itself. Of the DCT coefficients in the coded representation, only the dc-coefficients are present.

**2.1.43 DCT coefficient:** The amplitude of a specific cosine basis function.

**2.1.44 decoded stream:** The decoded reconstruction of a compressed bit stream.

**2.1.45 decoder input buffer [video]:** The first-in first-out (FIFO) buffer specified in the video buffering verifier.

- 2.1.46 decoder input rate [video]:** The data rate specified in the video buffering verifier and encoded in the coded video bit stream.
- 2.1.47 decoder:** An embodiment of a decoding process.
- 2.1.48 decoding (process):** The process defined in ISO/IEC 11172 that reads an input coded bit stream and produces decoded pictures or audio samples.
- 2.1.49 decoding time-stamp; DTS [system]:** A field that may be present in a packet header that indicates the time that an access unit is decoded in the system target decoder.
- 2.1.50 de-emphasis [audio]:** Filtering applied to an audio signal after storage or transmission to undo a linear distortion due to emphasis.
- 2.1.51 dequantisation [video]:** The process of rescaling the quantised DCT coefficients after their representation in the bit stream has been decoded and before they are presented to the inverse DCT.
- 2.1.52 digital storage media; DSM:** A digital storage or transmission device or system.
- 2.1.53 discrete cosine transform; DCT [video]:** Either the forward discrete cosine transform or the inverse discrete cosine transform. The DCT is an invertible, discrete orthogonal transformation. The inverse DCT is defined in annex A of ISO/IEC 11172-2.
- 2.1.54 display order [video]:** The order in which the decoded pictures should be displayed. Normally this is the same order in which they were presented at the input of the encoder.
- 2.1.55 downmix [audio]:** A matrixing of n channels to obtain less than n channels.
- 2.1.56 dual channel mode [audio]:** A mode, where two audio channels with independent programme contents (e.g. bilingual) are encoded within one bit stream. The coding process is the same as for the stereo mode.
- 2.1.57 dynamic crosstalk [audio]:** A method of multichannel data reduction in which stereo-irrelevant signal components are copied to another channel.
- 2.1.58 dynamic transmission channel switching [audio]:** A method of multichannel data reduction by allocating the most orthogonal signal components to the transmission channels.
- 2.1.59 editing:** The process by which one or more compressed bit streams are manipulated to produce a new compressed bit stream. Conforming edited bit streams must meet the requirements defined in this CD.
- 2.1.60 elementary stream [system]:** A generic term for one of the coded video, coded audio or other coded bit streams.
- 2.1.61 emphasis [audio]:** Filtering applied to an audio signal before storage or transmission to improve the signal-to-noise ratio at high frequencies.
- 2.1.62 encoder:** An embodiment of an encoding process.
- 2.1.63 encoding (process):** A process, not specified in this CD, that reads a stream of input pictures or audio samples and produces a valid coded bit stream as defined in this CD.
- 2.1.64 entropy coding:** Variable length lossless coding of the digital representation of a signal to reduce redundancy.
- 2.1.65 extension bit stream [audio]:** Information contained in an additional bit stream related to the basic audio bit stream at the system level, to support bit rates beyond those defined in ISO/IEC 11172-3. The additional bitstream contains the remainder of the multichannel and multilingual data.
- 2.1.66 fast forward playback [video]:** The process of displaying a sequence, or parts of a sequence, of pictures in display-order faster than real-time.
- 2.1.67 FFT:** Fast Fourier Transformation. A fast algorithm for performing a discrete Fourier transform (an orthogonal transform).
- 2.1.68 filterbank [audio]:** A set of band-pass filters covering the entire audio frequency range.



- 2.1.69 fixed segmentation [audio]:** A subdivision of the digital representation of an audio signal into fixed segments of time.
- 2.1.70 forbidden:** The term "forbidden" when used in the clauses defining the coded bit stream indicates that the value shall never be used. This is usually to avoid emulation of start codes.
- 2.1.71 forced updating [video]:** The process by which macroblocks are intra-coded from time-to-time to ensure that mismatch errors between the inverse DCT processes in encoders and decoders cannot build up excessively.
- 2.1.72 forward motion vector [video]:** A motion vector that is used for motion compensation from a reference picture at an earlier time in display order.
- 2.1.73 frame [audio]:** A part of the audio signal that corresponds to audio PCM samples from an Audio Access Unit.
- 2.1.74 free format [audio]:** Any bitrate other than the defined bitrates that is less than the maximum valid bitrate for each layer.
- 2.1.75 future reference picture [video]:** The future reference picture is the reference picture that occurs at a later time than the current picture in display order.
- 2.1.76 granules [Layer II] [audio]:** The set of 3 consecutive subband samples from all 32 subbands that are considered together before quantisation. They correspond to 96 PCM samples.
- 2.1.77 granules [Layer III] [audio]:** 576 frequency lines that carry their own side information.
- 2.1.78 group of pictures [video]:** A series of one or more coded pictures intended to assist random access. The group of pictures is one of the layers in the coding syntax defined in ISO/IEC 11172-2.
- 2.1.79 Hann window [audio]:** A time function applied sample-by-sample to a block of audio samples before Fourier transformation.
- 2.1.80 Huffman coding:** A specific method for entropy coding.
- 2.1.81 hybrid filterbank [audio]:** A serial combination of subband filterbank and MDCT.
- 2.1.82 IMDCT [audio]:** Inverse Modified Discrete Cosine Transform.
- 2.1.83 intensity stereo [audio]:** A method of exploiting stereo irrelevance or redundancy in stereophonic audio programmes based on retaining at high frequencies only the energy envelope of the right and left channels.
- 2.1.84 interlace [video]:** The property of conventional television pictures where alternating lines of the picture represent different instances in time.
- 2.1.85 intra coding [video]:** Coding of a macroblock or picture that uses information only from that macroblock or picture.
- 2.1.86 intra-coded picture; I-picture [video]:** A picture coded using information only from itself.
- 2.1.87 ISO/IEC 11172 (multiplexed) stream [system]:** A bit stream composed of zero or more elementary streams combined in the manner defined in ISO/IEC 11172-1.
- 2.1.88 joint stereo coding [audio]:** Any method that exploits stereophonic irrelevance or stereophonic redundancy.
- 2.1.89 joint stereo mode [audio]:** A mode of the audio coding algorithm using joint stereo coding.
- 2.1.90 layer [audio]:** One of the levels in the coding hierarchy of the audio system defined in this part of the CD.
- 2.1.91 layer [video and systems]:** One of the levels in the data hierarchy of the video and system specifications defined in ISO/IEC 11172-1 and ISO/IEC 11172-2.
- 2.1.92 low frequency enhancement channel [audio]:** A limited bandwidth channel for low frequency audio effects in a multichannel system.
- 2.1.93 luminance (component) [video]:** A matrix, block or single pel representing a monochrome representation of the signal and related to the primary colours in the manner defined in CCIR Rec 601. The symbol used for luminance is Y.

- 2.1.94 macroblock [video]:** The four 8 by 8 blocks of luminance data and the two corresponding 8 by 8 blocks of chrominance data coming from a 16 by 16 section of the luminance component of the picture. Macroblock is sometimes used to refer to the pel data and sometimes to the coded representation of the pel values and other data elements defined in the macroblock layer of the syntax defined in ISO/IEC 11172-2. The usage is clear from the context.
- 2.1.95 mapping [audio]:** Conversion of an audio signal from time to frequency domain by subband filtering and/or by MDCT.
- 2.1.96 masking [audio]:** A property of the human auditory system by which an audio signal cannot be perceived in the presence of another audio signal .
- 2.1.97 masking threshold [audio]:** A function in frequency and time below which an audio signal cannot be perceived by the human auditory system.
- 2.1.98 MDCT [audio]:** Modified Discrete Cosine Transform which corresponds to the Time Domain Aliasing Cancellation Filter Bank.
- 2.1.99 motion compensation [video]:** The use of motion vectors to improve the efficiency of the prediction of pel values. The prediction uses motion vectors to provide offsets into the past and/or future reference pictures containing previously decoded pel values that are used to form the prediction error signal.
- 2.1.100 motion estimation [video]:** The process of estimating motion vectors during the encoding process.
- 2.1.101 motion vector [video]:** A two-dimensional vector used for motion compensation that provides an offset from the coordinate position in the current picture to the coordinates in a reference picture.
- 2.1.102 MS stereo [audio]:** A method of exploiting stereo irrelevance or redundancy in stereophonic audio programmes based on coding the sum and difference signal instead of the left and right channels.
- 2.1.103 multichannel [audio]:** A combination of audio channels used to create a spatial sound field.
- 2.1.104 multilingual [audio]:** A presentation of dialogue in more than one language.
- 2.1.105 non-intra coding [video]:** Coding of a macroblock or picture that uses information both from itself and from macroblocks and pictures occurring at other times.
- 2.1.106 non-tonal component [audio]:** A noise-like component of an audio signal.
- 2.1.107 Nyquist sampling:** Sampling at or above twice the maximum bandwidth of a signal.
- 2.1.108 pack [system]:** A pack consists of a pack header followed by one or more packets. It is a layer in the system coding syntax described in ISO/IEC 11172-1.
- 2.1.109 packet data [system]:** Contiguous bytes of data from an elementary stream present in a packet.
- 2.1.110 packet header [system]:** The data structure used to convey information about the elementary stream data contained in the packet data.
- 2.1.111 packet [system]:** A packet consists of a header followed by a number of contiguous bytes from an elementary data stream. It is a layer in the system coding syntax described in ISO/IEC 11172-1.
- 2.1.112 padding [audio]:** A method to adjust the average length in time of an audio frame to the duration of the corresponding PCM samples, by conditionally adding a slot to the audio frame.
- 2.1.113 past reference picture [video]:** The past reference picture is the reference picture that occurs at an earlier time than the current picture in display order.
- 2.1.114 pel aspect ratio [video]:** The ratio of the nominal vertical height of pel on the display to its nominal horizontal width.
- 2.1.115 pel [video]:** Picture element.
- 2.1.116 picture period [video]:** The reciprocal of the picture rate.
- 2.1.117 picture rate [video]:** The nominal rate at which pictures should be output from the decoding process.

- 2.1.118 picture [video]:** Source, coded or reconstructed image data. A source or reconstructed picture consists of three rectangular matrices of 8-bit numbers representing the luminance and two chrominance signals. The Picture layer is one of the layers in the coding syntax defined in this CD. Note that the term "picture" is always used in this CD in preference to the terms field or frame.
- 2.1.119 polyphase filterbank [audio]:** A set of equal bandwidth filters with special phase interrelationships, allowing for an efficient implementation of the filterbank.
- 2.1.120 prediction [audio]:** The use of a predictor to provide an estimate of the subband sample in one channel from the subband samples in other channels.
- 2.1.121 prediction [video]:** The use of a predictor to provide an estimate of the pel value or data element currently being decoded.
- 2.1.122 predictive-coded picture; P-picture [video]:** A picture that is coded using motion compensated prediction from the past reference picture.
- 2.1.123 prediction error [video]:** The difference between the actual value of a pel or data element and its predictor.
- 2.1.124 predictor [video]:** A linear combination of previously decoded pel values or data elements.
- 2.1.125 presentation channel [audio]:** audio channels at the output of the decoder corresponding to the loudspeaker positions left, centre, right, left surround and right surround.
- 2.1.126 presentation time-stamp; PTS [system]:** A field that may be present in a packet header that indicates the time that a presentation unit is presented in the system target decoder.
- 2.1.127 presentation unit; PU [system]:** A decoded audio access unit or a decoded picture.
- 2.1.128 psychoacoustic model [audio]:** A mathematical model of the masking behaviour of the human auditory system.
- 2.1.129 quantisation matrix [video]:** A set of sixty-four 8-bit values used by the dequantiser.
- 2.1.130 quantised DCT coefficients [video]:** DCT coefficients before dequantisation. A variable length coded representation of quantised DCT coefficients is stored as part of the compressed video bit stream.
- 2.1.131 quantiser scalefactor [video]:** A data element represented in the bit stream and used by the decoding process to scale the dequantisation.
- 2.1.132 random access:** The process of beginning to read and decode the coded bit stream at an arbitrary point.
- 2.1.133 reference picture [video]:** Reference pictures are the nearest adjacent I- or P-pictures to the current picture in display order.
- 2.1.134 reorder buffer [video]:** A buffer in the system target decoder for storage of a reconstructed I-picture or a reconstructed P-picture.
- 2.1.135 requantisation [audio]:** Decoding of coded subband samples in order to recover the original quantised values.
- 2.1.136 reserved:** The term "reserved" when used in the clauses defining the coded bit stream indicates that the value may be used in the future for ISO/IEC defined extensions.
- 2.1.137 reverse playback [video]:** The process of displaying the picture sequence in the reverse of display order.
- 2.1.138 scalefactor band [audio]:** A set of frequency lines in Layer III which are scaled by one scalefactor.
- 2.1.139 scalefactor index [audio]:** A numerical code for a scalefactor.
- 2.1.140 scalefactor [audio]:** Factor by which a set of values is scaled before quantisation.
- 2.1.141 sequence header [video]:** A block of data in the coded bit stream containing the coded representation of a number of data elements.
- 2.1.142 side information:** Information in the bit stream necessary for controlling the decoder.

- 2.1.143 skipped macroblock [video]:** A macroblock for which no data are stored.
- 2.1.144 slice [video]:** A series of macroblocks. It is one of the layers of the coding syntax defined in ISO/IEC 11172-2.
- 2.1.145 slot [audio]:** A slot is an elementary part in the bit stream. In Layer I a slot equals four bytes, in Layers II and III one byte.
- 2.1.146 source stream:** A single non-multiplexed stream of samples before compression coding.
- 2.1.147 spreading function [audio]:** A function that describes the frequency spread of masking effects.
- 2.1.148 start codes [system and video]:** 32-bit codes embedded in that coded bit stream that are unique. They are used for several purposes including identifying some of the layers in the coding syntax.
- 2.1.149 STD input buffer [system]:** A first-in first-out buffer at the input of the system target decoder for storage of compressed data from elementary streams before decoding.
- 2.1.150 stereo-irrelevant [audio]:** a portion of a stereophonic audio signal which does not contribute to spatial perception.
- 2.1.151 stereo mode [audio]:** Mode, where two audio channels which form a stereo pair (left and right) are encoded within one bit stream. The coding process is the same as for the dual channel mode.
- 2.1.152 stuffing (bits); stuffing (bytes) :** Code-words that may be inserted into the compressed bit stream that are discarded in the decoding process. Their purpose is to increase the bitrate of the stream.
- 2.1.153 subband [audio]:** Subdivision of the audio frequency band.
- 2.1.154 subband filterbank [audio]:** A set of band filters covering the entire audio frequency range. In this part of the CD, the subband filterbank is a polyphase filterbank.
- 2.1.155 subband samples [audio]:** The subband filterbank within the audio encoder creates a filtered and subsampled representation of the input audio stream. The filtered samples are called subband samples. From 384 time-consecutive input audio samples, 12 time-consecutive subband samples are generated within each of the 32 subbands.
- 2.1.156 surround channel [audio]:** An audio presentation channel added to the front channels (L and R or L, R, and C) to enhance the spatial perception.
- 2.1.157 syneword [audio]:** A 12-bit code embedded in the audio bit stream that identifies the start of a frame.
- 2.1.158 synthesis filterbank [audio]:** Filterbank in the decoder that reconstructs a PCM audio signal from subband samples.
- 2.1.159 system header [system]:** The system header is a data structure defined in ISO/IEC 11172-1 that carries information summarising the system characteristics of the ISO/IEC 11172 multiplexed stream.
- 2.1.160 system target decoder; STD [system]:** A hypothetical reference model of a decoding process used to describe the semantics of an ISO/IEC 11172 multiplexed bit stream.
- 2.1.161 time-stamp [system]:** A term that indicates the time of an event.
- 2.1.162 triplet [audio]:** A set of 3 consecutive subband samples from one subband. A triplet from each of the 32 subbands forms a granule.
- 2.1.163 tonal component [audio]:** A sinusoid-like component of an audio signal.
- 2.1.164 variable bitrate:** Operation where the bitrate varies with time during the decoding of a compressed bit stream.
- 2.1.165 variable length coding; VLC:** A reversible procedure for coding that assigns shorter code-words to frequent events and longer code-words to less frequent events.

**2.1.166 video buffering verifier; VBV [video]:** A hypothetical decoder that is conceptually connected to the output of the encoder. Its purpose is to provide a constraint on the variability of the data rate that an encoder or editing process may produce.

**2.1.167 video sequence [video]:** A series of one or more groups of pictures. It is one of the layers of the coding syntax defined in ISO/IEC 11172-2.

**2.1.168 zigzag scanning order [video]:** A specific sequential ordering of the DCT coefficients from (approximately) the lowest spatial frequency to the highest.

## 2.2 Symbols and abbreviations

The mathematical operators used to describe this Recommendation | International Standard are similar to those used in the C programming language. However, integer division with truncation and rounding are specifically defined. The bitwise operators are defined assuming twos-complement representation of integers. Numbering and counting loops generally begin from zero.

### 2.2.1 Arithmetic operators

+	Addition.
–	Subtraction (as a binary operator) or negation (as a unary operator).
++	Increment.
--	Decrement.
*	Multiplication.
^	Power.
/	Integer division with truncation of the result toward zero. For example, $7/4$ and $-7/-4$ are truncated to 1 and $-7/4$ and $7/-4$ are truncated to $-1$ .
//	Integer division with rounding to the nearest integer. Half-integer values are rounded away from zero unless otherwise specified. For example $3//2$ is rounded to 2, and $-3//2$ is rounded to $-2$ .
DIV	Integer division with truncation of the result towards $-\infty$ .
	Absolute value. $ x  = x$ when $x > 0$ $ x  = 0$ when $x == 0$ $ x  = -x$ when $x < 0$
%	Modulus operator. Defined only for positive numbers.
Sign( )	Sign. $\text{Sign}(x) = 1$ when $x > 0$ $\text{Sign}(x) = 0$ when $x == 0$ $\text{Sign}(x) = -1$ when $x < 0$
NINT( )	Nearest integer operator. Returns the nearest integer value to the real-valued argument. Half-integer values are rounded away from zero.
sin	Sine.
cos	Cosine.
exp	Exponential.
$\sqrt{\quad}$	Square root.
log <sub>10</sub>	Logarithm to base ten.
log <sub>e</sub>	Logarithm to base e.

log<sub>2</sub>      Logarithm to base 2.

### 2.2.2 Logical operators

||          Logical OR.

&&        Logical AND.

!          Logical NOT

### 2.2.3 Relational operators

>          Greater than.

>=        Greater than or equal to.

<          Less than.

<=        Less than or equal to.

==        Equal to.

!=        Not equal to.

max [...,] the maximum value in the argument list.

min [...,] the minimum value in the argument list.

### 2.2.4 Bitwise operators

A twos complement number representation is assumed where the bitwise operators are used.

&          AND

|          OR

>>        Shift right with sign extension.

<<        Shift left with zero fill.

### 2.2.5 Assignment

=          Assignment operator.

### 2.2.6 Mnemonics

The following mnemonics are defined to describe the different data types used in the coded bit stream.

bslbf              Bit string, left bit first, where "left" is the order in which bit strings are written in ISO/IEC 13818. Bit strings are written as a string of 1s and 0s within single quote marks, e.g. '1000 0001'. Blanks within a bit string are for ease of reading and have no significance.

centre\_chan        Index of centre channel.

centre\_limited     Variable which indicates whether a subband of the centre is not transmitted. It is used in the case of Phantom coding of centre channel.

ch                 Channel. If ch has the value 0, the left channel of a stereo signal or the first of two independent signals is indicated.

dyn_cross	dyn_cross means that dynamic crosstalk is used for a certain transmission channel and a certain subband.
gr	Granule of 3 * 32 subband samples in audio Layer II, 18 * 32 subband samples in audio Layer III.
Lo, Ro	Compatible stereo audio signals.
L, C, R, LS, RS	Left, centre, right, left surround and right surround audio signals.
L <sup>w</sup> , C <sup>w</sup> , R <sup>w</sup> , LS <sup>w</sup> , RS <sup>w</sup>	Weighted left, centre, right, left surround and right surround audio signals. The weighting is necessary for two reasons: 1) All signals have to be attenuated prior to encoding to avoid overload when calculating the compatible stereo signal. 2) The matrix equations contain attenuation factors and other processing like phase shifting. The weighted and processed signals are actually coded and transmitted, and denormalised in the decoder.
left_sur_chan	Index of left surround channel.
main_data	The main_data portion of the bit stream contains the scalefactors, Huffman encoded data, and ancillary information.
mono_sur_chan	Index of the mono surround channel. This index is identical to the index of the left surround channel.
msblimit	Maximum used subband.
nch	Number of channels; equal to 1 for single_channel mode, 2 in other modes.
nmch	Number of channels in the multichannel extension part.
npred	Number of allowed predictors according to the tables in subclause 2.5.2.10.
npredcoeff	Number of prediction coefficients used.
part2_length	The number of main_data bits used for scalefactors.
pci	index of predictor[0, 1, 2].
px	index of predictor[0, 1, ..., npred-1].
right_sur_chan	Index of right surround channel.
rpchof	Remainder polynomial coefficients, highest order first.
sb	Subband.
sbgr	Groups of individual subbands according to subbandgroup table in subclause 2.5.2.10.
sblimit	The number of the lowest subband for which no bits are allocated.
scfsi	Scalefactor selection information.
switch_point_l	Number of scalefactor band (long block scalefactor band) from which point on window switching is used.
switch_point_s	Number of scalefactor band (short block scalefactor band) from which point on window switching is used.
T0, T1, T2, T3, T4	Audio transmission channels. The assignment of audio signals to transmission channels is determined by the dematrixing procedure and the transmission channel allocation information.
tc	Transmitted channel.
uimsbf	Unsigned integer, most significant bit first.

vclbf	Variable length code, left bit first, where "left" refers to the order in which the VLC codes are written.
window	Number of the actual time slot in case of block_type==2, 0 <= window <= 2. (Layer III)

The byte order of multi-byte words is most significant byte first.

### 2.2.7 Constants

$\pi$	3,14159265358...
e	2,71828182845...

### 2.3 Method of describing bit stream syntax

The bit stream retrieved by the decoder is described in 2.4.1 and 2.5.1. Each data item in the bit stream is in bold type. It is described by its name, its length in bits, and a mnemonic for its type and order of transmission.

The action caused by a decoded data element in a bit stream depends on the value of that data element and on data elements previously decoded. The decoding of the data elements and the definition of the state variables used in their decoding are described in 2.4.2, 2.4.3, 2.5.2 and 2.5.3. The following constructs are used to express the conditions when data elements are present, and are in normal type:

Note this syntax uses the 'C'-code convention that a variable or expression evaluating to a non-zero value is equivalent to a condition that is true.

while ( condition ) {  
**data\_element**  
 ...  
}

If the condition is true, then the group of data elements occurs next in the data stream. This repeats until the condition is not true.

do {  
**data\_element**  
 ...  
} while ( condition )

The data element always occurs at least once. The data element is repeated until the condition is not true.

if ( condition ) {  
**data\_element**  
 ...  
}  
else {  
**data\_element**  
 ...  
}

If the condition is true, then the first group of data elements occurs next in the data stream

If the condition is not true, then the second group of data elements occurs next in the data stream.

for (expr1; expr2; expr3) {  
**data\_element**  
 ...  
}

Expr1 is an expression specifying the initialisation of the loop. Normally it specifies the initial state of the counter. Expr2 is a condition specifying a test made before each iteration of the loop. The loop terminates when the condition is not true. Expr3 is an expression that is performed at the end of each iteration of the loop, normally it increments a counter.

Note that the most common usage of this construct is as follows:



for ( i = 0; i < n; i++) {      The group of data elements occurs n times. Conditional constructs within the  
     **data\_element**              group of data elements may depend on the value of the loop control variable i,  
     ...                              which is set to zero for the first occurrence, incremented to one for the second  
 }                                      occurrence, and so forth.

As noted, the group of data elements may contain nested conditional constructs. For compactness, the {} may be omitted when only one data element follows.

**data\_element [ ]**              data\_element [ ] is an array of data. The number of data elements is indicated by the context.

**data\_element [n]**              data\_element [n] is the n+1th element of an array of data.

**data\_element [m][n]**          data\_element [m][n] is the m+1,n+1 th element of a two-dimensional array of data.

**data\_element [l][m][n]**      data\_element [l][m][n] is the l+1,m+1,n+1 th element of a three-dimensional array of data.

**data\_element [m..n]**          data\_element [m..n] is the inclusive range of bits between bit m and bit n in the data\_element.

While the syntax is expressed in procedural terms, it should not be assumed that clause 2.4.3 implements a satisfactory decoding procedure. In particular, it defines a correct and error-free input bit stream. Actual decoders must include a means to look for start codes in order to begin decoding correctly.

#### Definition of bytealigned function

The function bytealigned ( ) returns 1 if the current position is on a byte boundary, that is the next bit in the bit stream is the first bit in a byte. Otherwise it returns 0.

#### Definition of nextbits function

The function nextbits ( ) permits comparison of a bit string with the next bits to be decoded in the bit stream.

#### Definition of next\_start\_code function

The next\_start\_code function removes any zero bit and zero byte stuffing and locates the next start code.

Syntax	No. of bits	Mnemonic
next_start_code() { while ( !bytealigned() ) <b>zero_bit</b>	'1'	'0'
while ( nextbits() != '0000 0000 0000 0000 0000 0001' ) <b>zero_byte</b>	8	'00000000'
}		

This function checks whether the current position is bytealigned. If it is not, zero stuffing bits are present. After that any number of zero bytes may be present before the start-code. Therefore start-codes are always bytealigned and may be preceded by any number of zero stuffing bits.

## 2.4 Requirements for Extension of ISO/IEC 11172-3 Audio Coding to Lower Sampling Frequencies

### 2.4.1 Specification of the Coded Audio Bit stream Syntax

#### 2.4.1.1 Layer I, II

see ISO/IEC 11172-3, subclause 2.4.1

#### 2.4.1.2 Layer III

Syntax	No. of bits	Mnemonic
audio_data() {		
<b>main_data_begin</b>	8	uimsbf
if (mode==single_channel)		
<b>private_bits</b>	1	bslbf
else		
<b>private_bits</b>	2	bslbf
for (ch=0; ch<nch; ch++) {		
<b>part2_3_length[ch]</b>	12	uimsbf
<b>big_values[ch]</b>	9	uimsbf
<b>global_gain[ch]</b>	8	uimsbf
<b>scalefac_compress[ch]</b>	9	bslbf
<b>window_switching_flag[ch]</b>	1	bslbf
if (window_switching_flag[ch]) {		
<b>block_type[ch]</b>	2	bslbf
<b>mixed_block_flag[ch]</b>	1	uimsbf
for (region=0; region<2; region++)		
<b>table_select[ch][region]</b>	5	bslbf
for (window=0; window<3; window++)		
<b>subblock_gain[ch][window]</b>	3	uimsbf
}		
else {		
for (region=0; region<3; region++)		
<b>table_select[ch][region]</b>	5	bslbf
<b>region0_count[ch]</b>	4	bslbf
<b>region1_count[ch]</b>	3	bslbf
}		
<b>scalefac_scale[ch]</b>	1	bslbf
<b>count1table_select[ch]</b>	1	bslbf
}		
main_data ()		
}		

The main data bit stream is defined below. The main\_data field in the audio\_data() syntax contains bytes from the main data bit stream. However, because of the variable nature of Huffman coding used in Layer III, the main data for a frame does not generally follow the header and side information for that frame. The main\_data for a frame starts at a location in the bit stream preceding the header of the frame at a negative offset given by the value of main\_data\_begin. (See definition of main\_data\_begin in ISO/IEC 11172-3).

Syntax	No. of bits	Mnemonic
<pre> main_data() {   for (ch=0; ch&lt;nch; ch++) {     if ((window_switching_flag[ch]==1) &amp;&amp;         block_type[ch]==2) {       if (mixed_block_flag[ch]) {         for (sfb=0; sfb&lt;8; sfb++)           <b>scalefac_l[ch][sfb]</b>           for (sfb=3; sfb&lt;12; sfb++)             for (window=0; window&lt;3; window++)               <b>scalefac_s[ch][sfb][window]</b>         }       }       else {         for (sfb=0; sfb&lt;12; sfb++)           for (window=0; window&lt;3; window++)             <b>scalefac_s[ch][sfb][window]</b>         }       }     }     else {       for (sfb=0; sfb&lt;21; sfb++)         <b>scalefac_l[ch][sfb]</b>     }     Huffmancodebits()   }   for (b=0; b&lt;no_of_ancillary_bits; b++)     <b>ancillary_bit</b> } </pre>	0.4	uimsbf
	0.5	uimsbf
	0.5	uimsbf
	0.5	uimsbf
	1	bslbf

Huffmancodebits see ISO/IEC 11172-3, subclause 2.4.1.7

## 2.4.2 Semantics for the Audio Bit stream Syntax

### 2.4.2.1 Audio Sequence General

See ISO/IEC 11172-3, subclause 2.4.2.1

### 2.4.2.2 Audio Frame

See ISO/IEC 11172-3, subclause 2.4.2.2

### 2.4.2.3 Header

The first 32 bits (four bytes) are header information which is common to all layers.

**syncword** - See ISO/IEC 11172-3, subclause 2.4.2.3

**ID** - One bit to indicate the ID of the algorithm. Equals '1' for ISO/IEC 11172-3, '0' for extension to lower sampling frequencies.

**Layer** - See ISO/IEC 11172-3, subclause 2.4.2.3

**protection\_bit** - See ISO/IEC 11172-3, subclause 2.4.2.3

**bitrate\_index** - Four bits to indicate the bitrate. The all zero value indicates the 'free format' condition, in which a fixed bitrate which does not need to be in the list can be used. Fixed means that a frame contains either N or N+1 slots, depending on the value of the padding bit. The bitrate\_index is an index to a table, which is different for each layer.

The bitrate\_index indicates the total bitrate irrespective of the mode (stereo, joint\_stereo, dual\_channel, single\_channel), according to the following table for ID=0.

bitrate_index	bitrate specified (kbit/s) for Fs = 16, 22,05, 24 kHz	
	Layer I	Layer II, Layer III
'0000'	free	free
'0001'	32	8
'0010'	48	16
'0011'	56	24
'0100'	64	32
'0101'	80	40
'0110'	96	48
'0111'	112	56
'1000'	128	64
'1001'	144	80
'1010'	160	96
'1011'	176	112
'1100'	192	128
'1101'	224	144
'1110'	256	160
'1111'	forbidden	forbidden

The decoder is not required to support bitrates higher than 256 kbit/s, 160 kbit/s, 160 kbit/s in respect to Layer I, II and III when in free format mode.

**sampling\_frequency** - Indicates the sampling frequency for ID='0', according to the following table.

sampling_frequency	frequency specified (kHz)
'00'	22,05
'01'	24
'10'	16
'11'	reserved

A reset of the audio decoder may be required to change the sampling rate.

**padding\_bit** - See ISO/IEC 11172-3, subclause 2.4.2.3. Padding is necessary with a sampling frequency of 22,05 kHz. Padding may also be required in free format.

**private\_bit** - See ISO/IEC 11172-3, subclause 2.4.2.3

**mode** - See ISO/IEC 11172-3, subclause 2.4.2.3

**mode\_extension** - See ISO/IEC 11172-3, subclause 2.4.2.3

**copyright** - See ISO/IEC 11172-3, subclause 2.4.2.3

**original/copy** - See ISO/IEC 11172-3, subclause 2.4.2.3

**emphasis** - See ISO/IEC 11172-3, subclause 2.4.2.3

#### 2.4.2.4 Error Check

For Layer I and Layer II, see ISO/IEC 11172-3, subclause 2.4.2.4.

For Layer III, the bits used to calculate the error check are:

bits 16..31 of the header	
bits 0..71 of audio_data	for single channel mode,
bits 0..135 of audio_data	for other modes

#### 2.4.2.5 Audio Data Layer I

See ISO/IEC 11172-3, subclause 2.4.2.5

#### 2.4.2.6 Audio Data Layer II

See ISO/IEC 11172-3, subclause 2.4.2.6

#### 2.4.2.7 Audio Data Layer III

See ISO/IEC 11172-3, subclause 2.4.2.7 with the exception of a different definition of `scalefac_compress`.

**scalefac\_compress**[ch] - Selects the number of bits used for the transmission of the scalefactors and sets or resets preflag. If preflag is set, the values of a table are added to the scalefactors as described in ISO/IEC 11172-3 (Table B.6 Annex B).

#### 2.4.2.8 Ancillary Data

See ISO/IEC 11172-3, subclause 2.4.1.8

### 2.4.3 The Audio Decoding Process

#### 2.4.3.1 Audio Decoding Layer I, II

See ISO/IEC 11172-3, subclause 2.4.3. For Layer II, instead of tables B.2 (Layer II bit allocation tables) in ISO/IEC 11172-3, table B.1 (Possible quantisation per subband, Layer II) of this Recommendation | International Standard should be used.

#### 2.4.3.2 Audio Decoding Layer III

Decoding of Layer III Low Sampling Frequencies is performed as for Layer III in ISO/IEC 11172-3 with the following differences:

- If intensity stereo is selected, the maximum value for intensity position will indicate an illegal intensity position. As in ISO/IEC 11172-3 scalefactor bands with an illegal intensity position have to be decoded according to the MS equations as defined in ISO/IEC 11172-3 if MS stereo is enabled, or both channels independently if MS stereo is not enabled.
- As in ISO/IEC 11172-3 the last scalefactor band which is not intensity coded is equal to the last scalefactor band in the right channel which is not completely zero, and in which the corresponding scalefactor does not indicate illegal intensity position. Unlike ISO/IEC 11172-3 decoding of the lower bound for intensity stereo is performed

individually for each window in the case of short blocks (`block_type == 2`). This means that, unlike in ISO/IEC 11172-3 subclause 2.4.3.4, the calculation of the intensity bound is applied to the values of each short window and permits individual intensity stereo decoding per short window.

- Steps 4 and 5 of the described decoding process for intensity stereo decoding are modified as follows:

$$\begin{aligned} 4) \quad R_i &:= L_i * k_r \\ 5) \quad L_i &:= L_i * k_l \end{aligned}$$

The values  $k_l$  and  $k_r$  are calculated from the transmitted scalefactor / `is_pos_sb` value as follows:

$$\begin{aligned} \text{if } (is\_pos\_sb == 0) & \quad k_l = 1.0 & \quad k_r = 1.0 \\ \text{else if } (is\_pos\_sb \% 2 == 1) & \quad k_l = i_0^{(is\_pos\_sb+1)/2} & \quad k_r = 1.0 \\ \text{else} & \quad k_l = 1.0 & \quad k_r = i_0^{is\_pos\_sb/2} \end{aligned}$$

The basic intensity stereo decoding factor  $i_0$  is determined by `intensity_scale` ( $1/\sqrt{2}$  for `intensity_scale == 1`, else  $1/\sqrt[3]{2}$ ). The value of `intensity_scale` is derived from the value of `scalefac_compress` of the right channel according to:

$$intensity\_scale = scalefac\_compress \% 2$$

- The paragraph “Scalefactors” in ISO/IEC 11172-3 subclause 2.4.3.4 has to be replaced by the following text:

#### Scalefactors

The scalefactors are decoded according to the `slen1`, `slen2`, `slen3`, and `slen4` and `nr_of_sfb1`, `nr_of_sfb2`, `nr_of_sfb3`, and `nr_of_sfb4` which are determined from the values of `scalefac_compress`.

The number of bits used to encode scalefactors is called `part2_length`, and is calculated as follows:

$$part2\_length = nr\_of\_sfb1 * slen1 + nr\_of\_sfb2 * slen2 + nr\_of\_sfb3 * slen3 + nr\_of\_sfb4 * slen4$$

The scalefactors are transmitted in four partitions. The number of scalefactors in each partition (`nr_of_sfb1`, `nr_of_sfb2`, `nr_of_sfb3`, and `nr_of_sfb4`), the length of the scalefactors in each partition (`slen1`, `slen2`, `slen3`, and `slen4`), and `preflag` are decoded from `scalefac_compress` according to the following procedure:

```
if (!(mode_extension==01) || (mode_extension==11) ) && (ch==1) ){
  if ( scalefac_compress < 400 ) {
    slen1 = (scalefac_compress >> 4) / 5
    slen2 = (scalefac_compress >> 4) % 5
    slen3 = (scalefac_compress % 16) >> 2
    slen4 = scalefac_compress % 4
    preflag = 0

| block_type | mixed_block_flag | nr_of_sfb1 | nr_of_sfb2 | nr_of_sfb3 | nr_of_sfb4 |
|------------|------------------|------------|------------|------------|------------|
| 0, 1, 3    | x                | 6          | 5          | 5          | 5          |
| 2          | 0                | 9          | 9          | 9          | 9          |
| 2          | 1                | 6          | 9          | 9          | 9          |

```

```

if (500 <= scalefac_compress < 512 ) {
    slen1 = (scalefac_compress-500) / 3
    slen2 = (scalefac_compress-500) % 3
    slen3 = 0
    slen4 = 0
    preflag = 1

| block_type | mixed_block_flag | nr_of_sfb1 | nr_of_sfb2 | nr_of_sfb3 | nr_of_sfb4 |
|------------|------------------|------------|------------|------------|------------|
| 0, 1, 3    | x                | 11         | 10         | 0          | 0          |
| 2          | 0                | 18         | 18         | 0          | 0          |
| 2          | 1                | 15         | 18         | 0          | 0          |

}
}
if ( (mode_extension==01) || (mode_extension==11) ) && (ch==1) {
    intensity_scale = scalefac_compress % 2
    int_scalefac_compress = scalefac_compress >> 1
    if (int_scalefac_compress < 180 ) {
        slen1 = int_scalefac_compress / 36
        slen2 = (int_scalefac_compress % 36) / 6
        slen3 = (int_scalefac_compress % 36) % 6
        slen4 = 0
        preflag = 0

| block_type | mixed_block_flag | nr_of_sfb1 | nr_of_sfb2 | nr_of_sfb3 | nr_of_sfb4 |
|------------|------------------|------------|------------|------------|------------|
| 0, 1, 3    | x                | 7          | 7          | 7          | 0          |
| 2          | 0                | 12         | 12         | 12         | 0          |
| 2          | 1                | 6          | 15         | 12         | 0          |

}
    if (180 <= int_scalefac_compress < 244) {
        slen1 = ((int_scalefac_compress-180) % 64) >> 4
        slen2 = ((int_scalefac_compress-180) % 16) >> 2
        slen3 = (int_scalefac_compress-180) % 4
        slen4 = 0
        preflag = 0

| block_type | mixed_block_flag | nr_of_sfb1 | nr_of_sfb2 | nr_of_sfb3 | nr_of_sfb4 |
|------------|------------------|------------|------------|------------|------------|
| 0, 1, 3    | x                | 6          | 6          | 6          | 3          |
| 2          | 0                | 12         | 9          | 9          | 6          |
| 2          | 1                | 6          | 12         | 9          | 6          |

}
    if (244 <= int_scalefac_compress < 255) {
        slen1 = (int_scalefac_compress-244) / 3
        slen2 = (int_scalefac_compress-244) % 3
        slen3 = 0
        slen4 = 0
        preflag = 0

| block_type | mixed_block_flag | nr_of_sfb1 | nr_of_sfb2 | nr_of_sfb3 | nr_of_sfb4 |
|------------|------------------|------------|------------|------------|------------|
| 0, 1, 3    | x                | 8          | 8          | 5          | 0          |
| 2          | 0                | 15         | 12         | 9          | 0          |
| 2          | 1                | 6          | 18         | 9          | 0          |

}
}
}

```

In scalefactor bands where slen1, slen2, slen3 or slen4 is zero and the corresponding nr\_of\_slen1, nr\_of\_slen2, nr\_of\_slen3 or nr\_of\_slen4 is not zero, the scalefactors of these bands must be set to zero, resulting in an intensity position of zero.

## 2.5 Requirements for low bitrate coding of multichannel audio

### 2.5.1 Specification of the Coded Audio Bit stream Syntax

#### 2.5.1.1 Audio Sequence

See ISO/IEC 11172-3, subclause 2.4.1.1

#### 2.5.1.2 Audio Frame Layer I

```

frame()
{
    mpeg1_header()
    mpeg1_error_check()
    mpeg1_audio_data()
    mc_extension_data_part1()
    continuation_bit
    mpeg1_header()
    mpeg1_error_check()
    mpeg1_audio_data()
    mc_extension_data_part2()
    continuation_bit
    mpeg1_header()
    mpeg1_error_check()
    mpeg1_audio_data()
    mc_extension_data_part3()
    mpeg1_ancillary_data()
}

```

#### 2.5.1.3 Audio Frame Layer II, III

```

frame()
{
    mpeg1_header()
    mpeg1_error_check()
    mpeg1_audio_data()
    mc_extension_data_part1()
    if layer<3
        mpeg1_ancillary_data()
}

mc_extension_data()
{
    if (layer==1)
    {
        mc_extension_data_part1()
        mc_extension_data_part2()
        mc_extension_data_part3()
    }
    else
        mc_extension_data_part1()
    if (ext_bit_stream_present=='1'

```



```

    ext_data()
}

```

#### 2.5.1.4 MC\_extension

```

mc_extension()
{
    if layer==3
        mpeg1_ancillary_data()
    mc_header()
    mc_error_check()
    mc_composite_status_info()
    mc_audio_data()
    if (layer < 3)
        ml_audio_data()
}

```

#### 2.5.1.5 MPEG1 Header

see ISO/IEC 11172-3, subclause 2.4.1.3

#### 2.5.1.6 MPEG1 Error Check

see ISO/IEC 11172-3, subclause 2.4.1.4

#### 2.5.1.7 MPEG1 Audio Data

see ISO/IEC 11172-3, subclause 2.4.1.5, subclause 2.4.1.6, subclause 2.4.1.7

#### 2.5.1.8 MC Header

Syntax	No. of bits	Mnemonic
mc_header()		
{		
<b>ext_bit_stream_present</b>	1	bslbf
if ext_bit_stream_present=='1'		
<b>n_ad_bytes</b>	8	uimsbf
<b>centre</b>	2	bslbf
<b>surround</b>	2	bslbf
<b>lfe</b>	1	bslbf
<b>audio_mix</b>	1	bslbf
<b>dematrix_procedure</b>	2	bslbf
<b>no_of_multi_lingual_ch</b>	3	uimsbf
<b>multi_lingual_fs</b>	1	bslbf
<b>multi_lingual_layer</b>	1	bslbf
<b>copyright_identification_bit</b>	1	bslbf
<b>copyright_identification_start</b>	1	bslbf
}		

## 2.5.1.9 MC Error Check

Syntax	No. of bits	Mnemonic
mc_error_check() { <b>mc_crc_check</b> }	16	rpchof

## 2.5.1.10 MC Composite Status Information Layer I, II

Syntax	No. of bits	Mnemonic
mc_composite_status_info() { <b>tc_sbgr_select</b> <b>dyn_cross_on</b> <b>mc_prediction_on</b> if tc_sbgr_select == 1 { <b>tc_allocation</b> for (sbgr=0; sbgr<12; sbgr++) tc_allocation[sbgr] = tc_allocation } else for (sbgr=0; sbgr<12; sbgr++) <b>tc_allocation[sbgr]</b> if dyn_cross_on==1 { <b>dyn_cross_LR</b> for (sbgr=0; sbgr<12; sbgr++) { <b>dyn_cross_mode[sbgr]</b> if surround==3 <b>dyn_second_stereo[sbgr]</b> } } if mc_prediction_on==1 { for (sbgr=0; sbgr<8; sbgr++) { <b>mc_prediction[sbgr]</b> if (mc_prediction[sbgr]==1) for (px=0; px<npred; px++) <b>predsi[sbgr,px]</b> } } } } }	1 1 1 2..3 2..3 1 1..4 1 1 2	bslbf bslbf bslbf uimsbf uimsbf bslbf bslbf bslbf bslbf

## 2.5.1.11 MC Composite Status Information Layer III

Syntax	No. of bits	Mnemonic
mc_composite_status_info() { <b>mc_data_begin</b> }	11	uimsbf

for(gr=0;gr<2; gr++)		
for ( ch=2; ch<4; ch++) {		
<b>seg_list_present[gr][ch]</b>	1	bslbf
<b>tc_present[gr][ch]</b>	1	bslbf
<b>block_type[gr][ch]</b>	2	bslbf
}		
if (centre!='00') {		
for(gr=0;gr<2;gr++) {		
<b>seg_list_present[gr][centre_chan]</b>	1	bslbf
<b>tc_present[gr][centre_chan]</b>	1	bslbf
<b>block_type[gr][centre_chan]</b>	2	bslbf
}		
}		
if (surround=='01') {		
for(gr=0;gr<2;gr++) {		
<b>seg_list_present[gr][mono_surr_chan]</b>	1	bslbf
<b>tc_present[gr][mono_surr_chan]</b>	1	bslbf
<b>block_type[gr][mono_surr_chan]</b>	2	bslbf
}		
}		
if (surround=='10'    surround=='11') {		
for(gr=0;gr<2;gr++)		
for ( ch=left_surr_chan; ch<=right_surr_chan; ch++) {		
<b>seg_list_present[gr][ch]</b>	1	bslbf
<b>tc_present[gr][ch]</b>	1	bslbf
<b>block_type[gr][ch]</b>	2	bslbf
}		
}		
if (dematrix_procedure != 3)		
<b>dematrix_length</b>	4	bslbf
else		
dematrix_length = 0		
for ( sbgr=0; sbgr<dematrix_length; sbgr++)		
<b>dematrix_select[sbgr]</b>	3..4	bslbf
for ( gr=0; gr<2; gr++)		
for( ch=2; ch<7; ch++) {		
if ( ch_present(ch) && seg_list_present[gr][ch] ) {		
<b>seg_list_nodef[gr][ch]</b>	1	bslbf
if ( seg_list_nodef[gr][ch] ) {		
if ( gr==1 && seg_list_present[gr_0][ch] &&		
seg_list_nodef[gr_0][ch] ) {		
<b>segment_list_repeat[ch]</b>	1	bslbf
if ( !segment_list_repeat[ch] ) {		
<b>segment_list( gr,ch )</b>		
}		
}		
}		
}		
else		
<b>segment_list( gr,ch)</b>		
}		
}		
}		
}		
<b>mc_prediction_on</b>	1	bslbf

<pre> if (mc_prediction_on) {     for (sbgr=0; sbgr&lt; 15; sbgr++)         <b>mc_prediction[sbgr]</b> </pre>	1	bslbf
<pre>     for (sbgr=0; sbgr&lt; 15; sbgr++) {         if (mc_prediction_sbgr[sbgr]) {             for (pci=0; pci&lt;npredcoef; pci++)                 <b>predsi[sbgr][pci]</b>             }         }     } </pre>	1	bslbf
<pre>     for (sbgr=0; sbgr&lt; 15; sbgr++) {         for (pci=0; pci&lt;npredcoef; pci++) {             if (predsi[sbgr][pci])                 <b>pred_coef[sbgr][pci]</b>         }     } } </pre>	3	uimsbf

The segment list syntax is defined below.

Syntax	No. of bits	Mnemonic
<pre> segment_list( gr,ch) {     seg = 0     sbgr = dematrix_length     if ( block_type[gr][ch] == 2 ) sbgr_cnt = 12 else sbgr_cnt = 15     <b>attenuation_range[gr][ch]</b>     <b>attenuation_scale[gr][ch]</b>     while (sbgr &lt; sbgr_cnt) {         <b>seg_length[gr][ch][seg]</b>         if (seg_length[gr][ch][seg] == 0)             break;         <b>tc_select[gr][ch][seg]</b>         if (tc_select[gr][ch][seg] != 7 &amp;&amp; tc_select[gr][ch][seg] != ch )             for (sbgr1=sbgr; sbgr1&lt;sbgr+seg_length[gr][ch][seg]; sbgr1++)                 <b>attenuation[gr][ch][seg][sbgr1]</b>         sbgr += seg_length[gr][ch][seg]         seg++     } } </pre>	2	uimsbf
	1	uimsbf
	4	uimsbf
	3	uimsbf
	2...5	uimsbf

### 2.5.1.12 MC Audio Data, Layer I and Layer II

Syntax	No. of bits	Mnemonic
<pre> mc_audio_data() {     if (lfe==1)         <b>lfe_allocation</b>     for (sb=0; sb&lt;msblimit; sb++)         for (mch=0; mch&lt;nmch; mch++)             if (!centre_limited[mch,sb] &amp;&amp; !dyn_cross[mch,sb])                 <b>allocation[mch,sb]</b> } </pre>	4	uimsbf
	2..4	uimsbf

<pre> else if (centre_limited[mch,sb]) allocation[mch,sb]=0 for (sb=0; sb&lt;msblimit; sb++)   for (mch=0; mch&lt;nmch; mch++)     if (allocation[mch,sb]!=0)       <b>scfsi[mch,sb]</b> if mc_prediction_on==1   for (sbgr=0; sbgr&lt;8; sbgr++)     if (mc_prediction [sbgr]==1)       for (px=0; px&lt;npred; px++)         if (predsi[sbgr,px] !=0)           { <b>delay_comp[sbgr,px]</b>             for (pci=0; pci&lt;predsi[sbgr,px]; pci++)               <b>pred_coef[sbgr,px,pci]</b>           } if (lfe==1)   <b>If_scalefactor</b> for (sb=0; sb&lt;msblimit; sb++)   for (mch=0; mch&lt;nmch; mch++)     if (allocation[mch,sb]!=0)       {         if (scfsi[mch,sb]==0)           { <b>scalefactor[mch,sb,0]</b>             <b>scalefactor[mch,sb,1]</b>             <b>scalefactor[mch,sb,2]</b> }         if (scfsi[mch,sb]==1    scfsi[mch,sb]==3)           { <b>scalefactor[mch,sb,0]</b>             <b>scalefactor[mch,sb,2]</b> }         if (scfsi[mch,sb]==2)           <b>scalefactor[mch,sb,0]</b>       } for (gr=0; gr&lt;12; gr++)   {     if (lfe=='1')       <b>If_sample[gr]</b> for (sb=0; sb&lt;msblimit; sb++)   for (mch=0; mch&lt;nmch; mch++)     if (allocation[mch,sb]!=0)&amp;&amp;(!dyn_cross[mch,sb])       {         if (grouping[mch,sb])           <b>samplecode[mch,sb,gr]</b>         else for (s=0; s&lt;3; s++)           <b>sample[mch,sb,3*gr+s]</b>       }   } } </pre>	2	uimsbf
	3	uimsbf
	8	uimsbf
	6	uimsbf
	6	uimsbf
	6	uimsbf
	6	uimsbf
	6	uimsbf
	2..15	uimsbf
	5..10	uimsbf
	2..16	uimsbf

### 2.5.1.13 MC Audio Data, Layer III

Syntax	No. of bits	Mnemonic
<pre> mc_audio_data() {   if (dematrix_procedure != 3)     <b>matrix_attenuation_present</b>   else </pre>	1	bslbf

```

matrix_attenuation_present = 0
if ( matrix_attenuation_present ) {
  for ( gr=0; gr<2; gr++)
    for ( ch=2; ch<7; ch++)
      if ( block_type[gr][ch] == 2 )
        for ( sbgr=dematrix_length; sbgr<12; sbgr++ )
          if ( js_carrier[gr][ch][sbgr] {
            matrix_attenuation_l[gr][ch][sbgr]      3      bslbf
            matrix_attenuation_r[gr][ch][sbgr]      3      bslbf
          }
        else
          for ( sbgr=dematrix_length; sbgr<15; sbgr++ )
            if ( js_carrier[gr][ch][sbgr] {
              matrix_attenuation_l[gr][ch][sbgr]      3      bslbf
              matrix_attenuation_r[gr][ch][sbgr]      3      bslbf
            }
      }

  for ( tc=2; tc < 7; tc++)
    for ( scfsi_band=0; scfsi_band<4; scfsi_band++)
      if ( tc_present[gr_0][tc] && tc_present[gr_1][tc])
        scfsi[tc][scfsi_band]      1      bslbf
      else
        scfsi[tc][scfsi_band] = 0
  for ( gr=0; gr<2; gr++) {
    for ( tc=2; tc<7; tc++) {
      if ( tc_present[gr][tc] {
        part2_3_length[gr][tc]      12      uimsbf
        big_values[gr][tc]      9      uimsbf
        global_gain[gr][tc]      8      uimsbf
        scalefac_compress[gr][tc]      4      bslbf
        if ( block_type[gr][tc] != 0 ) {
          for ( region=0; region<2; region++)
            table_select[gr][tc][region]      5      bslbf
          if ( block_type[gr][tc] == 2 ) {
            for ( window=0; window<3; window++)
              subblock_gain[gr][tc][window]      3      uimsbf
          }
        }
      }
      else {
        for ( region=0; region<3; region++)
          table_select[gr][tc][region]      5      bslbf
          region0_count[gr][tc]      4      bslbf
          region1_count[gr][tc]      3      bslbf
        }
        preflag[gr][tc]      1      bslbf
        scalefac_scale[gr][tc]      1      bslbf
        count1table_select[gr][tc]      1      bslbf
      }
    }
  }

  if ( lfe )
    LFE_header ()
  if ( no_of_multi_lingual_ch != 0 )

```

<pre> <b>ML_header()</b> while (!bytealigned())   <b>byte_align_bit</b> <b>mc_main_data ()</b> if ( lfe )   <b>lfe_main_data ()</b> if ( no_of_multi_lingual_ch != 0 )   <b>ml_main_data()</b> } </pre>	1	bslbf
---	---	-------

The main data bit stream is defined below. The mc\_main\_data field in the mc\_audio\_data() syntax contains bytes from the main data bit stream. However, because of the variable nature of Huffman coding used in Layer III, the main data for a frame does not generally follow the header and side information for that frame. The mc\_main\_data for a frame starts at a location in the bit stream preceding the header of the frame at a negative offset given by the value of mc\_data\_begin. (See definition of main\_data\_begin of ISO/IEC 11172-3).

Syntax	No. of bits	Mnemonic
<pre> mc_main_data() {   for (gr=0; gr&lt;2; gr++) {     for (tc=2; tc&lt;7; tc++) {       if (tc_present[gr][tc] {         if (block_type[gr][tc]==2) {           for (sfb=0; sfb&lt;12; sfb++)             for (window=0; window&lt;3; window++)               if (data_present[gr][tc][sfb][window] {                 <b>scalefac_s[gr][tc][sfb][window]</b>               }         }         else {           if ((scfsi[tc][0]==0)    (gr == 0))             for(sfb=0;sfb&lt;6; sfb++)               if (data_present[gr][tc][sfb] {                 <b>scalefac_l[gr][tc][sfb]</b>               }           if ((scfsi[tc][1]==0)    (gr == 0))             for(sfb=6;sfb&lt;11; sfb++)               if (data_present[gr][tc][sfb] {                 <b>scalefac_l[gr][tc][sfb]</b>               }           if ((scfsi[tc][2]==0)    (gr == 0))             for(sfb=11; sfb&lt;16; sfb++)               if (data_present[gr][tc][sfb] {                 <b>scalefac_l[gr][tc][sfb]</b>               }           if ((scfsi[tc][3]==0)    (gr == 0))             for(sfb=16; sfb&lt;21; sfb++)               if (data_present[gr][tc][sfb] {                 <b>scalefac_l[gr][tc][sfb]</b>               }         }       }     }   }   <b>Huffmancodebits()</b> } </pre>	0..4	uimsbf
	0..4	uimsbf
	0..4	uimsbf
	0..4	uimsbf
	0..4	uimsbf

```

    }
  }
}

```

Syntax	No. of bits	Mnemonic
Huffmancodebits() {		
for (l=0; l<big_values*2; l+=2) {		
<b>hcod[x][y]</b>	0..19	bslbf
if ( x ==15 && linbits>0)		
<b>linbitsx</b>	1..13	uimsbf
if (x != 0)		
<b>signx</b>	1	bslbf
if ( y ==15 && linbits>0)		
<b>linbitsy</b>	1..13	uimsbf
if (y != 0)		
<b>signy</b>	1	bslbf
is[l] = x		
is[l+1] = y		
}		
for (; l<big_values*2+count1*4; l+=4) {		
<b>hcod[v][w][x][y]</b>	1..6	bslbf
if (v!=0)		
<b>signv</b>	1	bslbf
if (w!=0)		
<b>signw</b>	1	bslbf
if (x!=0)		
<b>signx</b>	1	bslbf
if (y!=0)		
<b>signy</b>	1	bslbf
is[l] = v		
is[l+1] = w		
is[l+2] = x		
is[l+3] = y		
}		
for (; l<576; l++)		
is[l] = 0		
}		

Syntax	No. of bits	Mnemonic
LFE_header () {		
<b>lfe_hc_len</b>	8	uimsbf
<b>lfe_gain</b>	8	uimsbf
<b>lfe_table_select</b>	5	uimsbf
}		

Syntax	No. of bits	Mnemonic
lfe_main_data () {		
for (l=0; l<lfe_bigval; l++) {		
<b>hcod[x][y]</b>	0...19	bslbf
if ( x ==15 && linbits>0)		
<b>linbitsx</b>	1...13	uimsbf



if (x != 0) <b>signx</b>	1	blsbf
if ( y ==15 && linbits>0) <b>linbitsy</b>	1...13	uimsbf
if (y != 0) <b>signy</b>	1	blsbf
is_lfe[gr_0][l] = x is_lfe[gr_1][l] = y } while (l<6) { is_lfe[gr_0][l] = 0; is_lfe[gr_1][l] = 0; l++; } }		

### 2.5.1.14 ML Audio Data, Layer I and Layer II

Syntax	No. of bits	Mnemonic
ml_audio_data() { for (sb=0; sb<mlsblimit; sb++) for (mlch=0; mlch<nmlch; mlch++) <b>allocation[mlch,sb]</b>	2..4	uimsbf
for (sb=0; sb<mlsblimit; sb++) for (mlch=0; mlch<nmlch; mlch++) if (allocation[mlch,sb]!=0) <b>scfsi[mlch,sb]</b>	2	uimsbf
for (sb=0; sb<mlsblimit; sb++) for (mlch=0; mlch<nmlch; mlch++) if (allocation[mlch,sb]!=0) { if (scfsi[mlch,sb]==0) { <b>scalefactor[mlch,sb,0]</b> <b>scalefactor[mlch,sb,1]</b> <b>scalefactor[mlch,sb,2]</b> } if (scfsi[mlch,sb]==1    scfsi[mlch,sb]==3) { <b>scalefactor[mlch,sb,0]</b> <b>scalefactor[mlch,sb,2]</b> } if (scfsi[mlch,sb]==2) <b>scalefactor[mlch,sb,0]</b> } }	6 6 6 6 6 6	uimsbf uimsbf uimsbf uimsbf uimsbf uimsbf
for (gr=0; gr<ngr; gr++) for (sb=0; sb<mlsblimit; sb++) for (mlch=0; mlch<nmlch; mlch++) if (allocation[mlch,sb]!=0) { if (grouping[mlch,sb]) <b>samplecode[mlch,sb,gr]</b> else for (s=0; s<3; s++) <b>sample[mlch,sb,3*gr+s]</b> } }	5..10 2..16	uimsbf uimsbf



```
| } |
```

If `ext_bit_stream_present==0`, see ISO/IEC 11172-3, subclause 2.4.1.8

### 2.5.1.18 Ext\_frame

```
if ext_bit_stream_present=='1'
    ext_frame()
    {
        ext_header()
        ext_data()
        ext_ancillary_data()
    }
```

### 2.5.1.19 Ext\_header

Syntax	No. of bits	Mnemonic
<code>ext_header()</code>		
{		
<b>ext_syncword</b>	12	bslbf
<b>ext_crc_check</b>	16	bslbf
<b>ext_length</b>	11	uimsbf
<b>ext_ID_bit</b>	1	bslbf
}		

### 2.5.1.20 Ext\_ancillary\_data

Syntax	No. of bits	Mnemonic
<code>ext_ancillary_data()</code>		
{		
for (b=0; b<no_of_ancillary_bits; b++)		
<b>ext_ancillary_bit</b>	1	bslbf
}		

## 2.5.2 Semantics for the audio bit stream syntax

### 2.5.2.1 Audio Sequence General

**frame** - Part of the bit stream that is decodable by itself. It contains information for 1152 audio samples for each coded audio channel, 12 samples for the LFE channel, and either 1152 or 576 samples for each multilingual channel. It starts with a syncword, and ends just before the third following syncword in Layer I and just before the next syncword in Layer II or III. It consists of an integer number of slots (four bytes in Layer I, one byte in Layer II or III).

### 2.5.2.2 Audio Frame Layer I

**mpeg1\_header** - Part of the bit stream containing synchronisation and state information.

**mpeg1\_error\_check** - Part of the bit stream containing information for error detection in the MPEG 1 part of the bit stream.

**mpeg1\_audio\_data** - Part of the bit stream containing information on the audio samples of the MPEG 1 part of the bit stream.

**mc\_extension\_data\_part1, mc\_extension\_data\_part2, mc\_extension\_data\_part3** - These three parts plus an optional extension bit stream frame form the complete multichannel extension field 'mc\_extension' of one frame, containing the mc\_header, mc\_error\_check, mc\_composite\_status\_info, mc\_audio\_data and ml\_audio\_data.

**continuation\_bit** - One bit with the value '0', to aid synchronisation.

**mpeg1\_ancillary\_data** - Part of the bit stream that may be used for ancillary data.

### 2.5.2.3 Audio Frame Layer II, III

**mpeg1\_header** - See 2.5.2.2

**mpeg1\_error\_check** - See 2.5.2.2

**mpeg1\_audio\_data** - See 2.5.2.2

**mc\_extension\_data\_part1()** - This part plus an optional extension bit stream frame forms the multichannel extension field, containing the mc\_header, mc\_error\_check, mc\_composite\_status\_info, mc\_audio\_data and ml\_audio\_data.

**mpeg1\_ancillary\_data** - See 2.5.2.2

### 2.5.2.4 MC\_extension

**mc\_header** - Part of the bit stream containing information on the multichannel and multilingual extension of the bit stream.

**mc\_error\_check** - Part of the bit stream containing information for error detection in the multichannel extension part of the bit stream.

**mc\_composite\_status\_info** - Part of the bit stream containing information about the status of the composite coding mode.

**mc\_audio\_data** - Part of the bit stream containing information on the audio samples of the multichannel extension part of the bit stream.

**ml\_audio\_data** - Part of the bit stream containing information on the audio samples of the commentary extension part of the bit stream

### 2.5.2.5 MPEG1 Header

see ISO/IEC 1172-3, subclause 2.4.2.3

### 2.5.2.6 MPEG1 Error Check

see ISO/IEC 11172-3, subclause 2.4.2.4

### 2.5.2.7 MPEG1 Audio Data

see ISO/IEC 11172-3, subclause 2.4.2.5, subclause 2.4.2.6 and subclause 2.4.2.7

### 2.5.2.8 MC Header

**ext\_bit\_stream\_present** - One bit to indicate whether an extension bit stream exists, which contains a remainder of the multichannel and multilingual audio information in case the information does not fit in one MPEG-1 compatible bit stream.

- '0' no extension stream present
- '1' extension bit stream present.

If the value of `ext_bit_stream_present` changes, a reset of the decoder may occur. In case of a variable bit rate application using an extension bit stream, if the required number of bits for a certain frame already fits in the MPEG-1 compatible frame, and consequently does not require an `ext_frame`, the `ext_frame` could consist of only an `ext_header`, to avoid such a reset.

**n\_ad\_bytes** - 8 bits that form an unsigned integer indicating how many bytes are used for the MPEG-1 compatible ancillary data field if an extension bit stream exists.

**centre** - Two bits to indicate whether a centre channel is contained in the multiplex, and to indicate its bandwidth.

- '00' no centre channel present
- '01' centre channel present
- '10' not defined
- '11' centre bandwidth limited (Phantom coding)

If the centre signal is bandwidth limited, the subbands above subband 11 are not transmitted. The decoder shall set the variable `centre_limited[mch,sb]` to true for these subbands, and the allocation of these subbands shall be set to zero:

```
if (centre=='11')
    for (sb=12; sb<msblimit; sb++)
        centre_limited[centre,sb]=true;
```

For those subbands, where `centre_limited[mch,sb]` is true, only transmission channel allocations that include the centre signal can be used.

**surround** - Two bits to indicate whether surround channels are contained in the multiplex.

- '00' no surround
- '01' mono surround
- '10' stereo surround
- '11' no surround, but second stereo programme present

**lfe** - One bit to indicate whether a low frequency enhancement channel is present.

- '0' no low frequency enhancement channel present
- '1' low frequency enhancement channel present

**audio\_mix** - One bit to indicate whether the signal is mixed for a large listening room, like a theatre, or for a small listening room, like a living room. This bit is to be ignored by the decoder but may be exploited by the reproduction system.

- '0' audio programme mixed for a large listening room
- '1' audio programme mixed for a small listening room

**dematrix\_procedure** - Two bits to indicate which dematrix procedure has to be applied in the decoder. The `dematrix_procedure` affects the `tc_allocation` decoding and the denormalisation procedure. For the procedures see subclause 2.5.3.2.1 and 2.5.3.6

- '00' procedure 0
- '01' procedure 1
- '10' procedure 2
- '11' procedure 3

The value '10' can only occur in combination with a 3/1 or 3/2 configuration.

**no\_of\_multi\_lingual\_ch** - An unsigned integer of three bits to indicate the number of multilingual or commentary channels in the mc\_extension bit stream.

**multi\_lingual\_fs** - One bit to indicate whether the sampling frequencies of the multilingual and the main audio channels are the same or not. Equals '1' if the sampling frequency of the multilingual channels is chosen to be  $1/2 * F_s$  (main audio channels), '0' if both sampling frequencies are the same.

**multi\_lingual\_layer** - One bit to indicate whether Layer II ml or Layer III ml is used. With Layer I, Layer II ml is always used.

ISO 11172-3 basic stereo	multi_lingual_layer	Layer
Layer I	X	Layer II ml
Layer II	0	Layer II ml
Layer II	1	Layer III ml
Layer III	0	Layer II ml
Layer III	1	Layer III ml

**copyright\_identification\_bit** - One bit which is part of a 72-bit copyright identification field. The start is indicated by the copyright\_identification\_start bit. The field consists of an 8-bit copyright\_identifier, followed by a 64-bit copyright\_number. The copyright identifier indicates a Registration Authority as designated by SC29. The copyright\_number is a value obtained from this Registration Authority which identifies the copyrighted material.

**copyright\_identification\_start** - One bit to indicate that the copyright\_identification\_bit in this frame is the first bit of the 72-bit copyright identification. If no copyright identification is transmitted, this bit should be kept '0'.

'0' no start of copyright identification in this frame

'1' start of copyright identification in this frame

### 2.5.2.9 MC Error Check

**mc\_crc\_check** - Mandatory 16 bits check word for error detection. Also used to detect whether multichannel or multilingual information is available. In Layer I and II, the calculation begins with the first bit of the multichannel header and ends with the last bit of the scfsi field, but excluding the mc\_crc\_check field itself.

In Layer III, the calculation begins with the first bit of the multichannel header and ends with the last bit of ML\_header() (including).

### 2.5.2.10 MC Composite Status Info Layer I, II

**tc\_sbgr\_select** - One bit indicating whether the tc\_allocation is valid for all subbands or for individual subband groups. Equals '1' if valid for all subbands, '0' if tc\_allocation is valid for individual subband groups. The following table shows the assignment of subbands to the subband groups sbgr.

sbgr	subbands included in the subband group
0	0
1	1
2	2
3	3
4	4
5	5

6	6
7	7
8	8...9
9	10...11
10	12...15
11	16...31

**dyn\_cross\_on** - One bit indicating whether dynamic crosstalk is used. Equals '1' if dynamic crosstalk is used, '0' otherwise.

**mc\_prediction\_on** - One bit indicating whether mc\_prediction is used. Equals '1' if mc\_prediction is used, '0' otherwise.

**tc\_allocation, tc\_allocation[sbgr]** - Contains information on the transmission channel allocation for all subbands or for the subbands in subband group sbgr, respectively. T0 always contains Lo, and T1 always contains Ro. The case of dematrix\_procedure equals '11' implies tc\_allocation[sbgr]==0. If dematrix\_procedure=='10', only tc\_allocations 0, 1, 2 are valid. If Phantom coding is used (centre=='11'), the centre channel must be contained in the additional transmission channels for the subband groups involved, i.e. for those subband groups the value of tc\_allocation must be limited to

0,3,4,5 in 3/2 mode,  
 0,3,4 in 3/1 mode,  
 0 in 3/0 and 3/0 + 2/0 mode.

A) 3/2 configuration (nmch==3):

tc_allocation	T2	T3	T4
0	C <sup>w</sup>	LS <sup>w</sup>	RS <sup>w</sup>
1	L <sup>w</sup>	LS <sup>w</sup>	RS <sup>w</sup>
2	R <sup>w</sup>	LS <sup>w</sup>	RS <sup>w</sup>
3	C <sup>w</sup>	L <sup>w</sup>	RS <sup>w</sup>
4	C <sup>w</sup>	LS <sup>w</sup>	R <sup>w</sup>
5	C <sup>w</sup>	L <sup>w</sup>	R <sup>w</sup>
6	R <sup>w</sup>	L <sup>w</sup>	RS <sup>w</sup>
7	L <sup>w</sup>	LS <sup>w</sup>	R <sup>w</sup>

B) 3/1 configuration (nmch==2):

tc_allocation	T2	T3
0	C <sup>w</sup>	S <sup>w</sup>
1	L <sup>w</sup>	S <sup>w</sup>
2	R <sup>w</sup>	S <sup>w</sup>
3	C <sup>w</sup>	L <sup>w</sup>
4	C <sup>w</sup>	R <sup>w</sup>

C) 3/0 (+ 2/0) configuration (nmch==1 in 3/0 mode, nmch==3 in 3/0+2/0 mode):

tc_allocation	T2
0	C <sup>w</sup>
1	L <sup>w</sup>
2	R <sup>w</sup>

In the case of a second stereo programme, T3 contains L2 and T4 contains R2 of the second stereo programme

D) 2/2 configuration (nmch==2):

tc_allocation	T2	T3
0	LS <sup>W</sup>	RS <sup>W</sup>
1	L <sup>W</sup>	RS <sup>W</sup>
2	LS <sup>W</sup>	R <sup>W</sup>
3	L <sup>W</sup>	R <sup>W</sup>

E) 2/1 configuration (nmch==1):

tc_allocation	T2
0	S <sup>W</sup>
1	L <sup>W</sup>
2	R <sup>W</sup>

F) 2/0 (+ 2/0) configuration (nmch==0 in 2/0 mode, nmch==2 in 2/0+2/0 mode):

In the case of a second stereo programme, T2 contains L2 and T3 contains R2 of the second stereo programme.

G) 1/0 (+ 2/0) configuration (nmch==0 in 1/0 mode, nmch==2 in 1/0+2/0 mode):

In the case of a second stereo programme, T1 contains L2 and T2 contains R2 of the second stereo programme.

**dyn\_cross\_LR** - One bit indicating whether C<sup>W</sup> and/or S<sup>W</sup> shall be copied from Lo (dyn\_cross\_LR=='0'), or from Ro (dyn\_cross\_LR=='1').

**dyn\_cross\_mode[sbgr]** - One to four bits, indicating between which transmission channels dynamic crosstalk is active for the subbands in subband group sbgr. For those subbands, the bit allocation and subband samples are missing in the bit stream. The number of bits of this field depends on the channel configuration which can be either 3/2 (A), 3/1 (B), 3/0 (C), 2/2 (D) and 2/1 (E). The following tables give the missing transmission channels for all modes. If a transmission channel Tj is missing (indicated by a '-' in the tables), the requantised but not yet re-scaled subband samples for the corresponding audio channel have to be copied according to the following rules:

- if there is a term Tij in the same row of the table, the subband samples in transmission channel j have to be copied from transmission channel i.
- if there is a term Tijk in the same row of the table, the subband samples in transmission channels j and k have to be copied from transmission channel i.
- else,
  - L<sup>W</sup> and LS<sup>W</sup> shall be copied from Lo,
  - R<sup>W</sup> and RS<sup>W</sup> shall be copied from Ro,
  - C<sup>W</sup> and S<sup>W</sup> shall be copied from Lo if dyn\_cross\_LR=='0', or from Ro if dyn\_cross\_LR=='1'.

Initially, for all subbands of all transmission channels, the variable dyn\_cross[Tx,sb] has to be set to false. Then, for subbands of transmission channels of which the bit allocation and samples are not transmitted, the variable dyn\_cross[mch,sb] must be set to true:

```
for ( sb = lim1; sb <= lim2; sb++)
    dyn_cross[Tx, sb] = true;
```

where lim1 and lim2 stand for the subband group bounds. The bit allocation of subbands for which dyn\_cross[Tx,sb] is true, has to be copied from the corresponding transmission channel. If that allocation is zero, the scalefactor select information and the scalefactors are not transmitted.

A) 3/2 configuration, field length 4 bits :

dyn_cross_mode[sbgr]	transmission channel		
	T2	T3	T4
0	T2	T3	T4
1	T2	T3	-
2	T2	-	T4
3	-	T3	T4

{ No dynamic crosstalk }



4	T2	–	–
5	–	T3	–
6	–	–	T4
7	–	–	–
8	T2	T34	–
9	T23	-	T4
10	T24	T3	–
11	T23	–	–
12	T24	–	–
13	–	T34	–
14	T234	–	–
15	forbidden		

B) 3/1 configuration, field length 3 bits :

dyn_cross_mode[sbgr]	transmission channel		
0	T2	T3	{ No dynamic crosstalk }
1	T2	–	
2	–	T3	
3	–	–	
4	T23	–	
5	forbidden		
6	forbidden		
7	forbidden		

C) 3/0 configuration, field length 1 bit :

dyn_cross_mode[sbgr]	transmission channel	
0	T2	{ No dynamic crosstalk }
1	–	

D) 2/2 configuration, field length 3 bits :

dyn_cross_mode[sbgr]	transmission channel		
0	T2	T3	{ No dynamic crosstalk }
1	T2	–	
2	–	T3	
3	–	–	
4	T23	–	
5	forbidden		
6	forbidden		
7	forbidden		

E) 2/1 configuration, field length 1 bit :

dyn_cross_mode[sbgr]	transmission channel	
0	T2	{ No dynamic crosstalk }
1	–	

**dyn\_second\_stereo[sbgr]** - One bit indicating whether dynamic cross-talk is used in the second stereo programme. Equals '0' if there is no dynamic crosstalk used in the second stereo programme. If it is '1', subband samples of R2 (Transmission channel T3 in 2/0 + 2/0 configuration, T4 in 3/0 + 2/0 configuration) are copied from L2 (transmission channel T2 in 2/0 + 2/0 configuration, T3 in 3/0 + 2/0 configuration).

**mc\_prediction[sbgr]** - One bit indicating whether or not multichannel redundancy reduction by prediction is used in subband group sbgr. The use of mc\_prediction is limited to subband groups 0 to 7. Equals '1', if redundancy reduction is used, '0', if no redundancy reduction is used.

**predsi[sbgr,px]** - Predictor select information. This indicates whether the predictor indexed by px in subband group sbgr is used and if yes, how many coefficients are transferred.

00	predictor is not used
01	1 coefficient is transferred
10	2 coefficients are transferred
11	3 coefficients are transferred

The maximum number of used predictors npred depends on the dynamic crosstalk (dyn\_cross\_mode). The values of npred are as follows:

configuration	dynamic crosstalk															
	0	1	2	3	4	5	6	7	8	9	10	11	12	13	14	15
3/2	6	4	4	4	2	2	2	0	4	4	4	2	2	2	2	-
3/1	4	2	2	0	2	-	-	-								
3/0	2	0														
2/2	4	2	2	0	2	-	-	-								
2/1	2	0														

### 2.5.2.11 MC Composite Status Information Layer III

**mc\_data\_begin** - 11 bits indicating the negative offset in bytes from the first byte of the actual frame. The number of bytes belonging to the MPEG-1 part of the frame, the mc\_header, mc\_error\_check and mc\_composite\_status\_info is not taken into account. This means if mc\_data\_begin == 0, the mc\_main\_data starts after the last byte\_aligned\_bit.

**seg\_list\_present[gr][ch]** - Is only transmitted if the channel is flagged as present in mc\_header(). If seg\_list\_present is not flagged ( which is only legal for at maximum two channels ), the respective channel is reconstructed by dematrixing of the left/right compatible and the transmitted channels.

**seg\_list\_nodef[gr][ch]** - Indicates if the segment list is transmitted or if the default is used. The default segment list indicates that the channel is transmitted completely in the specified channel.

**segment\_list\_repeat[ch]** - Indicates if the segment list of the second granule is identical to the segment list of the first one. This variable is only transmitted if the segment list of the first granule is transmitted is not the default type.

**tc\_present[gr][ch]** - Indicates whether information about a tc (transmitted channel) can be found in the bit stream. The difference between seg\_list\_present and tc\_present is that there can be fewer transmitted channels than output channels even if considering channels which are reconstructed by dematrixing. A channel which does have a segment list, but no corresponding tc must be reconstructed via intensity stereo. A channel which has tc\_present set can be referenced by tc\_select. tc\_present ==1 means the channel is present. For audio channels which are flagged in the mc\_header() as not present, a tc\_present value of zero is assumed.

ch\_present(ch) - Is a function indicating whether audio channel ch is present, as indicated in mc\_header().

**block\_type[gr][ch]** - Indicates the window type for the granule/channel (see description of the filterbank, Layer III).

block_type[gr]	window type
0	normal block
1	start block
2	3 short windows
3	end block

block\_type gives the information about assembling of values in the block and about length and count of the transforms (see figure A.4 for a schematic, annex C for an analytic description). The polyphase filterbank is described in ISO/IEC 11172-3 subclause 2.4.3.

In the case of long blocks (block\_type not equal to 2), the IMDCT generates an output of 36 values for every 18 input values. The output is windowed depending on the block\_type, and the first half is overlapped with the second half of the preceding block. The resulting vector is the input of the synthesis part of the polyphase filterbank of one band.

In the case of short blocks (block\_type is 2), three transforms are performed producing 12 output values each. The three vectors are windowed and overlapped. Concatenating 6 zeros on both ends of the resulting vector gives a vector of length 36, which is processed like the output of a long transform.

If block\_type is not zero, several other variables are set by default:

region0\_count = 7 (in case of block\_type==1 or block\_type==3)

region0\_count = 8 (in case of block\_type==2)

region1\_count = 36 Thus all remaining values in the big\_value region are contained in region 1.

**dematrix\_length** - Number of scalefactorband\_groups where the dematrixed channels are explicitly transmitted. The first dematrix\_length scalefactorband\_groups have no joint stereo information (tc\_select) transmitted. If dematrix\_length == 0, the channels to be reconstructed by dematrixing are determined by seg\_list\_present.

**dematrix\_select[sbgr]** - Information given for the first dematrix\_length scalefactorband\_groups. It tells which of the output channels should be reconstructed by dematrixing using the formula of the compatibility matrix. The following table shows the mapping of transmitted value in dematrix\_select to the channels which have to be reconstructed by dematrixing. x means that this channel has to be reconstructed by dematrixing and '0' means no dematrixing of this channel.

3/2, 3/1 and 2/2 configuration (4 bits)

dematrix_select:	L	R	C	LS / S	RS	valid in 3/2	valid in 3/1	valid in 2/2
0	0	0	0	0	0	y	y	y
1	x	0	0	0	0	y	y	y
2	0	x	0	0	0	y	y	y
3	x	x	0	0	0	y	y	y
4	0	0	x	0	0	y	y	n
5	x	0	x	0	0	y	y	n
6	0	x	x	0	0	y	y	n
7	0	0	0	x	0	y	y	y

8	0	x	0	x	0	y	y	y
9	0	0	x	x	0	y	n	n
10	0	0	0	0	x	y	n	y
11	x	0	0	0	x	y	n	y
12	0	0	x	0	x	y	n	n
13	0	0	0	x	x	y	n	y
14	x	0	0	x	0	n	y	n
15	-	-	-	-	-	n	n	n

3/0 and 2/1 configuration (3 bits)

dematrix_select:	L	R	C / S	valid in 3/0	valid in 2/1
0	0	0	0	y	y
1	x	0	0	y	y
2	x	x	0	y	y
3	0	0	x	y	y
4	x	0	x	y	y
5	0	x	x	y	y
6	-	-	-	n	n
7	-	-	-	n	n

scalefactorband\_group - For transmitting of the dematrix\_length and the segment list, the scalefactorbands are grouped together. The following two tables show the grouping for long ( block\_type == 0, 1, 3 ) and short blocks ( block\_type == 2 ). For short blocks the scalefactorband\_group includes the respective values of all three subblocks.

Width and begin of each scalefactorband\_group (sbgr) in scalefactorbands:

sbgr #	Long blocks ( block_type == 0, 1, 3 )		Short block ( block_type == 2 )	
	sbgr width	sbgr begin	sbgr width	sbgr begin
0	3	0	1	0
1	3	3	1	1
2	3	6	1	2
3	1	9	1	3
4	1	10	1	4
5	1	11	1	5
6	1	12	1	6
7	1	13	1	7
8	1	14	1	8
9	1	15	1	9
10	1	16	1	10
11	1	17	2	11
12	1	18	-	13
13	1	19	-	-
14	2	20	-	-
15	-	22	-	-

attenuation\_range[gr][ch] - The attenuation of the segment list has four different ranges. The following table indicates the range of the attenuation:

attenuation_range:	number of bits for attenuation
0	2
1	3
2	4
3	5

**attenuation\_scale[gr][ch]** - Determines the attenuation step size. For `attenuation_scale == 0`, the step size is  $1/\sqrt[3]{2}$ . For `attenuation_scale == 1`, the step size is  $1/\sqrt{2}$ .

**seg\_length[gr][ch][seg]** - Is the number of scalefactorband groups which are multiplied with attenuation from `tc_select` and are copied into the channel (ch). `Seg_length == 0` stops the transmitting of `tc_select` and attenuation immediately. The not selected `scalefactorband_groups` are set to zero.

**tc\_select[gr][ch][seg]** - Indicates the number of the transmitted channel which is the source for segment list processing. `tc_select == 7` indicates that the values in this segment are reconstructed by dematrixing.

**attenuation[gr][ch][seg][sbgr]** - For each `scalefactorband_group`, one attenuation is transmitted to assemble the channel. The width of attenuation can vary from 2 to 5 bits. This is indicated by `attenuation_range`. The step size of attenuation is determined by `attenuation_scale` and can vary between  $\sqrt{2}$  and  $\sqrt[3]{2}$ . If `tc_select == 7`, this means dematrixing of the channel and no attenuations are transmitted. If `tc_select == ch`, this means that the transmitted channel is the selected channel and no attenuations are transmitted.

**mc\_prediction\_on** - One bit indicating whether `mc_prediction` is used. Equals '1' if `mc_prediction` is used, '0' if not.

**mc\_prediction[sbgr]** - One bit indicating whether or not multichannel redundancy reduction by prediction is used in subband group `sbgr`. Equals '1', if redundancy reduction is used '0', if no redundancy reduction is used.

**predsi[sbgr,pci]** - Predictor select information, indicating whether the predictor coefficient indexed by `pci` in subband group `sbgr` is transferred. Equals '1' if coefficient is transmitted, '0' otherwise.

**pred\_coef[sbgr,pci]** - Actual prediction coefficient used for the subbands in subband group `sbgr` and index `pci`.

### 2.5.2.12 MC Audio Data Layer I, II

**lfe\_allocation** - Contains information on the quantiser used for the samples in the low frequency enhancement channel. The bits in this field form an unsigned integer used as an index (for subband 0) to the relevant table in Table B.2 "Layer II bit allocation table" of ISO/IEC 11172-3, which gives the number of levels used for quantisation. Table B.2.a of ISO/IEC 11172-3 shall be used if `Fs` equals 48 kHz, table B.2.b of ISO/IEC 11172-3 shall be used if `Fs` equals 44,1 kHz or 32 kHz, regardless of the bitrate.

**allocation[mch,sb]** - Contains information on the quantiser used for the samples in subband `sb` of the multichannel extension channel `mch`. Whether this allocation field exists for a certain subband and channel depends on the `composite_status_info`. The bits in this field form an unsigned integer used as an index to the relevant table in Table B.2 "Layer II bit allocation table" of ISO/IEC 11172-3, which gives the number of levels used for quantisation. Table B.2.a shall be used if `Fs` equals 48 kHz, table B.2.b shall be used if `Fs` equals 44,1 kHz or 32 kHz, regardless of the bitrate. The value of `msblimit` should be set to `sblimit` of the relevant table.

**scfsi[mch,sb]** - Scalefactor select information, indicating the number of scalefactors transferred for subband `sb` of the multichannel extension channel `mch`. The frame is divided into three equal parts of 12 subband samples each per subband.

- '00' three scalefactors transmitted, for parts 0,1,2 respectively.
- '01' two scalefactors transmitted, first one valid for parts 0 and 1, second one for part 2.
- '10' one scalefactor transmitted, valid for all three parts.
- '11' two scalefactors transmitted, first one valid for part 0, second one for parts 1 and 2.

**delay\_comp[sbgr,px]** - Three bits specifying a shift of 0, 1, 2, ..., 7 subband samples for delay compensation in subband group `sbgr` and predictor index `px`.

**pred\_coef[sbgr,px,pci]** - Actual coefficient of predictor with up to second order in subband group sbgr and predictor index px.

**lf\_scalefactor** - Indicates the factor by which the requantised samples of the low frequency enhancement channel should be multiplied. The six bits constitute an unsigned integer, index to table B.1 "Layer I, II scalefactors" of ISO/IEC 11172-3.

**scalefactor[mch,sb,p]** - Indicates the factor by which the requantised samples of subband sb of part p of the frame of multichannel extension channel mch should be multiplied. The six bits constitute an unsigned integer, index to table B.1 "Layer I, II scalefactors" of ISO/IEC 11172-3.

**lf\_sample[gr]** - Coded representation of the single sample in granule gr of the low frequency enhancement channel.

**samplecode[mch,sb,gr]** - Coded representation of three consecutive samples in granule gr of subband sb of multichannel extension channel mch.

**sample[mch,sb,s]** - Coded representation of the sample s of subband sb of multichannel extension channel mch.

### 2.5.2.13 MC Audio Data Layer III

**data\_present[gr][tc][sfb]** - Is a map describing which data (dependent on granule, transmitted channel and scalefactorband) are actually transmitted. This map is not transmitted but recovered in the decoder by determining the scalefactorbands which are referenced by dematrix\_select or the segment\_lists.

**js\_carrier[gr][tc][sbgr]** - Is a map describing which scalefactorband\_group data (dependent on granule, transmitted channel and scalefactorband\_group) are used as a carrier for joint stereo transmission. This map is not transmitted but recovered in the decoder by determining the scalefactorband\_groups which are referenced with a tc\_select != ch.

**matrix\_attenuation\_present** - Denotes whether or not the matrix\_attenuation is transmitted.

matrix\_attenuation\_present equals 1 if matrix\_attenuation is transmitted

**matrix\_attenuation\_l/r[gr][ch][sbgr]** - In the case of joint stereo coding, correction values are needed to get energy preservation in the compatible downmixed signals Lo and Ro. In the decoder an attenuation is applied to get correct dematrixing.

The actual attenuation factors are calculated as:

$$\text{attenuation} = 1 / (\sqrt{2} ** \text{matrix\_attenuation\_l/r})$$

For the dematrixing using the Lo (Ro) channel, matrix\_attenuation\_l (matrix\_attenuation\_r) is used. The modification of the dematrixing operation is described in the decoding process.

**scfsi[tc][scfsi\_band]** - In Layer III, the scalefactor selection information works similarly to audio Layer II. The main difference is the use of the variable scfsi\_band to apply scfsi to groups of scalefactors instead of single scalefactors. The application of scalefactors to granules is controlled by scfsi. The scalefactor selection information is only transmitted if the channel is transmitted in both granules. The others are set to zero.

scfsi[scfsi_band]	
'0'	scalefactors are transmitted for each granule
'1'	scalefactors transmitted for granule 0 are also valid for granule 1

If short windows are switched on, i.e. block\_type==2 for one of the granules, then scfsi is always 0 for this frame.

**scfsi\_band** - Controls the use of the scalefactor selection information for groups of scalefactors (scfsi\_bands).

scfsi_band	scalefactor bands (see table B.8)
0	0,1,2,3,4,5,
1	6,7,8,9,10,
2	11 ... 15
3	16 ... 20

**part2\_3\_length[gr][tc]** - Contains the number of main\_data bits used for scalefactors and Huffman code data.

**big\_values[gr][tc]** - The spectral values of each granule are coded with different Huffman code tables. The full frequency range from zero to the Nyquist frequency is divided into several regions which are coded using different tables. Partitioning is done according to the maximum quantised values. This is done with the assumption that values at higher frequencies are expected to have lower amplitudes or do not need to be coded at all. Starting at high frequencies, the pairs of quantised values equal to zero are counted. This number is named "rzero". Then, quadruples of quantised values with absolute value not exceeding 1 (i.e. only 3 possible quantisation levels) are counted. This number is named "count1". Again, an even number of values remain. Finally, the number of pairs of values in the region of the spectrum which extends down to zero is named "big\_values". The maximum absolute value in this range is constrained to 8191. The following figure shows the partitioning:

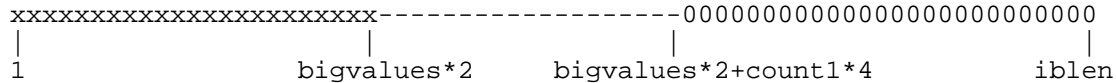

The values 000 are all zero. Their number is a multiple of 2.  
 The values --- are -1, 0 or +1. Their number is a multiple of 4.  
 The values xxx are not bound. Their number is a multiple of 2.  
 iblen is 576.

**global\_gain[gr][tc]** - The quantiser step size information is transmitted in the side information variable global\_gain. It is logarithmically quantised. For the application of global\_gain, refer to the formula in ISO/IEC 11172-3 subclause 2.4.3.4, "Formula for requantisation and all scaling".

**scalefac\_compress[gr][tc]** - Selects the number of bits used for the transmission of the scalefactors according to the following table:

if block\_type is 0, 1, or 3:  
     slen1: length of scalefactors for the scalefactor bands 0 to 10  
     slen2: length of scalefactors for the scalefactor bands 11 to 20

if block\_type is 2:  
     slen1: length of scalefactors for the scalefactor bands 0 to 5  
     slen2: length of scalefactors for the scalefactor bands 6 to 11

scalefac_compress[gr]	slen1	slen2
0	0	0
1	0	1
2	0	2
3	0	3
4	3	0
5	1	1
6	1	2
7	1	3
8	2	1
9	2	2
10	2	3
11	3	1
12	3	2
13	3	3
14	4	2
15	4	3

**table\_select[gr][tc][region]** - Different Huffman code tables are used depending on the maximum quantised value and the local statistics of the signal. There are a total of 32 possible tables given in table B.7.

**subblock\_gain[gr][tc][window]** - Indicates the gain offset (quantisation: factor 4) from the global gain for one subblock. Transmitted only with block type 2 (short windows). The values of the subblock have to be divided by 4 (subblock\_gain[window]) in the decoder. See ISO/IEC 11172-3 subclause 2.4.3.4 - Formula for requantisation and all scaling.

**region0\_count[gr][tc]** - A further partitioning of the spectrum is used to enhance the performance of the Huffman coder. This partitioning is a subdivision of the region which is described by big\_values. The purpose of this subdivision is to get improved error robustness and improved coding efficiency. Three regions are used, they are named region 0, 1 and 2. Each region is coded using a different Huffman code table depending on the maximum quantised value and the local signal statistics.

The values region0\_count and region1\_count are used to indicate the boundaries of the regions. The region boundaries are aligned with the partitioning of the spectrum into scale factor bands.

The field region0\_count contains one less than the number of scalefactor bands in region 0. In the case of short blocks, each scale factor band is counted three times, once for each short window, so that a region0\_count value of 8 indicates that region1 begins at scalefactor band number 3.

If block\_type==2, the total amount of scalefactor bands for the granule in this case is 12\*3=36. If block\_type!=2, the amount of scalefactor bands is 21.

**region1\_count[gr][tc]** - Region1\_count counts one less than the number of scalefactor bands in region 1. Again, if block\_type==2 the scalefactor bands representing different time slots are counted separately.

**preflag[gr][tc]** - This is a shortcut for additional high frequency amplification of the quantised values. If preflag is set, the values of a table are added to the scalefactors (see table B.6). This is equivalent to multiplication of the requantised scalefactors with table values. If block\_type==2 (short blocks) preflag is never used.

**scalefac\_scale[gr][tc]** - The scalefactors are logarithmically quantised with a step size of 2 or  $\sqrt{2}$  depending on scalefac\_scale. The following table indicates the scale factor multiplier used in the requantisation equation for each stepsize.

scalefac_scale[gr]	scalefac_multiplier
0	0,5
1	1

**count1table\_select[gr][tc]** - This flag selects one of two possible Huffman code tables for the region of quadruples of quantised values with magnitude not exceeding 1.

count1table_select[gr]	
0	Table B.7 - A
1	Table B.7 - B

**scalefac\_l[gr][tc][sfb], scalefac\_s[gr][tc][sfb][window], is\_pos[sfb]** - The scalefactors are used to colour the quantisation noise. If the quantisation noise is coloured with the right shape, it is masked completely. Unlike Layers I and II, the Layer III scalefactors say nothing about the local maximum of the quantised signal. In Layer III, scalefactors are used in the decoder to get division factors for groups of values. In the case of Layer III, the groups stretch over several frequency lines. These groups are called scalefactor bands and are selected to resemble critical bands as closely as possible.

The scalefac\_compress table shows that the scalefactors 0...10 have a range of 0 to 15 (maximum length 4 bits) and that scalefactors 11...21 have a range of 0 to 7 (maximum length 3 bits).

The subdivision of the spectrum into scalefactor bands is fixed for every block length and sampling frequency and stored in tables in the coder and decoder (see table B.8). The scale factor for frequency lines above the highest line in the tables is zero, which means that the actual multiplication factor is 1,0.

The scalefactors are logarithmically quantised. The quantisation step is set with scalefac\_scale.



Scalefactors of scalefactorbands which are not selected by a transmitted channel are not transmitted. This means the scalefactors will be packed together for transmission and have to be unpacked for decoding or dematrixing.

**byte\_align\_bit** - Private bits used to do a byte alignment of the mc\_main\_data.

**huffmancodebits()** - Huffman encoded data.

The syntax for huffmancodebits() shows how quantised values are encoded. Within the big\_values partition, pairs of quantised values with an absolute value less than 15 are directly coded using a Huffman code. The codes are selected from Huffman tables 0 through 31 in table B.7. Values (x,y) are always coded in pairs. If quantised values of magnitude greater than or equal to 15 are coded, these values are coded with a separate field following the Huffman code. If one or both values of a pair are not zero, one or two sign bits are appended to the code word.

The Huffman tables for the big\_values partition are comprised of three parameters:

hcod[|x|][|y|] is the Huffman code table entry for values x,y.  
 hlen[|x|][|y|] is the Huffman length table entry for values x,y.  
 linbits is the length of linbitsx or linbitsy when they are coded.

The syntax for huffmancodebits contains the following fields and parameters:

signv is the sign of v (0 if positive, 1 if negative).  
 signw is the sign of w (0 if positive, 1 if negative).  
 signx is the sign of x (0 if positive, 1 if negative).  
 signy is the sign of y (0 if positive, 1 if negative).  
 linbitsx is used to encode the value of x if the magnitude of x is greater or equal to 15. This field is coded only if |x| in hcod is equal to 15. If linbits is zero, so that no bits are actually coded when |x|=15, then the value linbitsx is defined to be zero.  
 linbitsy is the same as linbitsx but for y.  
 is[l] Is the quantised value for frequency line number l.

The linbitsx or linbitsy fields are only used if a value greater or equal to 15 needs to be encoded. These fields are interpreted as unsigned integers and added to 15 to obtain the encoded value. The linbitsx and linbitsy fields are never used if the selected table is one for blocks with a maximum quantised value less than 15. Note that a value of 15 can still be encoded with a Huffman table for which linbits is zero. In this case, the linbitsx or linbitsy fields are not actually coded, since linbits is zero.

Within the count1 partition, quadruples of values with magnitude less than or equal to one are coded. Magnitude values are coded using a Huffman code from tables A or B in table B.7. For each non-zero value, a sign bit is appended after the Huffman code symbol.

The Huffman tables for the count1 partition are comprised of the following parameters:

hcod[|v|][|w|][|x|][|y|] is the Huffman code table entry for values v,w,x,y.  
 hlen[|v|][|w|][|x|][|y|] is the Huffman length table entry for values v,w,x,y.

Huffman code table B is not really a 4-dimensional code because it is constructed from a trivial code: 0 is coded with a 1, and 1 is coded with a 0.

Quantised values above the count1 partition are zero, so they are not encoded.

For clarity, the parameter "count1" is used in this document to indicate the number of Huffman codes in the count1 region. However, unlike the bigvalues partition, the number of values in the count1 partition is not explicitly coded by a field in the syntax. The end of the count1 partition is known only when all bits for the granule (as specified by part2\_3\_length), have been exhausted, and the value of count1 is known explicitly after decoding the count1 region.

The order of the Huffman data depends on the block\_type of the granule. If block\_type is 0, 1 or 3, the Huffman encoded data is ordered in terms of increasing frequency.

If block\_type==2 (short blocks) the Huffman encoded data is ordered in the same order as the scalefactor values for that granule. The Huffman encoded data is given for successive scalefactor bands, beginning with scalefactor band 0.

Within each scalefactor band, the data is given for successive time windows, beginning with window 0 and ending with window 2. Within each window, the quantised values are then arranged in order of increasing frequency.

**lfe\_table\_select** - Determines the Huffman code table that is used to decode the spectral values of the low frequency enhancement channel. The interpretation is the same as for table\_select.

**lfe\_hc\_len** - Determines the total length of the Huffman coded spectral values of the low frequency enhancement channel for both granules.

**lfe\_gain** - Determines the quantiser step size of the low frequency enhancement channel. The interpretation is the same as for global\_gain.

**lfe\_main\_data()** - Contains the Huffman coded spectral values for the low frequency enhancement channel in both granules. lfe\_main\_data() is interpreted just like a Huffmancodebits() structure that consists of big\_values and zero\_values only. Similarly to count1 in Huffmancodebits, the number of Huffman codes in lfe\_main\_data() (i.e. lfe\_bigval) is not transmitted explicitly. Instead, it is recovered by Huffman decoding until all bits indicated in lfe\_hc\_len have been exhausted. Unlike the Huffmancodebits() structure, the decoded values x and y denote the values of a spectral coefficient for granule 0 and 1 respectively.

#### 2.5.2.14 ML Audio Data Layer I and Layer II

**allocation[mlch,sb]** - Contains information on the quantiser used for the samples in subband sb of the multilingual extension channel mlch. The bits in this field form an unsigned integer used as an index to the relevant table in Table B.2 "Layer II bit allocation table" of ISO/IEC 11172-3, which gives the number of levels used for quantisation. Table B.2.a shall be used if Fs equals 48 kHz, table B.2.b shall be used if Fs equals 44,1 kHz or 32 kHz, regardless of the bitrate. If the half sampling frequency is used for the multilingual channels (multi\_lingual\_fs==1), table B.1 of this Recommendation | International Standard shall be used. The value of mlsblimit should be set to sblimit of the relevant table.

**scfsi[mlch,sb]** - Scalefactor select information, indicating the number of scalefactors transferred for subband sb of the multilingual extension channel mlch. The frame is divided into three equal parts of 12 (if multi\_lingual\_fs equals '0', full sampling frequency) or 6 (if multi\_lingual\_fs equals '1', half sampling frequency) subband samples each per subband.

- '00' three scalefactors transmitted, for parts 0,1,2 respectively.
- '01' two scalefactors transmitted, first one valid for parts 0 and 1, second one for part 2.
- '10' one scalefactor transmitted, valid for all three parts.
- '11' two scalefactors transmitted, first one valid for part 0, second one for parts 1 and 2.

**scalefactor[mlch,sb,p]** - Indicates the factor by which the requantised samples of subband sb of part p of the frame of multilingual extension channel mlch should be multiplied. The six bits constitute an unsigned integer, index to table B.1 "Layer I, II scalefactors" of ISO/IEC 11172-3.

**samplecode[mlch,sb,gr]** - Coded representation of three consecutive samples in granule gr of subband sb of multilingual extension channel mlch. The number of granules ngr equals 12 if multi\_lingual\_fs equals '0' (full sampling frequency) and equals 6 if multi\_lingual\_fs equals '1' (half sampling frequency).

**sample[mlch,sb,s]** - Coded representation of the sample s of subband sb of multilingual extension channel mlch.

#### 2.5.2.15 ML Audio Data Layer III

See ISO/IEC 11172-3, subclause 2.4.2.7, or this Recommendation | International Standard, subclause 2.4.2.7, depending on **mult\_lingual\_fs**.

#### 2.5.2.16 MPEG-1 Ancillary Data

see ISO/IEC 11172-3, subclause 2.4.2.8

### 2.5.2.17 Extension frame

**ext\_header** - part of the extension bit stream containing synchronisation and state information.

**ext\_data** - part of the multichannel/multilingual field in the bit stream that contains those bits that cannot be transmitted in the MPEG-1 compatible part of the bit stream.

**ext\_ancillary\_data** - Part of the extension bit stream that can be used for carrying ancillary data.

### 2.5.2.18 Extension header

**ext\_syncword** - A 12 bit string '0111 1111 1111', to synchronize the MPEG-1-compatible bit stream and the extension bit stream.

**ext\_crc\_check** - Mandatory 16 bit check word. The calculation of the CRC-check begins with the first bit of the ext\_length field. The number of bits included in the CRC check equals 128, or less if the end of the ext\_data field is reached earlier.

**ext\_length** - 11 bit number, indicating the total number of bytes in the extension frame.

**ext\_ID\_bit** - Reserved for future use. Should be set to '0' for an ISO/IEC 13818-3 extension bit stream.

## 2.5.3 The Audio Decoding Process

### 2.5.3.1 General

The general decoding process closely resembles ISO/IEC 11172-3, subclause 2.4.3. This includes bit allocation decoding, scalefactor select info decoding, scalefactor decoding, requantisation of subband samples in case of Layer I or II, and side information decoding, scalefactor decoding, Huffman decoding, requantisation, reordering, synthesis filterbank and alias reduction in case of Layer III.

The first action is decoding of the backwards compatible signal  $L_0$ ,  $R_0$  according to ISO/IEC 11172-3, subclause 2.4.3. The MPEG-1 ancillary data field is initially assumed to contain the coded multichannel extension signal. If the mandatory CRC-check yields a valid result, then multichannel decoding will be started. Only one out of each three consecutive ISO/IEC 11172-3 Layer I frames contains a multichannel header. The first 16...24 bits of the multichannel extension constitute the multichannel header, providing information on the presence of a centre channel, surround channels, LFE channel, the dematrixing procedure to be followed, the number of multilingual channels contained in the multichannel extension bit stream, the sampling frequency of the multilingual channels, the coding layer which has been applied to the multilingual channels, and a copyright identification.

This Recommendation | International Standard provides the possibility to extend the bit rate beyond the bit rates defined in ISO/IEC 11172-3 for the three Layers, while preserving backwards compatibility with this standard. This is achieved by using an extension bit stream that contains the remainder of the data of the multichannel/multilingual data. The structure of this bit stream is depicted in Figure A.2 of Annex A. Within the MPEG-2 bit stream, the MPEG-1 compatible bit stream contains at least the MPEG-1 Audio Data and MC header.

The error detection method of the mandatory CRC-check word which follows directly the mc\_header is identical to the one used in ISO/IEC 11172-3, and is described in ISO/IEC 11172-3 subclause 2.4.3.1.

**2.5.3.2 Composite Coding Modes**

**2.5.3.2.1 Transmission Channel Switching**

The allocation of the audio channels to the transmission channels (tc\_allocation) can be valid for the whole bandwidth or for individual subband groups depending on the value of tc\_sbgr\_select. The tc\_allocation field determines, depending on the configuration, which audio channels are contained in the transmission channels. For each possibility, a decoding matrix exists that has to be applied in the subband domain to all the transmitted channels in order to obtain the output channels. The matrices are given below. The resulting signals still have to be de-normalised (see subclause 2.5.3.6). If dematrix\_procedure '11' (see subclause 2.5.2.8) is chosen, all signals can be directly derived from the transmission channels, and no dematrixing is needed. In this case the default value tc\_allocation '0' applies. If dematrix\_procedure='10', the following processing is needed on the surround channels:

1. In the 3/2 configuration, calculate the monophonic surround signal:  

$$jS^W = 0,5*(jLS^W + jRS^W);$$
2. The filter described in Table B.3 of Annex B has to be applied to  $jS^W$ .
3. The resulting bandwidth-limited signal  $jS^W_{bp}$  has to be used for the dematrixing.

The following processing may be done on the signals  $jLS^W$  and  $jRS^W$  in the 3/2 configuration or  $jS^W$  in the 3/1 configuration before output (these operations may not be done before dematrixing) :

- 4a -90 degrees phase shift
- 4b Half Dolby® B-type decoding.

**Decoding matrices:**

The following dematrix equations are valid for the different multichannel configurations. The dematrixing equations do not affect a second stereo programme.

3/2 configuration, dematrixing procedure equals '00' and '01':

tc_allocation	decoding matrix
0	$L^W = Lo - T2 - T3$
	$R^W = Ro - T2 - T4$
	$C^W = T2$
	$LS^W = T3$
	$RS^W = T4$

tc_allocation	decoding matrix
1	$C^W = Lo - T2 - T3$
	$R^W = Ro - C^W - T4$
	$L^W = T2$
	$LS^W = T3$
	$RS^W = T4$

tc_allocation	decoding matrix
2	$C^W = Ro - T2 - T4$
	$L^W = Lo - C^W - T3$
	$R^W = T2$
	$LS^W = T3$
	$RS^W = T4$

tc_allocation	decoding matrix
3	$LS^W = Lo - T3 - T2$
	$R^W = Ro - T2 - T4$
	$C^W = T2$
	$L^W = T3$
	$RS^W = T4$

tc_allocation	decoding matrix
4	$L^W = Lo - T2 - T3$
	$RS^W = Ro - T4 - T2$
	$C^W = T2$

tc_allocation	decoding matrix
5	$LS^W = Lo - T3 - T2$
	$RS^W = Ro - T4 - T2$
	$C^W = T2$

	$LS^W = T3$
	$R^W = T4$

	$L^W = T3$
	$R^W = T4$

tc_allocation	decoding matrix
6	$C^W = Ro - T2 - T4$
	$LS^W = Lo - T3 - C^W$
	$R^W = T2$
	$L^W = T3$
	$RS^W = T4$

tc_allocation	decoding matrix
7	$C^W = Lo - T2 - T3$
	$RS^W = Ro - T4 - C^W$
	$L^W = T2$
	$LS^W = T3$
	$R^W = T4$

3/2 configuration, dematrixing procedure equals '10':

tc_allocation	decoding matrix
0	$L^W = Lo - T2 + jS_{bp}^W$
	$R^W = Ro - T2 - jS_{bp}^W$
	$C^W = T2$
	$jLS^W = T3$
	$jRS^W = T4$

tc_allocation	decoding matrix
1	$C^W = Lo - T2 + jS_{bp}^W$
	$R^W = Ro - C^W - jS_{bp}^W$
	$L^W = T2$
	$jLS^W = T3$
	$jRS^W = T4$

tc_allocation	decoding matrix
2	$C^W = Ro - T2 - jS_{bp}^W$
	$L^W = Lo - C^W + jS_{bp}^W$
	$R^W = T2$
	$jLS^W = T3$
	$jRS^W = T4$

3/1 configuration, dematrixing procedure equals '00' and '01

tc_allocation	decoding matrix
0	$L^W = Lo - T2 - T3$
	$R^W = Ro - T2 - T3$
	$C^W = T2$
	$S^W = T3$

tc_allocation	decoding matrix
1	$C^W = Lo - T2 - T3$
	$R^W = Ro - C^W - T3$
	$L^W = T2$
	$S^W = T3$

tc_allocation	decoding matrix
2	$C^W = Ro - T2 - T3$
	$L^W = Lo - C^W - T3$
	$R^W = T2$
	$S^W = T3$

tc_allocation	decoding matrix
3	$S^W = Lo - T2 - T3$
	$R^W = Ro - T2 - S^W$
	$C^W = T2$
	$L^W = T3$

tc_allocation	decoding matrix
4	$S^W = Ro - T2 - T3$
	$L^W = Lo - T2 - S^W$
	$C^W = T2$

	$R^W = T3$
--	------------

3/1 configuration, dematrixing procedure equals '10':

tc_allocation	decoding matrix
0	$L^W = L_o - T2 + jS_{bp}^W$
	$R^W = R_o - T2 - jS_{bp}^W$
	$C^W = T2$
	$jS^W = T3$

tc_allocation	decoding matrix
1	$C^W = L_o - T2 + jS_{bp}^W$
	$R^W = R_o - C^W - jS_{bp}^W$
	$L^W = T2$
	$jS^W = T3$

tc_allocation	decoding matrix
2	$C^W = R_o - T2 - jS_{bp}^W$
	$L^W = L_o - C^W + jS_{bp}^W$
	$R^W = T2$
	$jS^W = T3$

3/0 configuration:

tc_allocation	decoding matrix
0	$L^W = L_o - T2$
	$R^W = R_o - T2$
	$C^W = T2$

tc_allocation	decoding matrix
1	$C^W = L_o - T2$
	$R^W = R_o - C^W$
	$L^W = T2$

tc_allocation	decoding matrix
2	$C^W = R_o - T2$
	$L^W = L_o - C^W$
	$R^W = T2$

2/2 configuration:

tc_allocation	decoding matrix
0	$L^W = L_o - T2$
	$R^W = R_o - T3$
	$LS^W = T2$
	$RS^W = T3$

tc_allocation	decoding matrix
1	$R^W = R_o - T3$
	$LS^W = L_o - T2$
	$L^W = T2$
	$RS^W = T3$

tc_allocation	decoding matrix
2	$L^W = L_o - T2$
	$RS^W = R_o - T3$
	$LS^W = T2$
	$R^W = T3$

tc_allocation	decoding matrix
3	$LS^W = L_o - T2$
	$RS^W = R_o - T3$
	$L^W = T2$
	$R^W = T3$

2/1 configuration:

tc_allocation	decoding matrix
0	$L^W = L_o - T2$
	$R^W = R_o - T2$
	$S^W = T2$

tc_allocation	decoding matrix
1	$S^W = L_o - T2$
	$R^W = R_o - S^W$
	$L^W = T2$

tc_allocation	decoding matrix
2	$S^W = R_o - T2$
	$L^W = L_o - S^W$
	$R^W = T2$

### 2.5.3.2.2 Dynamic Crosstalk

If dynamic crosstalk is enabled for a channel for a certain subband group, i.e.  $\text{dyn\_cross}[Tx, sb]$  is true, the bit allocation for each subband of this subband group, and the coded subband samples are not transmitted. The bit allocation and decoded subband samples shall be copied from the corresponding transmission channel. The 'dyn\_cross\_mode' field in the bit stream indicates from which channel, and to which channel the subband samples have to be copied. The scalefactor select information and the scalefactors which shall be used for the re-scaling of the subband samples are however contained in the bit stream.

The following rules shall apply for the different configurations:

#### 3/2 configuration

If transmission channel T2 is missing, and the corresponding presentation channel is L, this channel is derived by multiplying the subband samples transmitted for  $L_o$  with the scalefactors transmitted in T2. If the missing presentation channel in T2 is C and  $\text{dyn\_cross\_LR}$  is '0', this channel is derived by multiplying the subband samples transmitted for  $L_o$  with the scalefactors transmitted in T2, if  $\text{dyn\_cross\_LR}$  is '1', this channel is derived by multiplying the subband samples transmitted for  $R_o$  with the scalefactors transmitted in T2. If the missing presentation channel is R, this channel is derived by multiplying the subband samples transmitted for  $R_o$  with the scalefactors transmitted in T2. If transmission channel T3 is missing, which contains either L or LS, the presentation channels L or LS are derived by multiplying the subband samples of  $L_o$  with the scalefactors transmitted in T3. If transmission channel T4 is missing, which contains either R or RS, these channels are derived by multiplying the subband samples of  $R_o$  with the scalefactors transmitted in T4. A term  $TS_{ij}$  in the table means that the subband samples in transmission channel j have to be copied from transmission channel i. The input samples for the synthesis filter of transmission channel  $T_i$  are derived by multiplying the subband samples  $TS_{ij}$  by scalefactors  $scf_j$ . The input samples for the synthesis filter of transmission channel  $T_j$  are derived by multiplying the subband samples  $TS_{ij}$  by scalefactors  $scf_j$ . The rest of the decoding is the same as the situation without dynamic crosstalk.

**3/1 configuration**

If transmission channel T2 is missing, and the corresponding presentation channel is L, this channel is derived by multiplying the subband samples transmitted for Lo with the scalefactors transmitted in T2. If the missing presentation channel in T2 is C and dyn\_cross\_LR is '0', this channel is derived by multiplying the subband samples transmitted for Lo with the scalefactors transmitted in T2, if dyn\_cross\_LR is '1', this channel is derived by multiplying the subband samples transmitted for Ro with the scalefactors transmitted in T2. If the missing presentation channel is R, this channel is derived by multiplying the subband samples transmitted for Ro with the scalefactors transmitted in T2. If the missing presentation channel is S, this channel is derived by multiplying the subband samples transmitted for Lo and Ro with the scalefactors transmitted in T2. The same procedure is valid for transmission channel T3 except that the transmitted scalefactors of T3 should be used for re-quantisation of the subband samples.

A term  $TS_{ij}$  in the table means that the subband samples in transmission channel j have to be copied from transmission channel i. The input samples for the synthesis filter of transmission channel  $T_i$  are derived by multiplying the subband samples  $TS_{ij}$  by scalefactors  $scf_i$ . The input samples for the synthesis filter of transmission channel  $T_j$  are derived by multiplying the subband samples  $TS_{ij}$  by scalefactors  $scf_j$ . The rest of the decoding is the same as the situation without dynamic crosstalk.

**3/0 configuration**

If transmission channel T2 is missing, and the corresponding presentation channel is L, this channel is derived by multiplying the subband samples transmitted for Lo with the scalefactors transmitted in T2. If the missing presentation channel in T2 is C and dyn\_cross\_LR is '0', this channel is derived by multiplying the subband samples transmitted for Lo with the scalefactors transmitted in T2, if dyn\_cross\_LR is '1', this channel is derived by multiplying the subband samples transmitted for Ro with the scalefactors transmitted in T2.. If the missing presentation channel is R, this channel is derived by multiplying the subband samples transmitted for Ro with the scalefactors transmitted in T2. The rest of the decoding is the same as the situation without dynamic crosstalk.

**2/2 configuration**

If transmission channel T2 is missing, the presentation channels L or LS, which may be allocated to this transmission channel, are derived by multiplying the subband samples transmitted for Lo with the scalefactors transmitted in T2. If transmission channel T3 is missing, the presentation channels R or RS, which may be allocated to this transmission channel, are derived by multiplying the subband samples transmitted for Ro with the scalefactors transmitted in T3.

A term  $TS_{ij}$  in the table means that the subband samples in transmission channel j have to be copied from transmission channel i. The input samples for the synthesis filter of transmission channel  $T_i$  are derived by multiplying the subband samples  $TS_{ij}$  by scalefactors  $scf_i$ . The input samples for the synthesis filter of transmission channel  $T_j$  are derived by multiplying the subband samples  $TS_{ij}$  by scalefactors  $scf_j$ . The rest of the decoding is the same as the situation without dynamic crosstalk.

**2/1 configuration**

If transmission channel T2 is missing, the presentation channels L, which may be allocated to this transmission channel, is derived by multiplying the subband samples transmitted for Lo with the scalefactors transmitted in T2. If the missing presentation channel is R, this channel is derived by multiplying the subband samples transmitted for Ro with the scalefactors transmitted in T2. If the missing presentation channel is S, this channel is derived by multiplying the subband samples transmitted for Lo and Ro with the scalefactors transmitted in T2. The rest of the decoding is the same as the situation without dynamic crosstalk.

**2.5.3.2.3 MC\_Prediction**

If the mc\_prediction\_on bit is set and if the mc\_prediction[sbgr] bit is set, the predsi[sbgr][px] bits determine, which predictor is used and how many coefficients pred\_coef[sbgr] [px] [pci] are transmitted for each subband group sbgr. If predsi[sbgr][px] is 1, 2 or 3, the delay compensation delay\_comp[sbgr][px] and the next 1, 2 or 3 predictor



coefficients have to be read from the bit stream. The predictor coefficients are transmitted as 8 bit uimsbf values and have to be dequantised according to the following equation:

$$\text{pred\_coef}[\text{sbgr}][\text{px}][\text{pci}] = (\text{pred\_coef}[\text{sbgr}][\text{px}][\text{pci}] - 127)/32.$$

If less than three coefficients are transmitted, the remaining  $\text{pred\_coef}[\text{sbgr}][\text{px}][\text{pci}]$  are set to zero. If  $\text{predsi}[\text{sbgr}][\text{px}]$  is 0, all corresponding  $\text{pred\_coef}[\text{sbgr}][\text{px}][\text{pci}]$  are set to zero.

For the 3/2 configuration with "no dynamic crosstalk" ( $\text{dyn\_cross\_mode}[\text{sbgr}]=0$ ), the correspondence of the predictor coefficients stored in  $\text{pred\_coef}[\text{sbgr}][\text{px}][\text{pci}]$  to the transmission channels T2, T3 and T4 is as follows ( $\text{npred}=6$ ):

T2:  $\text{px}=0$  and  $\text{px}=1$ , i.e.

$$\begin{aligned} \text{pred\_coef\_T2\_0}[\text{sbgr},\text{pci}] &= \text{pred\_coef}[\text{sbgr}][\text{px}=0][\text{pci}] \\ \text{pred\_coef\_T2\_1}[\text{sbgr},\text{pci}] &= \text{pred\_coef}[\text{sbgr}][\text{px}=1][\text{pci}] \end{aligned}$$

T3:  $\text{px}=2$  and  $\text{px}=3$ , i.e.

$$\begin{aligned} \text{pred\_coef\_T3\_0}[\text{sbgr},\text{pci}] &= \text{pred\_coef}[\text{sbgr}][\text{px}=2][\text{pci}] \\ \text{pred\_coef\_T3\_1}[\text{sbgr},\text{pci}] &= \text{pred\_coef}[\text{sbgr}][\text{px}=3][\text{pci}] \end{aligned}$$

T4:  $\text{px}=4$  and  $\text{px}=5$ , i.e.

$$\begin{aligned} \text{pred\_coef\_T4\_0}[\text{sbgr},\text{pci}] &= \text{pred\_coef}[\text{sbgr}][\text{px}=4][\text{pci}] \\ \text{pred\_coef\_T4\_1}[\text{sbgr},\text{pci}] &= \text{pred\_coef}[\text{sbgr}][\text{px}=5][\text{pci}] \end{aligned}$$

For other configurations and the different dynamic crosstalk modes, the correspondence of the predictor coefficients to the transmission channels has to be adapted to the dynamic crosstalk tables (see clause 2.5.2.10), e.g.

3/2 configuration,  $\text{dyn\_cross\_mode}[\text{sbgr}]=9$ ,  $\text{npred}=4$

T2:  $\text{px}=0$  and  $\text{px}=1$ , i.e.

$$\begin{aligned} \text{pred\_coef\_T2\_0}[\text{sbgr},\text{pci}] &= \text{pred\_coef}[\text{sbgr}][\text{px}=0][\text{pci}] \\ \text{pred\_coef\_T2\_1}[\text{sbgr},\text{pci}] &= \text{pred\_coef}[\text{sbgr}][\text{px}=1][\text{pci}] \end{aligned}$$

T3: not transmitted => no prediction

T4:  $\text{px}=2$  and  $\text{px}=3$ , i.e.

$$\begin{aligned} \text{pred\_coef\_T4\_0}[\text{sbgr},\text{pci}] &= \text{pred\_coef}[\text{sbgr}][\text{px}=2][\text{pci}] \\ \text{pred\_coef\_T4\_1}[\text{sbgr},\text{pci}] &= \text{pred\_coef}[\text{sbgr}][\text{px}=3][\text{pci}] \end{aligned}$$

For each of the up to three signals transmitted in the transmission channels T2, T3 and T4 the prediction signals in each subband group sbgr are calculated as follows:

$$\bar{\mathbb{P}}_2(n) = \sum_{\text{pci}=0}^2 \text{pred\_coef\_T2\_0}[\text{sbgr},\text{pci}] * T_0(n - \text{delay\_comp} - \text{pci}) + \sum_{\text{pci}=0}^2 \text{pred\_coef\_T2\_1}[\text{sbgr},\text{pci}] * T_1(n - \text{delay\_comp} - \text{pci})$$

$$\bar{\mathbb{P}}_3(n) = \sum_{\text{pci}=0}^2 \text{pred\_coef\_T3\_0}[\text{sbgr},\text{pci}] * T_0(n - \text{delay\_comp} - \text{pci}) + \sum_{\text{pci}=0}^2 \text{pred\_coef\_T3\_1}[\text{sbgr},\text{pci}] * T_1(n - \text{delay\_comp} - \text{pci})$$

$$\bar{\mathbb{P}}_4(n) = \sum_{\text{pci}=0}^2 \text{pred\_coef\_T4\_0}[\text{sbgr},\text{pci}] * T_0(n - \text{delay\_comp} - \text{pci}) + \sum_{\text{pci}=0}^2 \text{pred\_coef\_T4\_1}[\text{sbgr},\text{pci}] * T_1(n - \text{delay\_comp} - \text{pci})$$

here  $T_0(n)$  and  $T_1(n)$  refer to the subband samples of  $T_0$  and  $T_1$  after requantisation and application of the scalefactors.

By adding the transmitted prediction error signals to the prediction signals, the signals in the subband group sbgr are reconstructed using the corresponding three, two or one of the following equations:

$$T_2(n) = \bar{\mathbb{P}}_2(n) + \mathcal{E}_{T_2}(n)$$

$$T_3(n) = \bar{\mathbb{P}}_3(n) + \mathcal{E}_{T_3}(n)$$

$$T_4(n) = \bar{\mathbb{P}}_4(n) + \mathcal{E}_{T_4}(n)$$

In those cases of the dynamic crosstalk modes, where combined signals - indicated by Txy or Txyz - are transmitted in one of the transmission channels T2, T3 or T4, the reconstruction is as follows:

$$\text{Txy: } T_x(n) = \bar{T}_x(n) + \mathcal{E}_{T_x}(n)$$

$$T_y(n) = \bar{T}_y(n) + \mathcal{E}_{T_y}(n)$$

$$\text{Txyz: } T_x(n) = \bar{T}_x(n) + \mathcal{E}_{T_x}(n)$$

$$T_y(n) = \bar{T}_y(n) + \mathcal{E}_{T_y}(n)$$

$$T_z(n) = \bar{T}_z(n) + \mathcal{E}_{T_z}(n)$$

### 2.5.3.3 Requantisation Procedure

See ISO/IEC 11172-3, subclauses 2.4.3.1 and 2.4.3.3.4.

### 2.5.3.4 Decoding of Scalefactors

See ISO/IEC 11172-3, subclause 2.4.3.3.3.

### 2.5.3.5 Decoding of Low Frequency Enhancement Channel

The Low Frequency Enhancement Channel is transmitted as block companded linear PCM coded samples, at a sampling frequency that is 96 times lower than the sampling frequency of the other channels. The requantisation of the transmitted samples and application of the scalefactors are as in ISO/IEC 11172-3 for Layers I. See ISO/IEC 11172-3, subclause 2.4.3.1.

### 2.5.3.6 De-normalisation procedure

In the decoder, the weighted signals  $L^W$ ,  $C^W$ ,  $R^W$ ,  $LS^W$ ,  $RS^W$  first have to be inverse weighted by multiplying the signals with the inverse weighting factors. Next, these signals can be multiplied by the de-normalization factor to undo the attenuation done at the encoder side to avoid overload when calculating the compatible signals.

dematrix_procedure	signals	inverse weighting factor	de-normalisation factor
0, 2	$L^W, R^W$	1	$1 + \sqrt{2}$
	$C^W, LS^W, RS^W$	$\sqrt{2}$	
1	$L^W, R^W$	1	$1,5 + 0,5 * \sqrt{2}$
	$LS^W, RS^W$	2	
	$C^W$	$\sqrt{2}$	
3	$L^W, R^W, C^W, LS^W, RS^W$	1	1

### 2.5.3.7 Synthesis Subband Filter

see ISO/IEC 11172-3, subclause 2.4.3.2.2

### 2.5.3.8 Layer III Decoding

#### 2.5.3.8.1 Layer III Segment Lists

The segment list syntax allows flexible joint stereo coding of multichannel signals while using only a few bits in the minimum case. The main idea is to construct each output audio channel from a pool of spectral data in the transmitted channels (TCs). This may vary for different parts of the channel spectrum (segments). For each segment, the length and the number of the source TC are transmitted (seg\_length, in units of scalefactorband\_groups and tc\_select, respectively). For Layer III, the following TC numbers are defined:

TC #	Channel	Symbolic
0	Lo	left_comp_chan
1	Ro	right_comp_chan
2	L	left_chan
3	R	right_chan
4	C	centre_chan
5	LS / S	left_surr_chan, mono_surr_chan
6	RS	right_surr_chan
7	„dematrixing“	-

In case a second stereo programme is transmitted (surround=='11') TCs 5 and 6 are used for the left and right channel respectively. If dematrix\_procedure 3 is used (no matrixing), the left and right channel signals are transmitted in TCs 0 and 1 respectively instead of TCs 2 and 3.

For each of the TCs there exists a similar data structure as for MPEG-1 Layer III audio channels, i.e. side information and huffman coded spectral values. The tc\_present flags are used to indicate which TCs are transmitted, i.e. how many sets of side information and main information are contained in the mc\_audio bit stream. In case of MPEG-2, the amount of side information for each channel is variable. Apart from this difference, decoding of the Huffman coded values works just as in an MPEG-1 decoder.

Each segment of an audio output channel, ch, has a default mapping to the corresponding TC (tc\_select == ch), but is assigned to a different TC for composite coding. In this case, an attenuation value is transmitted and applied to the TC spectral data to recover the audio output channel spectral data. In the special case of tc\_select==7, the respective segments are reconstructed by dematrixing.

For several segment list types, shortcuts have been defined:

- seglist\_present == 0 indicates a segment list in which the data of all covered scalefactorband\_groups are reconstructed by dematrixing (i.e. maximum segment length, tc\_select=7)
- seglist\_nodef == 0 indicates a simple "default" segment list in which the data of all covered scalefactorband\_groups are transmitted within the corresponding TC. (i.e. maximum segment length, tc\_select=ch)
- seglist\_repeat == 1 indicates that for granule 1 the same segment list is used as it has been transmitted for granule 0.

Segment lists can be either valid for only one of the granules or, as denoted by segment\_list\_repeat, be valid for both granules within one frame. A seg\_length of zero indicates that the segment list terminates and that the remaining part of the channel spectrum is set to zero.

For frequencies above the scalefactorband\_group border (denoted by dematrix\_length) the segment lists are used to denote channels which may be compositely coded. For scalefactorband\_groups lower than dematrix\_length, a less flexible method of assigning the actual transmitted channels is used which does not allow for composite coding.

dematrix\_select is a 3.4 bit value with 14 possible assignments (for 3/2 configuration). It is used to find which channels have to be dematrixed and which are transmitted. Two, one or even no channels are reconstructed by means of dematrixing. While segment lists are transmitted for each granule, dematrix\_select is valid for both granules.

**2.5.3.8.2 Decoding Process for Layer III**

If an extension bit stream is available, its access units may contain parts of mc\_composite\_status\_info and mc\_audio\_data. Their contents are concatenated to the mc\_composite\_status\_info and/or mc\_audio\_data in the main data part of the MPEG-1 compatible bit stream. The target of the mc\_data\_begin pointer is calculated in the buffer containing the concatenated bit stream.

The decoding process consists of the following steps:

- **Expansion of Default Segment List Types**  
This is done by evaluating seg\_list\_present, seg\_list\_nodef and seg\_list\_repeat. If these syntax elements indicate a shortcut is used, then a full segment\_list representation is expanded according to the shortcut definitions stated in subclause 2.5.3.8.1.
- **Construction of Decoding Maps**  
Construct a map data\_present[gr][tc][sfb] describing which spectral TC data (dependent on granule, transmitted channel and scalefactorband) are actually transmitted. This is done by determining the scalefactorbands which are referenced by dematrix\_select or the segment\_lists (as part of a scalefactorband\_group).  
In addition, construct a map js\_carrier[gr][tc][sbgr] describing which spectral TC data (dependent on granule, transmitted channel and scalefactorband\_group) are used as a carrier for joint stereo transmission. This is done for each audio channel ch by determining the scalefactorband\_groups which are referenced with a tc\_select != ch.
- **Decoding of TC Information**  
Requantise the TC data of all channels as indicated by tc\_present. This works just as in a Layer III MPEG-1 decoder using information in the elements: block\_type, scalefac\_l, scalefac\_s, scfsi, part2\_3\_length, big\_values, global\_gain, scalefac\_compress, table\_select, subblock\_gain, region0\_count, region1\_count, preflag, scalefac\_scale, count1table\_select. The requantisation operation is described in ISO/IEC 11172-3, subclause 2.4.3.4. The decoded data is the raw spectral information of the respective audio output channel, where all coefficients belonging to scalefactorbands with data\_present[gr][tc][sfb] == 0 have been left out.
- **Decoding of Multi Channel Prediction**  
The decoding of multi channel prediction is done similar to Layers I and II independently for each scalefactorband\_group sbgr. If mc\_prediction\_on is off, no decoding of prediction is required for any scalefactorband\_group. If the mc\_prediction\_sbgr[sbgr] flag is off, no prediction is used in the respective scalefactorband\_group and no further predictor information is transmitted. Prediction information is transmitted once for each frame and applies to both granules.

Calculation of possible prediction combinations and number of predictor coefficients

For each scalefactorband\_group sbgr the possible prediction combinations are calculated according to the following rules:

- Each channel can be a possible destination channel for multi channel prediction if (1) data is transmitted for one of the granules (data\_present[gr\_0][ch][sfb(sbgr)]!=0 || data\_present[gr\_1][ch][sfb(sbgr)]!=0) and (2) source and destination channel have the same block\_type.
- For each possible destination channel one or two source channels (and predictor coefficients) are possible:

Destination channel	Number of source channels	Source channel(s)
L	1	Lo
R	1	Ro

C, S	2	Lo, Ro
LS	1	Lo
RS	1	Ro

In case of joint stereo coding ( $js\_carrier[gr][ch][sbgr] \neq 0$ ), both source channels Lo and Ro are regarded as possible source channels. The value  $npredcoef$  denotes the total number of possible predictor coefficients in one  $scalefactorband\_group$ . For short blocks ( $block\_type == 2$ ),  $npredcoef$  is defined as zero for  $scalefactorband\_groups$  above 11 (i.e. above the number of defined  $scalefactorband\_groups$ ).

- For each possible coefficient, one bit in the predictor select information  $predsi[sbgr][ ]$  is transmitted. The bits for the possible coefficients are ordered according to the destination channel using the standard channel assignment order, i.e. L, R, C, Ls, Rs. If two source channels are possible for the destination channel, the first bit corresponds to the Lo and the second to the Ro source channel.

- If  $predsi[sbgr][pci]$  is 0, the corresponding coefficient  $pred\_coef[sbgr][pci]$  is set to 0. Otherwise a coefficient is transmitted. The ordering of the coefficients is the same as for the  $predsi$  information, i.e. the coefficients are ordered according to the destination channel (coarse ordering) and to the source channel (fine ordering). The coefficients are dequantised according to the following table:

Transmitted value	Dequantised value
0	-0.61199
1	-0.24565
2	0.24565
3	0.61199
4	1.15831
5	1.97304
6	3.18805
7	5

#### Calculation of prediction signals

In each of the referenced destination channels, the prediction signals are calculated and added to the transmitted prediction error signals by:

$$L += pred\_coef\_L[sbgr] * Lo$$

$$R += pred\_coef\_R[sbgr] * Ro$$

$$C += pred\_coef\_C1[sbgr] * Lo + pred\_coef\_C2[sbgr] * Ro$$

$$Ls += pred\_coef\_Ls[sbgr] * Lo$$

$$Rs += pred\_coef\_Rs[sbgr] * Ro$$

and for the case of joint stereo coding

$$JS += pred\_coef\_JS1[sbgr] * Lo + pred\_coef\_JS2[sbgr] * Ro$$

The addition of predicted signals is performed only for granules in which data is transmitted for the respective channels ( $data\_present[gr][ch][sbgr] \neq 0$ ).

- **Decoding of Channel Data**

Each output audio channel is assembled from the decoded TC data according to its segment list and  $dematrix\_select$  configuration. All  $scalefactorband\_groups$  that are reconstructed by dematrixing are to be omitted. The  $data\_present$  map is used to direct the coded spectral values from the TC data to the correct  $scalefactorband\_group$  positions in the spectrum buffer of the destination channels.

For composite coded segments (i.e. `tc_select != ch` && `tc_select != 7`), a scaling operation is applied to the spectral data using the transmitted attenuation values as follows:

- Determine the basic attenuation factor  $a_0$  ( $1/\sqrt{2}$  for `attenuation_scale==1`, else  $1/\sqrt{\sqrt{2}}$ )
- Apply scaling using the actual attenuation factor  $a$ :

$$a = \begin{cases} a_0^{attenuation} & \text{for } attenuation < 0.75 \cdot max\_attenuation \\ a_0^{attenuation-max\_attenuation} & \text{for } attenuation \geq 0.75 \cdot max\_attenuation \end{cases}$$

with  $max\_attenuation = 2^{attenuation\_range+2}$

• **Dematrixing**

Dematrixing is used to reconstruct the missing `scalefactorband_groups` (only for `dematrix_procedure < 3`, not for second stereo programme, i.e. `surround == 3`).

For the first `dematrix_length` number of `scalefactorband_groups`, the dematrixed parts are determined by the transmitted `dematrix_select` values for the whole frame. Above this border, they are defined by the segment list segments with `tc_select==7`. Dematrixing is done by recovering zero, one or two channels from the downmix equations for the 3/2 stereo configuration

$$Lo = \alpha \cdot (L + \beta \cdot C + \gamma \cdot LS) \quad \text{and} \quad Ro = \alpha \cdot (R + \beta \cdot C + \gamma \cdot RS)$$

or, in the case of 3/1 stereo configuration

$$Lo = \alpha \cdot (L + \beta \cdot C + \gamma \cdot S) \quad \text{and} \quad Ro = \alpha \cdot (R + \beta \cdot C + \gamma \cdot S)$$

where  $\alpha$  is an overall attenuation for all channels and  $\beta$  and  $\gamma$  are the attenuation factors of the centre and surround signals. For other stereo configurations, the downmixing equations can be derived from one of these by regarding the absent audio channels as zero. In the case of `dematrix_procedure == '10'`, the dematrixing equations are modified as is described in subclause 2.5.3.2.1.

The attenuation factor values are specified for each dematrixing procedure:

dematrix_procedure	$\alpha$	$\beta$	$\gamma$
0	$1/(1 + \sqrt{2})$	$1/\sqrt{2}$	$1/\sqrt{2}$
1	$1/(1,5 + 0,5 \cdot \sqrt{2})$	$1/\sqrt{2}$	0,5
2	$1/(1 + \sqrt{2})$	$1/\sqrt{2}$	$1/\sqrt{2}$

Phantom coded centre channel:

In the case of Phantom coding of the centre channel (`centre=='11'`), the appearance of coding noise in a dematrixed centre channel is suppressed by limiting the bandwidth of the dematrixed centre channel as shown:

Sampling frequency [ Hz ]	Number of valid lines in centre channel
48000	230
44100	238
32000	296

This step is carried out *before* a second channel is dematrixed.

Correction of joint stereo dematrixing:

If the `matrix_attenuation_present` flag is on, the standard procedure for channel dematrixing is modified. For the dematrixing operation, all joint stereo coded `scafactorband_group` data is previously scaled by an attenuation factor. This scaling is performed independently for both halves of the dematrixing equations involving `Lo` and `Ro`.

The scaling factor `m` is determined by the transmitted `matrix_attenuation` values

$$ml = 2^{-0,25 \cdot \text{matrix\_attenuation\_l}[\text{js\_ch}][\text{sbgf}]}$$

$$mr = 2^{-0,25 \cdot \text{matrix\_attenuation\_r}[\text{js\_ch}][\text{sbgf}]}$$

Here, `js_ch` denotes the TC where the actual spectral data for the joint stereo coded signals has been transmitted and `sbgf` denotes the `scafactorband_group` index.

This procedure is illustrated below for the case of joint stereo coding of L and C. The spectral data is transmitted in the TC of the L channel (i.e. TC 2). Thus, C is constructed from the same data using the corresponding attenuation value. Prior to dematrixing, L and C are scaled by a factor of `m`. This scaling operation is *not* applied to the final output channel data.

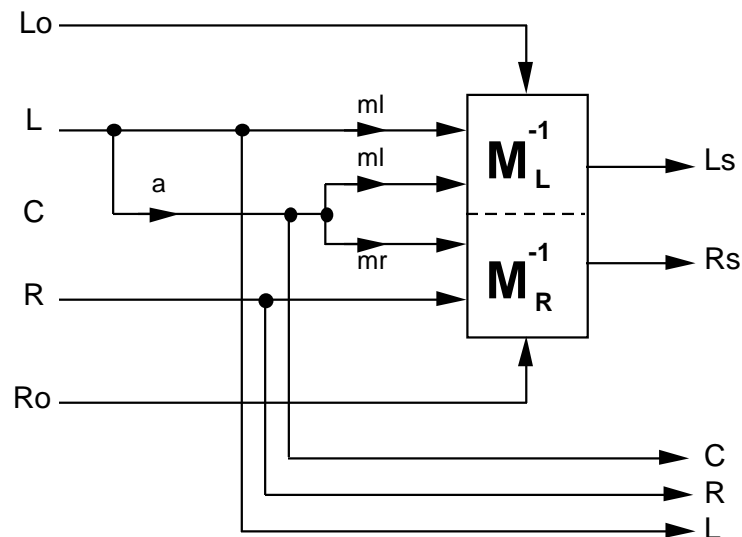

- **Synthesis Filterbank**

Apply the synthesis filterbank (see ISO/IEC 11172-3, subclause 2.4.3.4).

### 2.5.3.8.3 Decoding of LFE for Layer III

The LFE values are decoded from a simplified Layer III-type bit stream.

- The decoding of the Huffman coded values is done using the Huffman code table indicated by `lfe_table_select`.
- The decoding of transmitted Huffman codes is continued until all bits indicated by `lfe_hc_len` have been exhausted. After this process, the value of `lfe_bigval` is known. For clarity, this parameter is introduced to indicate the number of Huffman code words used to transmit the spectral data of the low frequency channel. The decoded components, `x` and `y`, are interpreted as values of the respective spectral coefficients for granules 0 and 1.
- Subsequently, the dequantisation is performed in a manner similar to the dequantisation of TC data. For this purpose, `lfe_gain` is used and a scalefactor and subblock gain of zero is assumed.
- As a synthesis filterbank for the low frequency enhancement channel, the inverse MDCT (IMDCT) for the reconstruction of data in short blocks (`block_type == 2`) is used that is described as part of the synthesis hybrid

filterbank in ISO/IEC 11172-3, subclause 2.4.3.4. Thus, the window type which is described under ISO/IEC 11172-3, subclause 2.4.3.4. / Windowing (d) is applied to the 12 IMDCT output samples of each granule. Because there is only one window per granule, the "overlap add" process simplifies to:

$$\begin{aligned} \text{result}_i &= y_i + s_i && \text{for } i=0 \text{ to } 5 \\ s_i &= y_{i+6} && \text{for } i=0 \text{ to } 5 \end{aligned}$$

#### 2.5.3.8.4 Decoding of ML Data for Layer III

If multilingual\_fs==0, see ISO/IEC 11172-3, subclause 2.4.3.4

If multilingual\_fs==1, see subclause 2.4.3.2

For use as ML main data, nch is set to no\_of\_multi\_lingual\_ch.



# Annex A

(normative)

## Diagrams

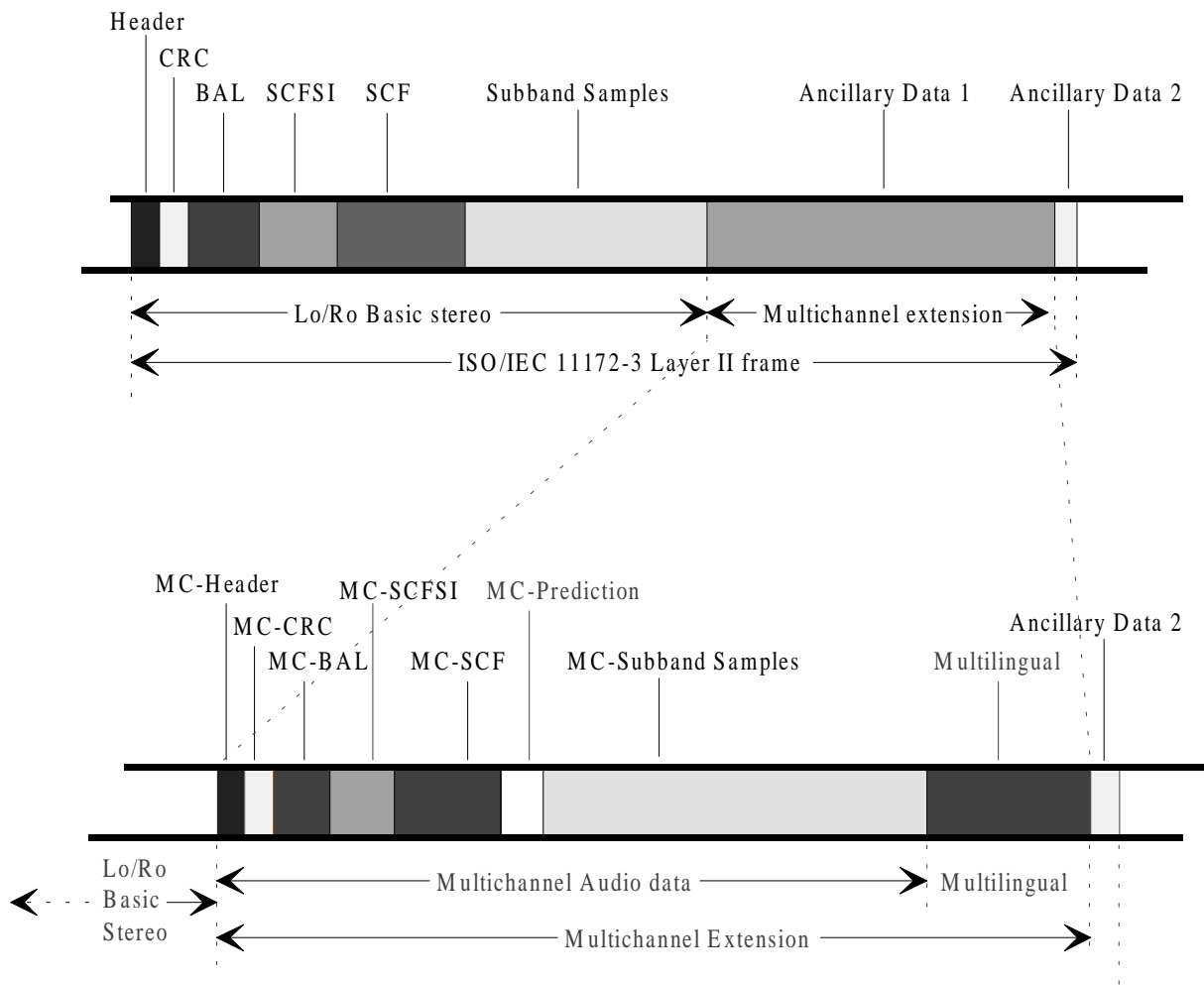

**Figure A.1 Structure of the ISO 13818-3 Layer II multichannel extension, backwards compatible with ISO 11172-3 Layer II**

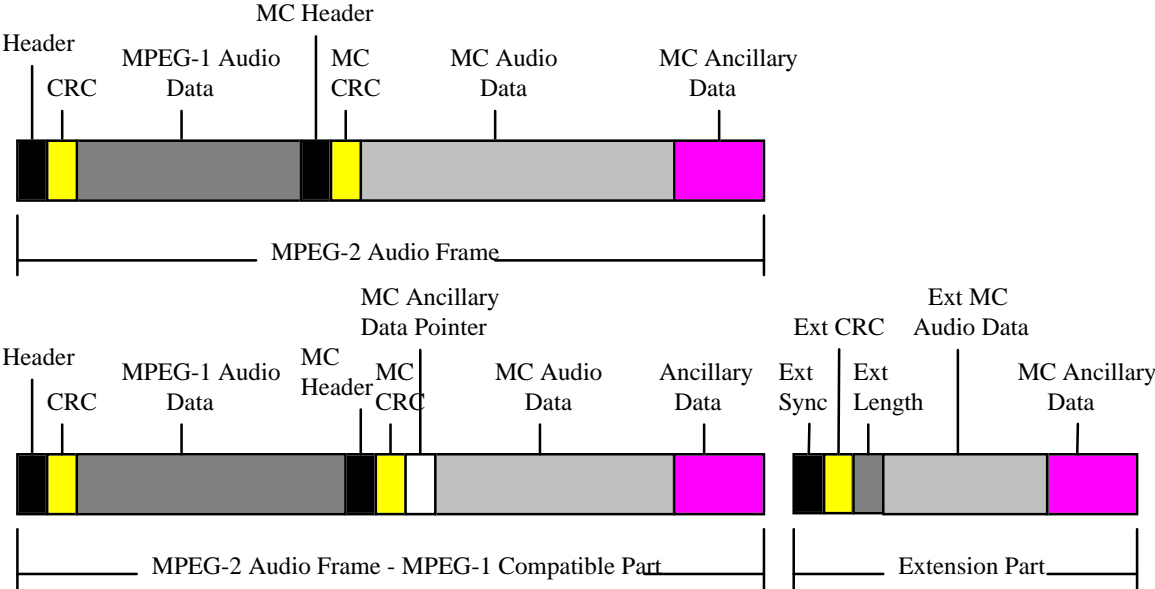

Figure A.2 Structure of the ISO 13818-3 Layer II multichannel extension, using the ISO/IEC 11172-3 compatible bit stream as well as the extension bit stream

## Annex B

(normative)

### Tables

**Table B.1. Possible quantisation per subband, Layer II**

Sampling frequencies 16, 22,05, 24 kHz.

		index																
sb	nbal	0	1	2	3	4	5	6	7	8	9	10	11	12	13	14	15	
0	4	–	3	5	7	9	15	31	63	127	255	511	1023	2047	4095	8191	16383	
1	4	–	3	5	7	9	15	31	63	127	255	511	1023	2047	4095	8191	16383	
2	4	–	3	5	7	9	15	31	63	127	255	511	1023	2047	4095	8191	16383	
3	4	–	3	5	7	9	15	31	63	127	255	511	1023	2047	4095	8191	16383	
4	3	–	3	5	9	15	31	63	127									
5	3	–	3	5	9	15	31	63	127									
6	3	–	3	5	9	15	31	63	127									
7	3	–	3	5	9	15	31	63	127									
8	3	–	3	5	9	15	31	63	127									
9	3	–	3	5	9	15	31	63	127									
10	3	–	3	5	9	15	31	63	127									
11	2	–	3	5	9													
12	2	–	3	5	9													
13	2	–	3	5	9													
14	2	–	3	5	9													
15	2	–	3	5	9													
16	2	–	3	5	9													
17	2	–	3	5	9													
18	2	–	3	5	9													
19	2	–	3	5	9													
20	2	–	3	5	9													
21	2	–	3	5	9													
22	2	–	3	5	9													
23	2	–	3	5	9													
24	2	–	3	5	9													
25	2	–	3	5	9													
26	2	–	3	5	9													
27	2	–	3	5	9													
28	2	–	3	5	9													
29	2	–	3	5	9													
30	0	–																
31	0	–																

sblimit = 30

Sum of nbal = 75

**Table B.2. Layer III scalefactor bands**

These tables list the width of each scalefactor band. There are 21 bands at each sampling frequency for long (type 0,1 or 3) windows and 12 bands each for short windows.

**16 kHz sampling rate, long blocks, number of lines 576**

scalefactor band	width of band	index of start	index of end
0	6	0	5
1	6	6	11
2	6	12	17
3	6	18	23
4	6	24	29
5	6	30	35
6	8	36	43
7	10	44	53
8	12	54	65
9	14	66	79
10	16	80	95
11	20	96	115
12	24	116	139
13	28	140	167
14	32	168	199
15	38	200	237
16	46	238	283
17	52	284	335
18	60	336	395
19	68	396	463
20	58	464	521
21	54	522	575

**16 kHz sampling rate, short blocks, number of lines 192**

scalefactor band	width of band	index of start	index of end
0	4	0	3
1	4	4	7
2	4	8	11
3	6	12	17
4	8	18	25
5	10	26	35
6	12	36	47
7	14	48	61
8	18	62	79
9	24	80	103
10	30	104	133
11	40	134	173
12	18	174	191

**22,05 kHz sampling rate, long blocks, number of lines 576**

scalefactor band	width of band	index of start	index of end
0	6	0	5
1	6	6	11
2	6	12	17
3	6	18	23
4	6	24	29
5	6	30	35
6	8	36	43
7	10	44	53
8	12	54	65
9	14	66	79
10	16	80	95
11	20	96	115
12	24	116	139
13	28	140	167
14	32	168	199
15	38	200	237
16	46	238	283
17	52	284	335
18	60	336	395
19	68	396	463
20	58	464	521
21	54	522	575

**22,05 kHz sampling rate, short blocks, number of lines 192**

scalefactor band	width of band	index of start	index of end
0	4	0	3
1	4	4	7
2	4	8	11
3	6	12	17
4	6	18	23
5	8	24	31
6	10	32	41
7	14	42	55
8	18	56	73
9	26	74	99
10	32	100	131
11	42	132	173
12	18	174	191

**24 kHz sampling rate, long blocks, number of lines 576**

scalefactor band	width of band	index of start	index of end
0	6	0	5
1	6	6	11
2	6	12	17
3	6	18	23
4	6	24	29
5	6	30	35
6	8	36	43
7	10	44	53
8	12	54	65
9	14	66	79
10	16	80	95
11	18	96	113
12	22	114	135
13	26	136	161
14	32	162	193
15	38	194	231
16	46	232	277
17	54	278	331
18	62	332	393
19	70	394	463
20	76	464	539
21	36	540	575

**24 kHz sampling rate, short blocks, number of lines 192**

scalefactor band	width of band	index of start	index of end
0	4	0	4
1	4	4	8
2	4	8	12
3	6	12	18
4	8	18	26
5	10	26	36
6	12	36	48
7	14	48	62
8	18	62	80
9	24	80	104
10	32	104	136
11	44	136	180
12	12	180	192

**Table B.3. Low-pass filter description**

In dematrix procedure '10', the following filter is to be applied in the decoder to retrieve the signal  $jS_{bp}^W$  from the monophonic surround signal  $jS^W$  before dematrixing. The same filter is preferably to be used in the encoder to produce the signal  $jS_{bp}^W$  before matrixing.

$$H(z) = \frac{a_0(1 + 2z^{-1} + z^{-2})}{b_0 + b_1z^{-1} + b_2z^{-2}}$$

The following table defines the coefficients  $a_0$ ,  $b_0$ ,  $b_1$  and  $b_2$  of the filter for the three different sampling frequencies.

Sampling frequency	$a_0$	$b_0$	$b_1$	$b_2$
32 kHz	486	2048	-471	370
44.1 kHz	295	2048	-1394	521
48 kHz	294	2048	-1388	520

## Annex C

(informative)

### The encoding process

#### C.1 Extension to lower sampling frequencies

In this part of the annex, the differences from ISO/IEC 11172-3 encoders are described.

##### C.1.1 Lower sampling frequencies, Layer I.

The only differences from the encoder described in ISO/IEC 11172-3 are the formatting and the psychoacoustic model. The encoded subband information is transferred in frames, consisting of slots. In Layer I, a slot consists of 32 bits. The number of slots in a frame depends on the sampling frequency and the bit rate. Each frame contains information on 384 samples for each channel of the original input signal.

Fs (kHz)	Frame size (ms)
24	16
22,05	17,415..
16	24

The number of slots in a frame can be calculated by the formula:

$$\text{Number of slots per frame (N)} = \text{bitrate} * 12 / F_s$$

The psychoacoustic model requires modification for the lower sampling frequency. See Annex D.1

##### C.1.2 Lower sampling frequencies, Layer II.

The differences from the encoder described in ISO/IEC 11172-3 are the formatting, the possible quantisations, and the psychoacoustic model. The encoded subband information is transferred in frames, consisting of slots. In Layer II, a slot consists of 8 bits. The number of slots in a frame depends on the sampling frequency and the bit rate. Each frame contains information on 1152 samples for each channel of the original input signal.

Fs (kHz)	Frame size (ms)
24	48
22,05	52,245..
16	72

The number of slots in a frame can be calculated by the formula:

$$\text{Number of slots per frame (N)} = \text{bitrate} * 144 / F_s$$

Instead of the tables B.2. "Layer II bit allocation tables, Possible Quantisation per Subband" of ISO/IEC 11172-3, the table B.1 "Possible quantisation per subband, Layer II" of this document must be used.

The psychoacoustic model requires modification for the lower sampling frequency. See Annex D.1



### C.1.3 Lower sampling frequencies, Layer III

The differences from the encoding process described in 11172-3 Layer III are the changed scalefactor band tables, the omission of some side information due to the changed frame layout, and some changed tables in the psychoacoustic model. All the basic steps described in 11172-3 apply, with the exception of the calculation of the scalefactor select information.

## C.2 Multichannel extension

In this part of the annex, two examples of suitable multichannel encoders are described, one for Layers I and II, and one for Layer III. The examples are valid for a 5+1 channel configuration, (i.e. Left, Centre, Right, Left Surround, Right Surround, and a low frequency enhancement channel), and for the multilingual extension the same layer as for the multichannel extension.

### C.2.1 Multichannel extension Layer I, II

#### C.2.1.1 The filterbank

The filterbanks used are the same as in ISO/IEC 11172-3, i.e. a 32-band polyphase filterbank for all Layers, followed by an MDCT on the subband signals for Layer III only. The subband filter has to be applied to all five channels

#### C.2.1.2 Calculation of scalefactors

The calculation of scalefactors and, for Layer II, scalefactor select info, is done in exactly the same way as in ISO/IEC 11172-3.

#### C.2.1.3 Psychoacoustic models

The two psychoacoustic models as described in ISO/IEC 11172-3 apply here as well. For all five channels, the signal-to-mask ratios of all subbands are calculated.

#### C.2.1.4 Predistortion

Predistortion ( or prequantisation) is used to prevent unmasked and unexpected noise from audio channels when dematrixing is performed in the decoder. This noise can appear because dematrixing in the decoder is performed with different multichannel extension signals than used for the matrixing process at the encoder. Only quantised samples are available in the decoder. The audible artefacts can be avoided by prequantisation of these samples in the encoder, prior to the matrixing. The following procedure can be used.

For each subband group :

step 1 : transmission channel switching procedure; choice of the multichannel extension signals T2, T3, T4 and associated tc\_allocation;

If tc\_allocation[sbgr] equals 1 or 7:

step 2 : coding and decoding of T2, and T3 according to the masking thresholds calculation,

step 3 : matrixing using the predistorted versions of T2 and T3 in order to obtain Lo,

step 4 : calculation of the predistorted centre signal as it will be derived at the decoder side after encoding and decoding of Lo

step 5: matrixing using the predistorted centre and the predistorted version of T4 to obtain Ro.

If tc\_allocation[sbgr] equals 2 or 6:

step 2: coding and decoding of T2, and T4 according to the masking thresholds calculation,

step 3: matrixing using the predistorted versions of T2 and T4 in order to obtain Ro,

step 4: calculation of the predistorted centre signal as it will be derived at the decoder side after encoding and decoding of Ro

step 5: matrixing using the predistorted centre and the predistorted version of T3 to obtain Lo.

If tc\_allocation[sbgr] equals 0,3,4 or 5

step 2: coding and decoding of T2, T3, T4 according to the masking thresholds calculation,

step 3: matrixing using the predistorted versions of T2, T3, T4 in order to get the compatible pair (Lo, Ro).

If the Centre signal is dominant in a certain subband group, it is recommended to use only tc\_allocations that do not contain the Centre signal in one of the additional transmission channels.

### C.2.1.5 Matrixing

First, all signals have to be attenuated to avoid overload when calculating the compatible stereo signal. The attenuation factor depends on the chosen matrix procedure.

Procedure 0, 2:  $1/(1 + \sqrt{2})$

Procedure 1:  $1/(1,5 + 0,5*\sqrt{2})$

Procedure 3: 1

Next, the Centre, Left Surround and Right Surround signals have to be attenuated before the compatible stereo signal is calculated. These attenuation factors are

Procedure 0, 2: C,LS,RS  $1/\sqrt{2}$

Procedure 1: C  $1/\sqrt{2}$

LS,RS 0,5

Procedure 3: C,LS,RS 1

The signals after this attenuation are called  $C^W, LS^W, RS^W$ .

Next the compatible signal has to be calculated according to

Procedure 0, 1:  $Lo = L^W + C^W + LS^W$   
 $Ro = R^W + C^W + RS^W$

Procedure 2:  $Lo = L^W + C^W - jS_{bp}^W$   
 $Ro = R^W + C^W + jS_{bp}^W$

The signals to be transmitted in T3 and T4 are derived from  $LS^W$  and  $RS^W$  by half Dolby® B-type encoding, and 90 degrees phase shifting.  $jS_{bp}^W$  is derived from  $jLS^W$  and  $jRS^W$  by calculation of the mono component and bandwidth limitation. The filter preferably to be used is described in table B.3 of Annex B. With other filters, the dematrixing will not be perfect.

Procedure 3:  $Lo = L^W$   
 $Ro = R^W$

### C.2.1.6 Dynamic transmission channel switching

To avoid audible artefacts due to the dematrixing process, it is necessary to choose the correct transmission channel allocation. This applies for matrix procedures 0, 1, and 2. A simple, but effective, approach is to choose for the

transmission channels T2, T3, T4 those channels that have the lowest scalefactors in the subband group under consideration. In subband groups that consist of more than one subband, first the maximum of the scalefactors of all subbands in a subband group has to be determined for each of the signals. Then the three signals with the lowest of the maximum scalefactor (highest scalefactor index) are allocated to the transmission channels T2, T3, and T4. If the transmission channel allocation is the same or almost the same for all subband groups, the `tc_sbgr_select` bit can be set to 0, in which case only one `tc_allocation` has to be sent for all subband groups.

### C.2.1.7 Dynamic Crosstalk

According to a binaural model of the human ear, those components of two- or multichannel stereophonic signals can be determined to a large extent, which are irrelevant with respect to the spatial perception of the stereophonic presentation. The stereo-irrelevant signal components are not masked, however, on the other hand, they do not contribute to the localisation of sound sources. Therefore, not all transmission channels, in particular those containing stereo-irrelevant components, have to be transmitted during all the time. In such a case, any channel of a multichannel stereo signal (L, C, R, LS or RS) may be substituted by any other channel. This may happen either in subband groups, whereby up to 12 those groups are available, or even for the whole audio channel. On the decoding side, this channel, or part of the channel, has to be reproduced via any presentation channel, or via several presentation channels, without effecting the stereophonic impression.

The dynamic crosstalk method used in Layer I and II is based on the concept of intensity stereo coding, described in Annex G of ISO/IEC 11172-3, but allows much more flexibility between the different channels and gives a much higher resolution in terms of frequency bands. Dynamic crosstalk can be used to increase the audio quality at a given bitrate, and/or reduces the bitrate for multichannel audio signals for a certain level of quality. This method requires negligible additional decoder complexity, and does not affect the encoder and decoder delay.

Dynamic crosstalk is based on known psychoacoustic effects. On one side, this method uses, like the intensity stereo coding, the effect, that at high frequencies the localisation is mainly based on the temporal envelope and not by the temporal fine structure of the audio signal. On the other side, dynamic crosstalk is based on the fact, that only fast changes in the temporal envelope of the audio signal are important for the localisation. However, the more stationary parts, in particular after attacks, have a much weaker effect on localisation. This means that for certain time intervals in certain regions of the spectrum, crosstalk is permissible. Those signals have to be identified by means of a signal analysis in the encoder, which can be set to "mono" and transmitted in only one channel. The signals can be identified on the basis of subband groups. Up to three transmission channels of the multichannel extension part can be substituted.

Only the corresponding scalefactors and `scfsi`, but no bit allocation and subband samples are transmitted for those channels which will be substituted in the decoder by dynamic crosstalk. As a result, the so-called "Gestalt" information of the image is completely available in the basic channels Lo/Ro, and only the relevant stereophonic information is transmitted in the extension channels.

A `Txy` in the dynamic crosstalk tables in subclause 3.5.2.10 means, that the subband samples of the representation channels indicated in the `tc-allocation` table (also given in subclause 3.5.2.10) are added, as described in Annex G of ISO/IEC 11172-3. The bit allocation and subband samples are transmitted in the transmission channel Tx. The scalefactors and `scfsi` of the representation channels, corresponding to Tx and Ty, have to be transmitted in the transmission channels Tx and Ty. This allows for a transmission of the level control information for both channels to reproduce the temporal slope of both representation channel corresponding to Tx and Ty. The entries in the dynamic crosstalk table allow for a very flexible use of intensity stereo coding.

### C.2.1.8 Adaptive Multichannel Prediction

Adaptive multichannel prediction is used to reduce the inter-channel redundancy. When using multichannel prediction, the signals in the transmission channels T2..T4 are predicted from the signals in the MPEG-1 compatible part of the bit stream (Lo, Ro). Instead of the actual signals in a subband group, the prediction error is transmitted, together with predictor coefficients and delay compensation.

The possible prediction equations are (all calculations are done on a frame by frame basis) :

$$\begin{aligned}\bar{T}_2(n) &= \sum_{pci=0}^2 \text{pred\_coef\_T2\_0}[sbgr, pci] * T_0(n - \text{delay\_comp} - pci) + \sum_{pci=0}^2 \text{pred\_coef\_T2\_1}[sbgr, pci] * T_1(n - \text{delay\_comp} - pci) \\ \bar{T}_3(n) &= \sum_{pci=0}^2 \text{pred\_coef\_T3\_0}[sbgr, pci] * T_0(n - \text{delay\_comp} - pci) + \sum_{pci=0}^2 \text{pred\_coef\_T3\_1}[sbgr, pci] * T_1(n - \text{delay\_comp} - pci) \\ \bar{T}_4(n) &= \sum_{pci=0}^2 \text{pred\_coef\_T4\_0}[sbgr, pci] * T_0(n - \text{delay\_comp} - pci) + \sum_{pci=0}^2 \text{pred\_coef\_T4\_1}[sbgr, pci] * T_1(n - \text{delay\_comp} - pci) \text{ In}\end{aligned}$$

stead of T2, T3 and T4, the prediction error signals

$$\mathcal{E}_{T_2}(n) = T_2(n) - \bar{T}_2(n)$$

$$\mathcal{E}_{T_3}(n) = T_3(n) - \bar{T}_3(n)$$

$$\mathcal{E}_{T_4}(n) = T_4(n) - \bar{T}_4(n)$$

are transmitted.

The predictor coefficients  $\text{pred\_coef}[sbgr, px, pci]$  are calculated such that the power of the prediction error signals is minimised resulting in the optimum prediction gain. The prediction gain is the ratio of the energies of the original signals and the corresponding prediction error signals, expressed in dB. A detailed description of these calculations is given below.

By comparing the actual prediction gain with the amount of side information required to code the predictor coefficients, it is decided for which subband groups and for which signals ( $L^W$ ,  $R^W$ ,  $C^W$ ,  $LS^W$ ,  $RS^W$  and  $S^W$ ) prediction is used in each frame. The 8 bits needed to code one predictor coefficient correspond to a prediction gain of 1,34 dB.

If the prediction error signal is transmitted instead of the original signal, the SMR-values used for the bit allocation procedure have to be reduced by the calculated prediction gain. To provide the SCFSI information necessary for the bit allocation, "preliminary" versions of the transmitted prediction error signals have to be calculated.

To avoid the summing of different quantisation errors, it is recommended to quantise and dequantise the signals  $L_0$ ,  $R_0$  and the predictor coefficients before the "final" prediction error signals are calculated. Thus, the prediction error signals will be identical in the coder and decoder.

The coding of the transmitted signals  $T_0$ ,  $T_1$ ,  $T_2$ ,  $T_3$ ,  $T_4$  is performed as usual using "allocation", "SCFSI", "scalefactor" and "sample".

### Encoding of one frame

- {
- subband filtering;
- matrixing;
- scalefactor calculation;
- transmission pattern calculation (SCFSI);
- calculation of the SMR values by the psychoacoustic model;
- transmission channel allocation
- dynamic cross-talk
- calculation of delay compensation, predictor coefficients and prediction gain;
- calculation of the predictor select information (PREDSI);
- calculation of the modified SMR values;
- quantisation of the predictor coefficients;
- calculation of the preliminary prediction error signals;
- scalefactor calculation;
- transmission pattern calculation (SCFSI);
- bit allocation (using modified SMR values);

```

- quantisation of the subband samples;
- dequantisation of the subband samples;
- calculation of the final prediction error signals (using the dequantised subband samples)
- scalefactor calculation;
- transmission pattern calculation (SCFSI);
- quantisation of the subband samples;
- bit stream formatting;
}

```

Calculation of the predictor coefficients, prediction gain and predictor select information

The following c-like description is a simple example of the prediction calculation for the case that the transmission channels T2, T3, T4 contain respectively C, LS, RS, no use is made of dynamic cross-talk, and only zero order predictor with no delay compensation is used. The output of the procedure consists of the coefficients coef\_0, coef\_1, coef\_2, coef\_3 and the corresponding predictor select information predsi[0..3]. In the current example, the meaning of coef\_0..coef\_3 is:

```

pred_coef_C0 = coef_0;
pred_coef_C1 = coef_1;
pred_coef_LS = coef_2;
pred_coef_RS = coef_3;

```

The procedure to be followed in other cases is similar.

```

for (sbgr=0; sbgr<12; sbgr++){
/* calculation of variances and correlation functions
   using short-term estimates */

st1 = st2 = sc = sls = srs = 0;
ct1c = ct2c = ct1t2 = ct1ls = ct2rs = 0;
numsb=((sbgr==11)?sblimit:sbgr_min[sbgr+1]) - sbgr_min[sbgr];
for (sb=sbgr_min[sbgr]; sb<sbgr_min[sbgr]+numsb; sb++){
  for (gr=0; gr<3; gr++){
    for (i=0; i<12; i++){
      st1 += sqr(sb_sample[0][gr][i][sb]);
      st2 += sqr(sb_sample[1][gr][i][sb]);
      sc += sqr(sb_sample[2][gr][i][sb]);
      sls += sqr(sb_sample[3][gr][i][sb]);
      srs += sqr(sb_sample[4][gr][i][sb]);
      ct1c+= sb_sample[0][gr][i][sb]*sb_sample[2][gr][i][sb];
      ct2c+= sb_sample[1][gr][i][sb] * sb_sample[2][gr][i][sb];
      ct1t2+= sb_sample[0][gr][i][sb] * sb_sample[1][gr][i][sb];
      ct1ls+=sb_sample[0][gr][i][sb] * sb_sample[3][gr][i][sb];
      ct2rs+=sb_sample[1][gr][i][sb] * sb_sample[4][gr][i][sb];
    }
    st1 = sqrt (st1/(3*12*numsb));
    st2 = sqrt (st2/(3*12*numsb));
    sc = sqrt (sc/(3*12*numsb));
    sls = sqrt (sls/(3*12*numsb));
    srs = sqrt (srs/(3*12*numsb));
    st1 = (st1>MIN_S)?st1:MIN_S; /* to avoid division by 0 */
    st2 = (st2>MIN_S)?st2:MIN_S;
    sc = (sc>MIN_S)?sc:MIN_S;
    sls = (sls>MIN_S)?sls:MIN_S;
    srs = (srs>MIN_S)?srs:MIN_S;
    ct1c = ct1c / (st1*sc);
    ct2c = ct2c / (st2*sc);
  }
}

```

```

ct1t2 = ct1t2 / (st1*st2);
ct1ls = ct1ls / (st1*s1s);
ct2rs = ct2rs / (st2*srs);
/* calculation of predictor coefficients */
coef_0 = sc / st1 * ct1c;
coef_1 = sc / st2 * ct2c;
coef_x0 = sc / st1 * (ct1c - ct2c*ct1t2) / (1 - sqrt(ct1t2));
coef_x1 = sc / st2 * (ct2c - ct1c*ct1t2) / (1 - sqrt(ct1t2));
coef_2 = s1s / st1 * ct1ls;
coef_3 = srs / st2 * ct2rs;
/* calculation of prediction gains */
/* problem: if sbgr contains more than one subband the */
/* prediction gain can be different in the subbands!!! */
gain_0 = 10 * log (1/(1 - sqrt(ct1c)));
gain_1 = 10 * log (1/(1 - sqrt(ct2c)));
gain_2 = 10 * log (1/(1 - sqrt(ct1ls)));
gain_3 = 10 * log (1/(1 - sqrt(ct2rs)));
temp = sqrt(sc) - 2*(coef_x0*ct1c*st1*sc) - 2*(coef_x1*ct2c*st2*sc)
      + 2*(coef_x0*coef_x1*ct1t2*st1*st2) + sqrt(coef_x0*st1)
      + sqrt(coef_x1*st2);
gain_01 = 10 * log (sqrt(sc) / temp);
/* calculation of predictor select information */
maxgain = 0;
maxmode = 0;
if (gain_0 - SI_COEF/numsb > maxgain) {
    maxgain = gain_0 - SI_COEF/numsb;
    maxmode = 1;
}
if (gain_1 - SI_COEF/numsb > maxgain) {
    maxgain = gain_1 - SI_COEF/numsb;
    maxmode = 2;
}
if (gain_01 - 2*SI_COEF/numsb > maxgain) {
    maxgain = gain_01 - 2*SI_COEF/numsb;
    maxmode = 3;
}
switch (maxmode){
case 0 :
    temp_pred_gain[0] = 0;
    predsi[0] = 0;
    predsi[1] = 0;
    break;
case 1 :
    temp_pred_gain[0] = gain_0;
    predsi[0] = 1;
    predsi[1] = 0;
    pred_coef[sbgr][0] = coef_0;
    break;
case 2 :
    temp_pred_gain[0] = gain_1;
    predsi[0] = 0;
    predsi[1] = 1;
    pred_coef[sbgr][1] = coef_1;
    break;

```

```

case 3 :
    temp_pred_gain[0] = gain_01;
    predsi[0] = 1;
    predsi[1] = 1;
    pred_coef[sbgr][0] = coef_x0;
    pred_coef[sbgr][1] = coef_x1;
    break;
}
if (gain_2 > SI_COEF/numsb){
    temp_pred_gain[1] = gain_2;
    predsi[2] = 1;
    pred_coef[sbgr][2] = coef_2;
}
else{
    temp_pred_gain[1] = 0;
    predsi[2] = 0;
}
if (gain_3 > SI_COEF/numsb){
    temp_pred_gain[2] = gain_3;
    predsi[3] = 1;
    pred_coef[sbgr][3] = coef_3;
}
else{
    temp_pred_gain[2] = 0;
    predsi[3] = 0;
}
/* simplifying assumption: prediction gain is the same in */
/* all subbands of one subband group */
for (sb=sbgr_min[sbgr]; sb<sbgr_min[sbgr]+numsb; sb++)
    for (i=0; i<3; i++)
        pred_gain[i][sb] = temp_pred_gain[i];
/* modification of the SMR values according to the prediction gain */
/* i.e.: SMR is reduced by the prediction gain */
for (sb=sbgr_min[sbgr]; sb<sbgr_min[sbgr]+numsb; sb++)
    for (i=0; i<3; i++)
        smr[i+2][sb] -= pred_gain[i][sb];
} /* for (sbgr=0; sbgr<12; sbgr++) */

```

### C.2.1.9 Phantom coding of centre channel

If there is a shortage of bits, the use of Phantom coding of the centre channel can provide a significant gain in an unobtrusive way. The centre signal is low-pass and high-pass filtered to obtain a low and a high frequency part. The high frequency part of the centre channel is attenuated by 3 dB, and added to the left and right channels. The filtering and summation should be done in the PCM domain, to avoid aliasing problems at the subband bound above which the Phantom coding is done. The centre bits in the multichannel bit stream have to be set to '11'. Only the bit allocation, scalefactor select information, scalefactors, and sample data of the low frequency part of the centre signal are actually transmitted.

### C.2.1.10 Bit Allocation

The bit allocation procedure is similar to that used in ISO/IEC 11172-3, but now applies to 5 channels and, optionally, a low frequency enhancement channel. In Layer I, the procedure is slightly different because the compatible part requires three bit allocations, while the extension part requires only one bit allocation. A simple way

to approach this is to use the same bit allocation for the backwards compatible part of each three consecutive Layer I frames, and to triple the bit required for side information and samples of this part. After this, it can be treated the same as in Layer II. From the total number of available bits, 2 bits have to be subtracted, because one bit, which is set to zero, has to be inserted at the end of the first two of each three consecutive frames. This is for synchronisation purposes in the case of a bit oriented channel without further framing.

#### **C.2.1.11 Multilingual**

The encoding of multilingual channels can be done at the same sampling frequency as that of the compatible and multichannel data in the bit stream, or at half that sampling frequency. In the latter case, a significant gain in coding efficiency is obtained at the expense of a reduction in bandwidth. If the bandwidth of the input signal is already limited, as in case of speech signals, this bandwidth limitation is no real drawback.

If the full sampling frequency is used, the encoding is done according to ISO/IEC 11172-3, with the exception that no intensity stereo coding is possible and up to seven channels can be multiplexed. If the half sampling frequency is used, the encoding is done according to the extension to lower sampling frequencies as described in subclause C.1.2, with the exception that no intensity stereo coding is possible, that up to seven channels can be multiplexed, and that the frames contain half the number of subband samples, and thus have half the duration.

#### **C.2.1.12 Formatting**

The multichannel / multilingual bit stream has to be formatted according to the syntax in subclause 3.5.1. In Layer II, the multichannel bit stream has to be inserted directly after the backwards compatible part of the bit stream. The remaining bits in the frame can be used for ancillary data. In Layer I, the multichannel bit stream consists basically of three parts, distributed over three Layer I frames. Part 1 has to start directly after the backwards compatible part of the bit stream, and ends 1 bit before the next syncword. The last bit of the frame is set to zero. Part 2 starts directly after the backwards compatible part of the next frame, and ends 1 bit before the end of that frame. Again, the last bit is set to zero. Part 3 starts directly after the backwards compatible part of the next frame, and ends before the end of that frame. The remaining bits can be used for ancillary data.

### **C.2.2 Multichannel extension Layer III**

#### **C.2.2.1 Psychoacoustic models**

The two psychoacoustic models as described in ISO/IEC 11172-3 are also suitable here. For all five channels and for the compatible channels, the threshold levels for all scalefactor bands are calculated. If encoding is done with matrix procedures (i.e. `dematrix_procedure < 3`), the `block_types` of all channels should be the same for optimum system operation. This is achieved by applying the window switching sequence described in ISO/IEC 11172-3, clause C.1.5.3 / 2 to all channels when the condition for window switching is fulfilled in at least one of the channels.

#### **C.2.2.2 The filterbank**

The filterbank used is the same as in ISO/IEC 11172-3, i.e. a 32-band polyphase filterbank, followed by an MDCT on the subband signals and some processing for aliasing reduction (see ISO/IEC 11172-3, clause C.1.5.3 / 3). The filterbank is applied to all five channels according to the `block_type` values which have been calculated by the psychoacoustic model.



### C.2.2.3 Segment list processing

Segment lists are a general way to introduce joint stereo coding where the output to one channel is derived as a scaled version of the data in a different channel. A requirement for application of segment\_list processing is that all channels use the same block\_type. This is recommended for coding of multichannel signals except for dematrix\_procedure==3. In this case, all channels which are grouped together by composite coding should have the same block\_type.

While the syntax allows for several segments containing different joint stereo modes within one block, it is possible to restrict the use of segment\_lists to one segment at high frequencies. This is the recommended practice for the encoder described here.

The application of joint stereo coding is done in a controlled way by using a joint stereo detection procedure in order to determine the best joint stereo combinations between the channels. The variable dematrix\_length indicates the separation point between adaptive dematrixing and joint stereo processing.

Joint stereo detection is done for all possible values of dematrix\_length, from 0 to 14. Dematrix\_length is set equal to the lowest index of dematrix\_length where joint stereo detection shows an anticipated gain from joint stereo coding while also meeting the requirements for a virtually unimpaired image impression.

Joint stereo detection is accomplished using a search for the best joint stereo combination. Using all reasonable combinations of channels (like L+LS, R+RS, L+C+LS, R+C+RS, LS+RS etc.), the simulated joint stereo combination and the original are compared. This comparison is done by evaluating the short time energies of original and simulated joint stereo signals. If the relative energy deviation is greater than 0.03, joint stereo is not viable for this combination. In parallel, the reduction in bitrate possible from joint stereo coding is estimated using the Perceptual Entropy (PE). The combination of channels offering minimum quality loss, as indicated by the short time energy ratio, and, at the same time, the most gain in terms of PE is selected.

For the transmission of the selected joint stereo combination, one channel is used as the "carrier" for this combination. This carrier channel contains the spectral information of the joint stereo combination. The carrier channel is chosen from all combination channels as the combination channel with the highest energy.

### C.2.2.4 Dynamic transmission channel switching

In order to avoid audible artefacts due to the dematrixing process, it is necessary to choose the right transmission channel allocation. This can be done in several possible ways:

- Selection of a whole channel for transmission can be done with a few bits of side information using the "seglist\_present" syntax. For a valid Layer III bit stream, the encoder may select up to two channels for dematrixing by setting seglist\_present[ ] to zero. In this case, the corresponding tc\_present[ ] can be set to zero indicating that no further side information for the corresponding TC is transmitted.
- To have better control of the dematrixing configuration, the selection of the transmitted channels can be done on a scalefactorband group by scalefactorband group basis. This can be achieved by using the dematrix\_select syntax. For scalefactorband groups above dematrix\_length, the same effect can be reached by selecting a tc\_select value of 7 for the respective segment.

The selection process can be based on the following criterion: For each channel, its masking ability (masked threshold, xmin) is calculated by the psychoacoustic model as for MPEG-1 Layer III encoding (see ISO/IEC 11172-3, clause C.1.5.3). From all channels, the two channels with the strongest masking ability are chosen for reconstruction by dematrixing and thus do not need to be transmitted. In case one of the channels is the centre channel and the computed masked thresholds differ by more than 6dB, only the channel with the strongest masking ability is selected for dematrixing.

### C.2.2.5 Matrixing

The compatible stereo signals  $L_o$  /  $R_o$  are calculated from the multi-channel signals as follows:

$$\text{Procedure 0, 1, 3: } L_o = \alpha * (L + \beta * C + \gamma * LS)$$

$$R_o = \alpha * (R + \beta * C + \gamma * RS)$$

and

$$\text{Procedure 2: } L_o = \alpha * (L + \beta * C - \gamma * jS)$$

$$R_o = \alpha * (R + \beta * C + \gamma * jS)$$

where  $jS$  is derived from  $LS$  and  $RS$  by calculation of the mono component, bandwidth limitation to the range 100-7000 Hz, half Dolby<sup>®</sup> B-type encoding, and 90 degrees phase shifting.

In the above equations,  $\alpha$  is an overall attenuation for all channels and  $\beta$  and  $\gamma$  are the attenuation factors of the centre and surround signals. The attenuation factor values are specific to each dematrixing procedure:

dematrix_procedure	$\alpha$	$\beta$	$\gamma$
0	$1/(1 + \sqrt{2})$	$1/\sqrt{2}$	$1/\sqrt{2}$
1	$1/(1,5 + 0,5*\sqrt{2})$	$1/\sqrt{2}$	0,5
2	$1/(1 + \sqrt{2})$	$1/\sqrt{2}$	$1/\sqrt{2}$
3	1	0	0

Please note that, unlike in Layers I and II, all handling of the multi-channel stereo signals  $L$ ,  $R$ ,  $C$ ,  $L_s$ ,  $R_s$ ,  $S$  is done without applying a weighting procedure.

### C.2.2.6 Adaptive multichannel prediction

Adaptive Multichannel Prediction can be used in Layer III multichannel coding in the same way as in Layer I and II except that the prediction procedure is applied to the output values of the hybrid filterbank.

### C.2.2.7 Quantization and coding

For subsequent coding, the output data of all five input channels and the two compatible channels are converted to a TC representation. This is done by removing all spectral parts from the output channel spectra of the filterbank which do not have to be transmitted. There are two cases where spectral parts are excluded from transmission:

- Spectral data which is reconstructed in the decoder by dematrixing will be excluded from transmission in the TCs. This is done according to the result of the dynamic transmission channel switching.
- In the case of joint stereo coding, only the carrier portion of the involved channel data is transmitted in the TCs. All other involved channel data is reconstructed in the decoder by joint stereo processing via the segment list syntax.

After the assembling the TC data, all TCs are quantized in the same manner as the channel spectra of a Layer III stereo encoder using the iteration strategy described in ISO/IEC 11172-3, subclause C.1.5.4. The threshold values for the respective channel and scalefactorband which have been calculated by the psychoacoustic model are used as the iteration target (i.e. the maximum allowed distortion for each scalefactorband,  $x_{min}$ ). More sophisticated encoding strategies may involve the modification of the iteration targets according to the calculated threshold levels of other channels.

The allocation of bits among the coded TCs is done according to their relative contribution in terms of perceptual entropy (PE) as follows:

$$tc\_bits_{ch} = \frac{pe_{ch}}{\sum_i pe_i} \cdot total\_bits$$

where  $tc\_bits$  denotes the allocated bits for TC #ch,  $pe_i$  denotes the total perceptual entropy of channel number  $i$ , and  $total\_bits$  is the total available number of bits for this granule depending on bit-rate and sampling frequency. For the definition of the perceptual entropy see ISO/IEC 11172-3, subclause C.1.5.3 / 2.1.

### C.2.2.8 Multilingual extensions

The encoding is done, dependent on the `multi_lingual_fs` selected, as described in ISO 11172-3 or with the modifications described in subclause C.1.3

## Annex D

(Informative)

### Psychoacoustic models

#### D.1 Psychoacoustic Model 1 for Lower Sampling Frequencies

The necessary adaptations to psychoacoustic model 1 for the extension to lower sampling frequencies are small. A description of that psychoacoustic model is repeated here, with the necessary changes.

The calculation of the psychoacoustic model has to be adapted to the corresponding layer. The example presented here is valid for Layers I and II. The model can be adapted to Layer III.

There is no principal difference in the application of psychoacoustic model 1 to Layer I or II.

Layer I: A new bit allocation is calculated for each block of 12 subband or 384 input PCM samples.

Layer II: A new bit allocation is calculated for three blocks totalling 36 subband samples corresponding to 3\*384 (1 152) input PCM samples.

The bit allocation of the 32 subbands is calculated on the basis of the signal-to-mask ratios of all the subbands. Therefore, it is necessary to determine for each subband, the maximum signal level and the minimum masking threshold. The minimum masking threshold is derived from an FFT of the input PCM signal, followed by a psychoacoustic model calculation.

The FFT performed in parallel with the subband filter operation compensates for the lack of spectral selectivity obtained at low frequencies by the subband filterbank. This technique provides both a sufficient time resolution for the coded audio signal (Polyphase filter with optimised window for minimal pre-echoes) and a sufficient spectral resolution for the calculation of the masking thresholds. The frequencies and levels of aliasing distortions can be calculated. This is necessary for calculating a minimum bitrate for those subbands which need some bits to cancel the aliasing components in the decoder. The additional complexity to calculate the better frequency resolution is necessary only in the encoder, and introduces no additional delay or complexity in the decoder.

The calculation of the signal-to-mask-ratio is based on the following steps:

Step 1

- Calculation of the FFT for time to frequency conversion.

Step 2

- Determination of the sound pressure level in each subband.

Step 3

- Determination of the threshold in quiet (absolute threshold).

Step 4

- Finding of the tonal (more sinusoid-like) and non-tonal (more noise-like) components of the audio signal.

Step 5

- Decimation of the maskers, to obtain only the relevant maskers.

Step 6

- Calculation of the individual masking thresholds.

Step 7

- Determination of the global masking threshold.

Step 8

- Determination of the minimum masking threshold in each subband.

## Step 9

- Calculation of the signal-to-mask ratio in each subband.

These steps will be further discussed. A sampling frequency of 24 kHz is assumed, unless stated otherwise. For the other two sampling frequencies all frequencies mentioned should be scaled accordingly.

**Step 1 Calculation of spectrum**

The FFT is in principle the same as in ISO/IEC 11172-3, but due to the different sampling frequency the length when expressed in ms is different.

Technical data of the FFT:

	Layer I	Layer II
- transform length N	512 samples	1024 samples
Window size if Fs = 24 kHz	21,33 ms	42,67 ms
Window size if Fs = 22,05 kHz	23,22 ms	46,44 ms
Window size if Fs = 16 kHz	32 ms	64 ms
- Frequency resolution	Fs / 512	Fs / 1024

- Hann window,  $h(i)$ :

$$h(i) = \sqrt{8/3} * 0,5 * \{1 - \cos[2\pi (i)/N]\} \quad 0 \leq i \leq N-1$$

- power density spectrum  $X(k)$ :

$$X(k) = 10 * \log_{10} \left| \frac{1}{N} \sum_{l=0}^{N-1} h(l) * s(l) * e^{-jk l * 2\pi/N} \right|^2 \quad \text{dB} \quad k = 0 \dots N/2,$$

where  $s(l)$  is the input signal.

A normalisation to the reference level of 96 dB SPL (Sound Pressure Level) has to be done in such a way that the maximum value corresponds to 96 dB.

**Step 2 Determination of the sound pressure level**

The sound pressure level  $L_{sb}$  in subband  $n$  is computed by:

$$L_{sb}(n) = \text{MAX} [ X(k), 20 * \log(\text{scf}_{\text{max}}(n) * 32 \text{ 768}) - 10 ] \text{ dB}$$

$X(k)$  in subband  $n$

where  $X(k)$  is the sound pressure level of the spectral line with index  $k$  of the FFT with the maximum amplitude in the frequency range corresponding to subband  $n$ . The expression  $\text{scf}_{\text{max}}(n)$  is in Layer I the scalefactor, and in Layer II the maximum of the three scalefactors of subband  $n$  within a frame. The "-10 dB" term corrects for the difference between peak and RMS level. The sound pressure level  $L_{sb}(n)$  is computed for every subband  $n$ .

The following alternative method of calculating  $L_{sb}(n)$  offers a potential for better encoder performance, but this technique has not been subjected to a formal audio quality test.

The alternative sound pressure level  $L_{sb}$  in subband  $n$  is computed by:

$$L_{sb}(n) = \text{MAX} [ X_{\text{sp}}(n), 20 * \log(\text{scf}_{\text{max}}(n) * 32 \text{ 768}) - 10 ] \text{ dB}$$

with

$$X_{\text{sp}}(n) = 10 * \log_{10} \left( \sum 10^{X(k)/10} \right) \text{ dB}$$

k

k in subband n

where  $X_{\text{sp}l}(n)$  is the alternative sound pressure level corresponding to subband n.

### Step 3 Considering the threshold in quiet

The threshold in quiet  $LT_q(k)$ , also called absolute threshold, is available in the tables "Frequencies, critical band rates and absolute threshold" (tables D.1a, D.1b, D.1c for Layer I; tables D.1d, D.1e, D.1f for Layer II). These tables depend on the sampling rate of the input PCM signal. Values are available for each sample in the frequency domain where the masking threshold is calculated.

### Step 4 Finding of tonal and non-tonal components

The tonality of a masking component has an influence on the masking threshold. For this reason, it is worthwhile to discriminate between tonal and non-tonal components. For calculating the global masking threshold, it is necessary to derive the tonal and the non-tonal components from the FFT spectrum.

This step starts with the determination of local maxima, then extracts tonal components (sinusoids) and calculates the intensity of the non-tonal components within a bandwidth of a critical band. The boundaries of the critical bands are given in the tables "Critical band boundaries" (tables D.2a, D.2b, D.2c for Layer I; tables D.2d, D.2e, D.2f for Layer II).

The bandwidth of the critical bands varies with the centre frequency with a bandwidth of about only 0,1 kHz at low frequencies and with a bandwidth of about 4 kHz at high frequencies. It is known from psychoacoustic experiments that the ear has a better frequency resolution in the lower than in the higher frequency region. To determine if a local maximum may be a tonal component, a frequency range  $df$  around the local maximum is examined. The frequency range  $df$  is given by:

Sampling rate: 16 kHz

$df = 62,5 \text{ Hz}$	$0 \text{ kHz} < f \leq$	$3,0 \text{ kHz}$
$df = 93,75 \text{ Hz}$	$3,0 \text{ kHz} < f \leq$	$6,0 \text{ kHz}$
$df = 187,5 \text{ Hz}$	$6,0 \text{ kHz} < f \leq$	$7,5 \text{ kHz}$

Sampling rate: 22,05 kHz

$df = 86,133 \text{ Hz}$	$0 \text{ kHz} < f \leq$	$2,756 \text{ kHz}$
$df = 129,199 \text{ Hz}$	$2,756 \text{ kHz} < f \leq$	$5,512 \text{ kHz}$
$df = 258,398 \text{ Hz}$	$5,512 \text{ kHz} < f \leq$	$10,336 \text{ kHz}$

Sampling rate: 24 kHz

$df = 93,750 \text{ Hz}$	$0 \text{ kHz} < f \leq$	$3,0 \text{ kHz}$
$df = 140,63 \text{ Hz}$	$3,0 \text{ kHz} < f \leq$	$6,0 \text{ kHz}$
$df = 281,25 \text{ Hz}$	$6,0 \text{ kHz} < f \leq$	$11,250 \text{ kHz}$

To make lists of the spectral lines  $X(k)$  that are tonal or non-tonal, the following three operations are performed:

#### a) Labelling of local maxima

A spectral line  $X(k)$  is labelled as a local maximum if

$$X(k) > X(k-1) \quad \text{and} \quad X(k) \geq X(k+1)$$

#### b) Listing of tonal components and calculation of the sound pressure level

A local maximum is put in the list of tonal components if

$$X(k) - X(k+j) \geq 7 \text{ dB},$$

where  $j$  is chosen according to

Layer I,  $F_s=16$  kHz:

$$\begin{array}{ll} j = -2, +2 & \text{for } 2 < k < 96 \\ j = -3, -2, +2, +3 & \text{for } 96 \leq k < 192 \\ j = -6, \dots, -2, +2, \dots, +6 & \text{for } 192 \leq k < 250 \end{array}$$

Layer II,  $F_s=16$  kHz:

$$\begin{array}{ll} j = -4, +4 & \text{for } 4 < k < 192 \\ j = -6, \dots, -2, +2, \dots, +6 & \text{for } 192 \leq k < 384 \\ j = -12, \dots, -2, +2, \dots, +12 & \text{for } 384 \leq k < 500 \end{array}$$

Layer I,  $F_s=22,05, 24$  kHz:

$$\begin{array}{ll} j = -2, +2 & \text{for } 2 < k < 64 \\ j = -3, -2, +2, +3 & \text{for } 64 \leq k < 128 \\ j = -6, \dots, -2, +2, \dots, +6 & \text{for } 128 \leq k < 250 \end{array}$$

Layer II,  $F_s=22,05, 24$  kHz:

$$\begin{array}{ll} j = -4, +4 & \text{for } 4 < k < 128 \\ j = -6, \dots, -2, +2, \dots, +6 & \text{for } 128 \leq k < 256 \\ j = -12, \dots, -2, +2, \dots, +12 & \text{for } 256 \leq k < 500 \end{array}$$

If  $X(k)$  is found to be a tonal component, then the following parameters are listed:

- Index number  $k$  of the spectral line.
- Sound pressure level  $X_{tm}(k) = 10 * \log_{10} \left\{ 10^{\frac{X(k-1)}{10}} + 10^{\frac{X(k)}{10}} + 10^{\frac{X(k+1)}{10}} \right\}$ , in dB
- Tonal flag.

Next, all spectral lines within the examined frequency range are set to  $-\infty$  dB.

### c) Listing of non-tonal components and calculation of the power

The non-tonal (noise) components are calculated from the remaining spectral lines. To calculate the non-tonal components from these spectral lines  $X(k)$ , the critical bands  $z(k)$  are determined using the tables, "Critical band boundaries" (tables D.2a, D.2b, D.2c for Layer I; tables D.2d, D.2e, D.2f for Layer II). 21 critical bands are used for the sampling rate of 16 kHz, 23 critical bands are used for 22,05 kHz and 24 kHz. Within each critical band, the power of the spectral lines (remaining after the tonal components have been zeroed) are summed to form the sound pressure level of the new non-tonal component  $X_{nm}(k)$  corresponding to that critical band.

The following parameters are listed:

- Index number  $k$  of the spectral line nearest to the geometric mean of the critical band.
- Sound pressure level  $X_{nm}(k)$  in dB.
- Non-tonal flag.

## Step 5 Decimation of tonal and non-tonal masking components

Decimation is a procedure that is used to reduce the number of maskers which are considered for the calculation of the global masking threshold.

- a) Tonal  $X_{tm}(k)$  or non-tonal components  $X_{nm}(k)$  are considered for the calculation of the masking threshold only if:

$$X_{tm}(k) \geq LT_q(k) \quad \text{or} \quad X_{nm}(k) \geq LT_q(k)$$

In this expression,  $LT_q(k)$  is the absolute threshold (or threshold in quiet) at the frequency of index  $k$ . These values are given in tables D.1a, D.1b, D.1c for Layer I; tables D.1d, D.1e, D.1f for Layer II.

- b) Decimation of two or more tonal components within a distance of less than 0,5 Bark: Keep the component with the highest power, and remove the smaller component(s) from the list of tonal components. For this operation, a sliding window in the critical band domain is used with a width of 0,5 Bark.

In the following, the index  $j$  is used to indicate the relevant tonal or non-tonal masking components from the combined decimated list.

### Step 6 Calculation of individual masking thresholds

Of the original  $N/2$  frequency domain samples, indexed by  $k$ , only a subset of the samples, indexed by  $i$ , are considered for the global masking threshold calculation. The samples used are shown in tables D.1a, D.1b, D.1c for Layer I; tables D.1d, D.1e, D.1f for Layer II.

Layer I:

For the frequency lines corresponding to the frequency region which is covered by the first six subbands no subsampling is used. For the frequency region corresponding to the next six subbands every second spectral line is considered. Finally, every fourth spectral line is considered for the next 18 subbands (see also tables D.1a, D.1b, D.1c for Layer I).

Layer II:

For the frequency lines corresponding to the frequency region which is covered by the first three subbands no subsampling is used. For the frequency region which is covered by next three subbands every second spectral line is considered. For the frequency region corresponding to the next six subbands every fourth spectral line is considered. Finally, every eighth spectral line is considered for the next 18 subbands (See also tables D.1d, D.1e, D.1f for Layer II).

The number of samples,  $n$ , in the subsampled frequency domain depends on the layer. For Layer I,  $n$  equals 108, for Layer II,  $n$  equals 132.

Every tonal and non-tonal component is assigned the value of the index  $i$  that most closely corresponds to the frequency of the original spectral line  $X(k)$ . This index  $i$  is given in tables D.1a, D.1b, D.1c for Layer I; tables D.1d, D.1e, D.1f for Layer II.

The individual masking thresholds of both tonal and non-tonal components are given by the following expression:

$$\begin{aligned} LT_{tm}[z(j),z(i)] &= X_{tm}[z(j)] + av_{tm}[z(j)] + vf[z(j),z(i)] \text{ dB} \\ LT_{nm}[z(j),z(i)] &= X_{nm}[z(j)] + av_{nm}[z(j)] + vf[z(j),z(i)] \text{ dB} \end{aligned}$$

In this formula,  $LT_{tm}$  and  $LT_{nm}$  are the individual masking thresholds at critical band rate  $z$  in Bark of the masking component at the critical band rate of the masker  $z_m$  in Bark. The values in dB can be either positive or negative. The term  $X_{tm}[z(j)]$  is the sound pressure level of the masking component with the index number  $j$  at the corresponding critical band rate  $z(j)$ . The term  $av$  is called the masking index and  $vf$  the masking function of the masking component  $X_{tm}[z(j)]$ . The masking index  $av$  is different for tonal and non-tonal maskers ( $av_{tm}$  and  $av_{nm}$ ).

For tonal maskers, it is given by

$$av_{tm} = -1,525 - 0,275 * z(j) - 4,5 \text{ dB},$$

and for non-tonal maskers

$$av_{nm} = -1,525 - 0,175 * z(j) - 0,5 \text{ dB}.$$



The masking function  $vf$  of a masker is characterised by different lower and upper slopes, which depend on the distance in Bark  $dz = z(i) - z(j)$  to the masker. In this expression  $i$  is the index of the spectral line at which the masking function is calculated and  $j$  that of the masker. The critical band rates  $z(j)$  and  $z(i)$  can be found in tables D.1a, D.1b, D.1c for Layer I; tables D.1d, D.1e, D.1f for Layer II. The masking function, which is the same for tonal and non-tonal maskers, is given by:

$$\begin{aligned} vf &= 17 * (dz + 1) - (0,4 * X[z(j)] + 6) \text{ dB} && \text{for } -3 \leq dz < -1 \text{ Bark} \\ vf &= (0,4 * X[z(j)] + 6) * dz \text{ dB} && \text{for } -1 \leq dz < 0 \text{ Bark} \\ vf &= -17 * dz \text{ dB} && \text{for } 0 \leq dz < 1 \text{ Bark} \\ vf &= -(dz - 1) * (17 - 0,15 * X[z(j)]) - 17 \text{ dB} && \text{for } 1 \leq dz < 8 \text{ Bark} \end{aligned}$$

In these expressions  $X[z(j)]$  is the sound pressure level of the  $j^{\text{th}}$  masking component in dB. For reasons of implementation complexity, the masking is no longer considered if  $dz < -3$  Bark, or  $dz \geq 8$  Bark ( $LT_{tm}$  and  $LT_{nm}$  are set to  $-\infty$  dB outside this range).

### Step 7 Calculation of the global masking threshold $LT_g$

The global masking threshold  $LT_g(i)$  at the  $i^{\text{th}}$  frequency sample is derived from the upper and lower slopes of the individual masking thresholds of each of the  $j$  tonal and non-tonal maskers and from the threshold in quiet  $LT_q(i)$ . This is also given in tables D.1a, D.1b, D.1c for Layer I; tables D.1d, D.1e, D.1f for Layer II. The global masking threshold is found by summing the powers corresponding to the individual masking thresholds and the threshold in quiet.

$$LT_g(i) = 10 \log_{10} \left( 10^{LT_q(i)/10} + \sum_{j=1}^m 10^{LT_{tm}(z(j),z(i))/10} + \sum_{j=1}^n 10^{LT_{nm}(z(j),z(i))/10} \right)$$

The total number of tonal maskers is given by  $m$ , and the total number of non-tonal maskers is given by  $n$ . For a given  $i$ , the range of  $j$  can be reduced to just encompass those masking components that are within  $-8$  to  $+3$  Bark from  $i$ . Outside of this range  $LT_{tm}$  and  $LT_{nm}$  are  $-\infty$  dB.

### Step 8 Determination of the minimum masking threshold

The minimum masking level  $LT_{min}(n)$  in subband  $n$  is determined by the following expression:

$$LT_{min}(n) = \text{MIN}[ LT_g(i) ] \text{ dB}$$

$f(i)$  in subband  $n$

where  $f(i)$  is the frequency of the  $i^{\text{th}}$  frequency sample. The  $f(i)$  are tabulated in tables D.1a, D.1b, D.1c for Layer I; tables D.1d, D.1e, D.1f for Layer II. A minimum masking level  $LT_{min}(n)$  is computed for every subband.

### Step 9 Calculation of the signal-to-mask-ratio

The signal-to-mask ratio

$$SMR_{sb}(n) = L_{sb}(n) - LT_{min}(n) \text{ dB}$$

is computed for every subband  $n$ .

**Table D.1a. - Frequencies, critical band rates and absolute threshold**

Table is valid for Layer I at a sampling rate of 16 kHz.

Index Number i	Frequency [Hz]	Crit.Band Rate [z]	Absolute Thresh. [dB]	Index Number i	Frequency [Hz]	Crit.Band Rate [z]	Absolute Thresh. [dB]
1	31,25	0,309	58,23	55	1937,50	12,898	0,02
2	62,50	0,617	33,44	56	2000,00	13,104	-0,25
3	93,75	0,925	24,17	57	2062,50	13,302	-0,54
4	125,00	1,232	19,20	58	2125,00	13,493	-0,83
5	156,25	1,538	16,05	59	2187,50	13,678	-1,12
6	187,50	1,842	13,87	60	2250,00	13,855	-1,43
7	218,75	2,145	12,26	61	2312,50	14,027	-1,73
8	250,00	2,445	11,01	62	2375,00	14,193	-2,04
9	281,25	2,742	10,01	63	2437,50	14,354	-2,34
10	312,50	3,037	9,20	64	2500,00	14,509	-2,64
11	343,75	3,329	8,52	65	2562,50	14,660	-2,93
12	375,00	3,618	7,94	66	2625,00	14,807	-3,22
13	406,25	3,903	7,44	67	2687,50	14,949	-3,49
14	437,50	4,185	7,00	68	2750,00	15,087	-3,74
15	468,75	4,463	6,62	69	2812,50	15,221	-3,98
16	500,00	4,736	6,28	70	2875,00	15,351	-4,20
17	531,25	5,006	5,97	71	2937,50	15,478	-4,40
18	562,50	5,272	5,70	72	3000,00	15,602	-4,57
19	593,75	5,533	5,44	73	3125,00	15,841	-4,82
20	625,00	5,789	5,21	74	3250,00	16,069	-4,96
21	656,25	6,041	5,00	75	3375,00	16,287	-4,98
22	687,50	6,289	4,80	76	3500,00	16,496	-4,90
23	718,75	6,532	4,62	77	3625,00	16,697	-4,70
24	750,00	6,770	4,45	78	3750,00	16,891	-4,39
25	781,25	7,004	4,29	79	3875,00	17,078	-3,99
26	812,50	7,233	4,14	80	4000,00	17,259	-3,51
27	843,75	7,457	4,00	81	4125,00	17,434	-2,99
28	875,00	7,677	3,86	82	4250,00	17,605	-2,45
29	906,25	7,892	3,73	83	4375,00	17,770	-1,90
30	937,50	8,103	3,61	84	4500,00	17,932	-1,37
31	968,75	8,309	3,49	85	4625,00	18,089	-0,86
32	1000,00	8,511	3,37	86	4750,00	18,242	-0,39
33	1031,25	8,708	3,26	87	4875,00	18,392	0,03
34	1062,50	8,901	3,15	88	5000,00	18,539	0,40
35	1093,75	9,090	3,04	89	5125,00	18,682	0,72
36	1125,00	9,275	2,93	90	5250,00	18,823	1,00
37	1156,25	9,456	2,83	91	5375,00	18,960	1,24
38	1187,50	9,632	2,73	92	5500,00	19,095	1,44
39	1218,75	9,805	2,63	93	5625,00	19,226	1,62
40	1250,00	9,974	2,53	94	5750,00	19,356	1,78
41	1281,25	10,139	2,42	95	5875,00	19,482	1,92
42	1312,50	10,301	2,32	96	6000,00	19,606	2,05
43	1343,75	10,459	2,22	97	6125,00	19,728	2,18
44	1375,00	10,614	2,12	98	6250,00	19,847	2,30
45	1406,25	10,765	2,02	99	6375,00	19,964	2,42
46	1437,50	10,913	1,92	100	6500,00	20,079	2,55
47	1468,75	11,058	1,81	101	6625,00	20,191	2,69
48	1500,00	11,199	1,71	102	6750,00	20,300	2,82
49	1562,50	11,474	1,49	103	6875,00	20,408	2,97
50	1625,00	11,736	1,27	104	7000,00	20,513	3,13
51	1687,50	11,988	1,04	105	7125,00	20,616	3,29
52	1750,00	12,230	0,80	106	7250,00	20,717	3,46
53	1812,50	12,461	0,55	107	7375,00	20,815	3,65
54	1875,00	12,684	0,29	108	7500,00	20,912	3,84

**Table D.1b. - Frequencies, critical band rates and absolute threshold**

Table is valid for Layer I at a sampling rate of 22,05 kHz.

Index Number i	Frequency [Hz]	Crit.Band Rate [z]	Absolute Thresh. [dB]	Index Number i	Frequency [Hz]	Crit.Band Rate [z]	Absolute Thresh. [dB]
1	43,07	0,425	45,05	55	2670,12	14,909	-3,41
2	86,13	0,850	25,87	56	2756,25	15,100	-3,77
3	129,20	1,273	18,70	57	2842,38	15,284	-4,09
4	172,27	1,694	14,85	58	2928,52	15,460	-4,37
5	215,33	2,112	12,41	59	3014,65	15,631	-4,60
6	258,40	2,525	10,72	60	3100,78	15,796	-4,78
7	301,46	2,934	9,47	61	3186,91	15,955	-4,91
8	344,53	3,337	8,50	62	3273,05	16,110	-4,97
9	387,60	3,733	7,73	63	3359,18	16,260	-4,98
10	430,66	4,124	7,10	64	3445,31	16,406	-4,96
11	473,73	4,507	6,56	65	3531,45	16,547	-4,88
12	516,80	4,882	6,11	66	3617,58	16,685	-4,74
13	559,86	5,249	5,72	67	3703,71	16,820	-4,54
14	602,93	5,608	5,37	68	3789,84	16,951	-4,30
15	646,00	5,959	5,07	69	3875,98	17,079	-4,02
16	689,06	6,301	4,79	70	3962,11	17,205	-3,71
17	732,13	6,634	4,55	71	4048,24	17,327	-3,37
18	775,20	6,959	4,32	72	4134,38	17,447	-3,00
19	818,26	7,274	4,11	73	4306,64	17,680	-2,25
20	861,33	7,581	3,92	74	4478,91	17,905	-1,50
21	904,39	7,879	3,74	75	4651,17	18,121	-0,81
22	947,46	8,169	3,57	76	4823,44	18,331	-0,18
23	990,53	8,450	3,40	77	4995,70	18,534	0,35
24	1033,59	8,723	3,25	78	5167,97	18,731	0,79
25	1076,66	8,987	3,10	79	5340,23	18,922	1,15
26	1119,73	9,244	2,95	80	5512,50	19,108	1,44
27	1162,79	9,493	2,81	81	5684,77	19,289	1,68
28	1205,86	9,734	2,67	82	5857,03	19,464	1,89
29	1248,93	9,968	2,53	83	6029,30	19,635	2,07
30	1291,99	10,195	2,39	84	6201,56	19,801	2,24
31	1335,06	10,416	2,25	85	6373,83	19,963	2,41
32	1378,13	10,629	2,11	86	6546,09	20,120	2,59
33	1421,19	10,836	1,97	87	6718,36	20,273	2,78
34	1464,26	11,037	1,83	88	6890,63	20,421	2,98
35	1507,32	11,232	1,68	89	7062,89	20,565	3,19
36	1550,39	11,421	1,53	90	7235,16	20,705	3,43
37	1593,46	11,605	1,38	91	7407,42	20,840	3,68
38	1636,52	11,783	1,23	92	7579,69	20,972	3,95
39	1679,59	11,957	1,07	93	7751,95	21,099	4,24
40	1722,66	12,125	0,90	94	7924,22	21,222	4,56
41	1765,72	12,289	0,74	95	8096,48	21,342	4,89
42	1808,79	12,448	0,56	96	8268,75	21,457	5,25
43	1851,86	12,603	0,39	97	8441,02	21,569	5,64
44	1894,92	12,753	0,21	98	8613,28	21,677	6,05
45	1937,99	12,900	0,02	99	8785,55	21,781	6,48
46	1981,05	13,042	-0,17	100	8957,81	21,882	6,95
47	2024,12	13,181	-0,36	101	9130,08	21,980	7,44
48	2067,19	13,317	-0,56	102	9302,34	22,074	7,96
49	2153,32	13,578	-0,96	103	9474,61	22,165	8,52
50	2239,45	13,826	-1,38	104	9646,88	22,253	9,10
51	2325,59	14,062	-1,79	105	9819,14	22,338	9,72
52	2411,72	14,288	-2,21	106	9991,41	22,420	10,37
53	2497,85	14,504	-2,63	107	10 163,67	22,499	11,06
54	2583,98	14,711	-3,03	108	10 335,94	22,576	11,79

**Table D.1c. - Frequencies, critical band rates and absolute threshold**

Table is valid for Layer I at a sampling rate of 24 kHz.

Index Number i	Frequency [Hz]	Crit.Band Rate [z]	Absolute Thresh. [dB]	Index Number i	Frequency [Hz]	Crit.Band Rate [z]	Absolute Thresh. [dB]
1	46,88	0,463	42,10	55	2906,25	15,415	-4,30
2	93,75	0,925	24,17	56	3000,00	15,602	-4,57
3	140,63	1,385	17,47	57	3093,75	15,783	-4,77
4	187,50	1,842	13,87	58	3187,50	15,956	-4,91
5	234,38	2,295	11,60	59	3281,25	16,124	-4,98
6	281,25	2,742	10,01	60	3375,00	16,287	-4,98
7	328,13	3,184	8,84	61	3468,75	16,445	-4,94
8	375,00	3,618	7,94	62	3562,50	16,598	-4,84
9	421,88	4,045	7,22	63	3656,25	16,746	-4,66
10	468,75	4,463	6,62	64	3750,00	16,891	-4,43
11	515,63	4,872	6,12	65	3843,75	17,032	-4,15
12	562,50	5,272	5,70	66	3937,50	17,169	-3,82
13	609,38	5,661	5,33	67	4031,25	17,303	-3,45
14	656,25	6,041	5,00	68	4125,00	17,434	-3,06
15	703,13	6,411	4,71	69	4218,75	17,563	-2,66
16	750,00	6,770	4,45	70	4312,50	17,688	-2,24
17	796,88	7,119	4,21	71	4406,25	17,811	-1,83
18	843,75	7,457	4,00	72	4500,00	17,932	-1,43
19	890,63	7,785	3,79	73	4687,50	18,166	-0,68
20	937,50	8,103	3,61	74	4875,00	18,392	-0,02
21	984,38	8,410	3,43	75	5062,50	18,611	0,52
22	1031,25	8,708	3,26	76	5250,00	18,823	0,97
23	1078,13	8,996	3,09	77	5437,50	19,028	1,32
24	1125,00	9,275	2,93	78	5625,00	19,226	1,60
25	1171,88	9,544	2,78	79	5812,50	19,419	1,83
26	1218,75	9,805	2,63	80	6000,00	19,606	2,03
27	1265,63	10,057	2,47	81	6187,50	19,788	2,22
28	1312,50	10,301	2,32	82	6375,00	19,964	2,41
29	1359,38	10,537	2,17	83	6562,50	20,135	2,60
30	1406,25	10,765	2,02	84	6750,00	20,300	2,81
31	1453,13	10,986	1,86	85	6937,50	20,461	3,03
32	1500,00	11,199	1,71	86	7125,00	20,616	3,27
33	1546,88	11,406	1,55	87	7312,50	20,766	3,53
34	1593,75	11,606	1,38	88	7500,00	20,912	3,82
35	1640,63	11,800	1,21	89	7687,50	21,052	4,12
36	1687,50	11,988	1,04	90	7875,00	21,188	4,46
37	1734,38	12,170	0,86	91	8062,50	21,318	4,82
38	1781,25	12,347	0,67	92	8250,00	21,445	5,20
39	1828,13	12,518	0,49	93	8437,50	21,567	5,62
40	1875,00	12,684	0,29	94	8625,00	21,684	6,07
41	1921,88	12,845	0,09	95	8812,50	21,797	6,54
42	1968,75	13,002	-0,11	96	9000,00	21,906	7,06
43	2015,63	13,154	-0,32	97	9187,50	22,012	7,60
44	2062,50	13,302	-0,54	98	9375,00	22,113	8,18
45	2109,38	13,446	-0,75	99	9562,50	22,210	8,80
46	2156,25	13,586	-0,97	100	9750,00	22,304	9,46
47	2203,13	13,723	-1,20	101	9937,50	22,395	10,15
48	2250,00	13,855	-1,43	102	10 125,00	22,482	10,89
49	2343,75	14,111	-1,88	103	10 312,50	22,566	11,67
50	2437,50	14,354	-2,34	104	10 500,00	22,646	12,50
51	2531,25	14,585	-2,79	105	10 687,50	22,724	13,37
52	2625,00	14,807	-3,22	106	10 875,00	22,799	14,29
53	2718,75	15,018	-3,62	107	11 062,50	22,871	15,26
54	2812,50	15,221	-3,98	108	11 250,00	22,941	16,28

**Table D.1d. - Frequencies, critical band rates and absolute threshold**

Table is valid for Layer II at a sampling rate of 16 kHz.

Index Number i	Frequency [Hz]	Crit.Band Rate [z]	Absolute Thresh. [dB]	Index Number i	Frequency [Hz]	Crit.Band Rate [z]	Absolute Thresh. [dB]
1	15,63	0,154	68,00	67	1343,75	10,459	2,22
2	31,25	0,309	58,23	68	1375,00	10,614	2,12
3	46,88	0,463	42,10	69	1406,25	10,765	2,02
4	62,50	0,617	33,44	70	1437,50	10,913	1,92
5	78,13	0,771	27,97	71	1468,75	11,058	1,81
6	93,75	0,925	24,17	72	1500,00	11,199	1,71
7	109,38	1,079	21,36	73	1562,50	11,474	1,49
8	125,00	1,232	19,20	74	1625,00	11,736	1,27
9	140,63	1,385	17,47	75	1687,50	11,988	1,04
10	156,25	1,538	16,05	76	1750,00	12,230	0,80
11	171,88	1,690	14,87	77	1812,50	12,461	0,55
12	187,50	1,842	13,87	78	1875,00	12,684	0,29
13	203,13	1,994	13,01	79	1937,50	12,898	0,02
14	218,75	2,145	12,26	80	2000,00	13,104	-0,25
15	234,38	2,295	11,60	81	2062,50	13,302	-0,54
16	250,00	2,445	11,01	82	2125,00	13,493	-0,83
17	265,63	2,594	10,49	83	2187,50	13,678	-1,12
18	281,25	2,742	10,01	84	2250,00	13,855	-1,43
19	296,88	2,890	9,59	85	2312,50	14,027	-1,73
20	312,50	3,037	9,20	86	2375,00	14,193	-2,04
21	328,13	3,184	8,84	87	2437,50	14,354	-2,34
22	343,75	3,329	8,52	88	2500,00	14,509	-2,64
23	359,38	3,474	8,22	89	2562,50	14,660	-2,93
24	375,00	3,618	7,94	90	2625,00	14,807	-3,22
25	390,63	3,761	7,68	91	2687,50	14,949	-3,49
26	406,25	3,903	7,44	92	2750,00	15,087	-3,74
27	421,88	4,045	7,22	93	2812,50	15,221	-3,98
28	437,50	4,185	7,00	94	2875,00	15,351	-4,20
29	453,13	4,324	6,81	95	2937,50	15,478	-4,40
30	468,75	4,463	6,62	96	3000,00	15,602	-4,57
31	484,38	4,600	6,44	97	3125,00	15,841	-4,82
32	500,00	4,736	6,28	98	3250,00	16,069	-4,96
33	515,63	4,872	6,12	99	3375,00	16,287	-4,98
34	531,25	5,006	5,97	100	3500,00	16,496	-4,88
35	546,88	5,139	5,83	101	3625,00	16,697	-4,66
36	562,50	5,272	5,70	102	3750,00	16,891	-4,34
37	578,13	5,403	5,57	103	3875,00	17,078	-3,93
38	593,75	5,533	5,44	104	4000,00	17,259	-3,45
39	609,38	5,661	5,33	105	4125,00	17,434	-2,93
40	625,00	5,789	5,21	106	4250,00	17,605	-2,38
41	640,63	5,916	5,10	107	4375,00	17,770	-1,83
42	656,25	6,041	5,00	108	4500,00	17,932	-1,30
43	671,88	6,166	4,90	109	4625,00	18,089	-0,80
44	687,50	6,289	4,80	110	4750,00	18,242	-0,34
45	703,13	6,411	4,71	111	4875,00	18,392	0,07
46	718,75	6,532	4,62	112	5000,00	18,539	0,44
47	734,38	6,651	4,53	113	5125,00	18,682	0,76
48	750,00	6,770	4,45	114	5250,00	18,823	1,03
49	781,25	7,004	4,29	115	5375,00	18,960	1,26
50	812,50	7,233	4,14	116	5500,00	19,095	1,47
51	843,75	7,457	4,00	117	5625,00	19,226	1,64
52	875,00	7,677	3,86	118	5750,00	19,356	1,80
53	906,25	7,892	3,73	119	5875,00	19,482	1,94
54	937,50	8,103	3,61	120	6000,00	19,606	2,07
55	968,75	8,309	3,49	121	6125,00	19,728	2,19
56	1000,00	8,511	3,37	122	6250,00	19,847	2,32
57	1031,25	8,708	3,26	123	6375,00	19,964	2,44
58	1062,50	8,901	3,15	124	6500,00	20,079	2,57
59	1093,75	9,090	3,04	125	6625,00	20,191	2,70
60	1125,00	9,275	2,93	126	6750,00	20,300	2,84

61	1156,25	9,456	2,83	127	6875,00	20,408	2,99
62	1187,50	9,632	2,73	128	7000,00	20,513	3,15
63	1218,75	9,805	2,63	129	7125,00	20,616	3,31
64	1250,00	9,974	2,53	130	7250,00	20,717	3,49
65	1281,25	10,139	2,42	131	7375,00	20,815	3,67
66	1312,50	10,301	2,32	132	7500,00	20,912	3,87

**Table D.1e. - Frequencies, critical band rates and absolute threshold**

Table is valid for Layer II at a sampling rate of 22,05 kHz.

Index Number i	Frequency [Hz]	Crit.Band Rate [z]	Absolute Thresh. [dB]	Index Number i	Frequency [Hz]	Crit.Band Rate [z]	Absolute Thresh. [dB]
1	21,53	0,213	68,00	67	1851,86	12,603	0,39
2	43,07	0,425	45,05	68	1894,92	12,753	0,21
3	64,60	0,638	32,57	69	1937,99	12,900	0,02
4	86,13	0,850	25,87	70	1981,05	13,042	-0,17
5	107,67	1,062	21,63	71	2024,12	13,181	-0,36
6	129,20	1,273	18,70	72	2067,19	13,317	-0,56
7	150,73	1,484	16,52	73	2153,32	13,578	-0,96
8	172,27	1,694	14,85	74	2239,45	13,826	-1,38
9	193,80	1,903	13,51	75	2325,59	14,062	-1,79
10	215,33	2,112	12,41	76	2411,72	14,288	-2,21
11	236,87	2,319	11,50	77	2497,85	14,504	-2,63
12	258,40	2,525	10,72	78	2583,98	14,711	-3,03
13	279,93	2,730	10,05	79	2670,12	14,909	-3,41
14	301,46	2,934	9,47	80	2756,25	15,100	-3,77
15	323,00	3,136	8,96	81	2842,38	15,284	-4,09
16	344,53	3,337	8,50	82	2928,52	15,460	-4,37
17	366,06	3,536	8,10	83	3014,65	15,631	-4,60
18	387,60	3,733	7,73	84	3100,78	15,796	-4,78
19	409,13	3,929	7,40	85	3186,91	15,955	-4,91
20	430,66	4,124	7,10	86	3273,05	16,110	-4,97
21	452,20	4,316	6,82	87	3359,18	16,260	-4,98
22	473,73	4,507	6,56	88	3445,31	16,406	-4,94
23	495,26	4,695	6,33	89	3531,45	16,547	-4,85
24	516,80	4,882	6,11	90	3617,58	16,685	-4,69
25	538,33	5,067	5,91	91	3703,71	16,820	-4,49
26	559,86	5,249	5,72	92	3789,84	16,951	-4,24
27	581,40	5,430	5,54	93	3875,98	17,079	-3,95
28	602,93	5,608	5,37	94	3962,11	17,205	-3,63
29	624,46	5,785	5,22	95	4048,24	17,327	-3,28
30	646,00	5,959	5,07	96	4134,38	17,447	-2,91
31	667,53	6,131	4,93	97	4306,64	17,680	-2,16
32	689,06	6,301	4,79	98	4478,91	17,905	-1,41
33	710,60	6,469	4,67	99	4651,17	18,121	-0,72
34	732,13	6,634	4,55	100	4823,44	18,331	-0,11
35	753,66	6,798	4,43	101	4995,70	18,534	0,41
36	775,20	6,959	4,32	102	5167,97	18,731	0,84
37	796,73	7,118	4,21	103	5340,23	18,922	1,19
38	818,26	7,274	4,11	104	5512,50	19,108	1,48
39	839,79	7,429	4,01	105	5684,77	19,289	1,71
40	861,33	7,581	3,92	106	5857,03	19,464	1,91
41	882,86	7,731	3,83	107	6029,30	19,635	2,09
42	904,39	7,879	3,74	108	6201,56	19,801	2,26
43	925,93	8,025	3,65	109	6373,83	19,963	2,43
44	947,46	8,169	3,57	110	6546,09	20,120	2,61
45	968,99	8,310	3,48	111	6718,36	20,273	2,80
46	990,53	8,450	3,40	112	6890,63	20,421	3,00
47	1012,06	8,587	3,33	113	7062,89	20,565	3,22
48	1033,59	8,723	3,25	114	7235,16	20,705	3,46
49	1076,66	8,987	3,10	115	7407,42	20,840	3,71
50	1119,73	9,244	2,95	116	7579,69	20,972	3,98
51	1162,79	9,493	2,81	117	7751,95	21,099	4,28
52	1205,86	9,734	2,67	118	7924,22	21,222	4,60
53	1248,93	9,968	2,53	119	8096,48	21,342	4,94
54	1291,99	10,195	2,39	120	8268,75	21,457	5,30
55	1335,06	10,416	2,25	121	8441,02	21,569	5,69
56	1378,13	10,629	2,11	122	8613,28	21,677	6,10
57	1421,19	10,836	1,97	123	8785,55	21,781	6,54
58	1464,26	11,037	1,83	124	8957,81	21,882	7,01
59	1507,32	11,232	1,68	125	9130,08	21,980	7,50
60	1550,39	11,421	1,53	126	9302,34	22,074	8,03

61	1593,46	11,605	1,38	127	9474,61	22,165	8,59
62	1636,52	11,783	1,23	128	9646,88	22,253	9,18
63	1679,59	11,957	1,07	129	9819,14	22,338	9,80
64	1722,66	12,125	0,90	130	9991,41	22,420	10,46
65	1765,72	12,289	0,74	131	10 163,67	22,499	11,15
66	1808,79	12,448	0,56	132	10 335,94	22,576	11,88



**Table D.1f. - Frequencies, critical band rates and absolute threshold**

Table is valid for Layer II at a sampling rate of 24 kHz.

Index Number i	Frequency [Hz]	Crit.Band Rate [z]	Absolute Thresh. [dB]	Index Number i	Frequency [Hz]	Crit.Band Rate [z]	Absolute Thresh. [dB]
1	23,44	0,232	68,00	67	2015,63	13,154	-0,32
2	46,88	0,463	42,10	68	2062,50	13,302	-0,54
3	70,31	0,694	30,43	69	2109,38	13,446	-0,75
4	93,75	0,925	24,17	70	2156,25	13,586	-0,97
5	117,19	1,156	20,22	71	2203,13	13,723	-1,20
6	140,63	1,385	17,47	72	2250,00	13,855	-1,43
7	164,06	1,614	15,44	73	2343,75	14,111	-1,88
8	187,50	1,842	13,87	74	2437,50	14,354	-2,34
9	210,94	2,069	12,62	75	2531,25	14,585	-2,79
10	234,38	2,295	11,60	76	2625,00	14,807	-3,22
11	257,81	2,519	10,74	77	2718,75	15,018	-3,62
12	281,25	2,742	10,01	78	2812,50	15,221	-3,98
13	304,69	2,964	9,39	79	2906,25	15,415	-4,30
14	328,13	3,184	8,84	80	3000,00	15,602	-4,57
15	351,56	3,402	8,37	81	3093,75	15,783	-4,77
16	375,00	3,618	7,94	82	3187,50	15,956	-4,91
17	398,44	3,832	7,56	83	3281,25	16,124	-4,98
18	421,88	4,045	7,22	84	3375,00	16,287	-4,98
19	445,31	4,255	6,90	85	3468,75	16,445	-4,92
20	468,75	4,463	6,62	86	3562,50	16,598	-4,80
21	492,19	4,668	6,36	87	3656,25	16,746	-4,61
22	515,63	4,872	6,12	88	3750,00	16,891	-4,36
23	539,06	5,073	5,90	89	3843,75	17,032	-4,07
24	562,50	5,272	5,70	90	3937,50	17,169	-3,73
25	585,94	5,468	5,50	91	4031,25	17,303	-3,36
26	609,38	5,661	5,33	92	4125,00	17,434	-2,96
27	632,81	5,853	5,16	93	4218,75	17,563	-2,55
28	656,25	6,041	5,00	94	4312,50	17,688	-2,14
29	679,69	6,227	4,85	95	4406,25	17,811	-1,73
30	703,13	6,411	4,71	96	4500,00	17,932	-1,33
31	726,56	6,592	4,58	97	4687,50	18,166	-0,59
32	750,00	6,770	4,45	98	4875,00	18,392	0,05
33	773,44	6,946	4,33	99	5062,50	18,611	0,58
34	796,88	7,119	4,21	100	5250,00	18,823	1,01
35	820,31	7,289	4,10	101	5437,50	19,028	1,36
36	843,75	7,457	4,00	102	5625,00	19,226	1,63
37	867,19	7,622	3,89	103	5812,50	19,419	1,86
38	890,63	7,785	3,79	104	6000,00	19,606	2,06
39	914,06	7,945	3,70	105	6187,50	19,788	2,25
40	937,50	8,103	3,61	106	6375,00	19,964	2,43
41	960,94	8,258	3,51	107	6562,50	20,135	2,63
42	984,38	8,410	3,43	108	6750,00	20,300	2,83
43	1007,81	8,560	3,34	109	6937,50	20,461	3,06
44	1031,25	8,708	3,26	110	7125,00	20,616	3,30
45	1054,69	8,853	3,17	111	7312,50	20,766	3,57
46	1078,13	8,996	3,09	112	7500,00	20,912	3,85
47	1101,56	9,137	3,01	113	7687,50	21,052	4,16
48	1125,00	9,275	2,93	114	7875,00	21,188	4,50
49	1171,88	9,544	2,78	115	8062,50	21,318	4,86
50	1218,75	9,805	2,63	116	8250,00	21,445	5,25
51	1265,63	10,057	2,47	117	8437,50	21,567	5,67
52	1312,50	10,301	2,32	118	8625,00	21,684	6,12
53	1359,38	10,537	2,17	119	8812,50	21,797	6,61
54	1406,25	10,765	2,02	120	9000,00	21,906	7,12
55	1453,13	10,986	1,86	121	9187,50	22,012	7,67
56	1500,00	11,199	1,71	122	9375,00	22,113	8,26
57	1546,88	11,406	1,55	123	9562,50	22,210	8,88
58	1593,75	11,606	1,38	124	9750,00	22,304	9,54
59	1640,63	11,800	1,21	125	9937,50	22,395	10,24
60	1687,50	11,988	1,04	126	10 125,00	22,482	10,98

61	1734,38	12,170	0,86	127	10 312,50	22,566	11,77
62	1781,25	12,347	0,67	128	10 500,00	22,646	12,60
63	1828,13	12,518	0,49	129	10 687,50	22,724	13,48
64	1875,00	12,684	0,29	130	10 875,00	22,799	14,41
65	1921,88	12,845	0,09	131	11 062,50	22,871	15,38
66	1968,75	13,002	-0,11	132	11 250,00	22,941	16,41

**Table D.2a. - Critical band boundaries**

This table is valid for Layer I at a sampling rate of 16 kHz.  
The frequencies represent the top end of each critical band.

no	index of Table F&CB	frequency [Hz]	Bark [z]
0	3	93,75	0,925
1	7	218,75	2,145
2	10	312,50	3,037
3	13	406,25	3,903
4	17	531,25	5,006
5	21	656,25	6,041
6	25	781,25	7,004
7	30	937,50	8,103
8	35	1093,75	9,090
9	40	1250,00	9,974
10	47	1468,75	11,058
11	51	1687,50	11,988
12	55	1937,50	12,898
13	61	2312,50	14,027
14	67	2687,50	14,949
15	74	3250,00	16,069
16	79	3875,00	17,078
17	84	4500,00	17,932
18	91	5375,00	18,960
19	99	6375,00	19,964
20	108	7500,00	20,912

**Table D.2b. - Critical band boundaries**

This table is valid for Layer I at a sampling rate of 22,05 kHz.  
The frequencies represent the top end of each critical band.

no	index of Table F&CB	frequency [Hz]	Bark [z]
0	2	86,13	0,850
1	5	215,33	2,112
2	7	301,46	2,934
3	10	430,66	4,124
4	12	516,80	4,882
5	15	646,00	5,959
6	18	775,20	6,959
7	21	904,39	7,879
8	25	1076,66	8,987
9	29	1248,93	9,968
10	34	1464,26	11,037
11	39	1679,59	11,957
12	46	1981,05	13,042
13	51	2325,59	14,062
14	55	2670,12	14,909
15	61	3186,91	15,955
16	68	3789,84	16,951
17	74	4478,91	17,905
18	79	5340,23	18,922
19	85	6373,83	19,963
20	92	7579,69	20,972
21	101	9130,08	21,980
22	108	10 335,94	22,576

**Table D.2c. - Critical band boundaries**

This table is valid for Layer I at a sampling rate of 24 kHz.  
The frequencies represent the top end of each critical band.

no	index of Table F&CB	frequency [Hz]	Bark [z]
0	2	93,75	0,925
1	4	187,50	1,842
2	7	328,13	3,184
3	9	421,88	4,045
4	11	515,63	4,872
5	14	656,25	6,041
6	17	796,88	7,119
7	20	937,50	8,103
8	23	1078,13	8,996
9	27	1265,63	10,057
10	31	1453,13	10,986
11	36	1687,50	11,988
12	42	1968,75	13,002
13	49	2343,75	14,111
14	53	2718,75	15,018
15	58	3187,50	15,956
16	65	3843,75	17,032
17	72	4500,00	17,932
18	77	5437,50	19,028
19	82	6375,00	19,964
20	89	7687,50	21,052
21	97	9187,50	22,012
22	108	11 250,00	22,941

**Table D.2d. - Critical band boundaries**

This table is valid for Layer II at a sampling rate of 16 kHz.  
The frequencies represent the top end of each critical band.

no	index of Table F&CB	frequency [Hz]	Bark [z]
0	6	93,75	0,925
1	13	203,13	1,994
2	20	312,50	3,037
3	27	421,88	4,045
4	34	531,25	5,006
5	42	656,25	6,041
6	49	781,25	7,004
7	54	937,50	8,103
8	59	1093,75	9,090
9	64	1250,00	9,974
10	71	1468,75	11,058
11	75	1687,50	11,988
12	79	1937,50	12,898
13	85	2312,50	14,027
14	91	2687,50	14,949
15	98	3250,00	16,069
16	103	3875,00	17,078
17	108	4500,00	17,932
18	115	5375,00	18,960
19	123	6375,00	19,964
20	132	7500,00	20,912

**Table D.2e. - Critical band boundaries**

This table is valid for Layer II at a sampling rate of 22,05 kHz.  
The frequencies represent the top end of each critical band.

no	index of Table F&CB	frequency [Hz]	Bark [z]
0	5	107,67	1,062
1	9	193,80	1,903
2	14	301,46	2,934
3	19	409,13	3,929
4	25	538,33	5,067
5	30	646,00	5,959
6	36	775,20	6,959
7	43	925,93	8,025
8	49	1076,66	8,987
9	53	1248,93	9,968
10	58	1464,26	11,037
11	63	1679,59	11,957
12	70	1981,05	13,042
13	75	2325,59	14,062
14	79	2670,12	14,909
15	85	3186,91	15,955
16	92	3789,84	16,951
17	98	4478,91	17,905
18	103	5340,23	18,922
19	109	6373,83	19,963
20	116	7579,69	20,972
21	125	9130,08	21,980
22	132	10 335,94	22,576

**Table D.2f. - Critical band boundaries**

This table is valid for Layer II at a sampling rate of 24 kHz.  
The frequencies represent the top end of each critical band.

no	index of Table F&CB	frequency [Hz]	Bark [z]
0	4	93,75	0,925
1	9	210,94	2,069
2	13	304,69	2,964
3	18	421,88	4,045
4	23	539,06	5,073
5	28	656,25	6,041
6	33	773,44	6,946
7	39	914,06	7,945
8	46	1078,13	8,996
9	51	1265,63	10,057
10	55	1453,13	10,986
11	60	1687,50	11,988
12	66	1968,75	13,002
13	73	2343,75	14,111
14	77	2718,75	15,018
15	82	3187,50	15,956
16	89	3843,75	17,032
17	96	4500,00	17,932
18	101	5437,50	19,028
19	106	6375,00	19,964
20	113	7687,50	21,052
21	121	9187,50	22,012

22	132	11 250,00	22,941
----	-----	-----------	--------

## D.2 Psychoacoustic Model 2 for Lower Sampling Frequencies

Psychoacoustic model 2 for lower sampling frequencies is identical to the psychoacoustic model 2 as described in ISO/IEC 11172-3, with some exceptions. The following tables are used instead of tables C.7.a ... C.8.e, for use with Layer III:

**Table D.3.a -- Sampling\_frequency = 24 kHz long blocks**

no.	FFT-lines	minval	qthr	norm	bval
0	1	24,5	4,532	0,970	0,000
1	1	24,5	4,532	0,755	0,469
2	1	24,5	4,532	0,738	0,937
3	1	24,5	0,904	0,730	1,406
4	1	24,5	0,904	0,724	1,875
5	1	20	0,090	0,723	2,344
6	1	20	0,090	0,723	2,812
7	1	20	0,029	0,723	3,281
8	1	20	0,029	0,718	3,750
9	1	20	0,009	0,690	4,199
10	1	20	0,009	0,660	4,625
11	1	18	0,009	0,641	5,047
12	1	18	0,009	0,600	5,437
13	1	18	0,009	0,584	5,828
14	1	12	0,009	0,531	6,187
15	1	12	0,009	0,537	6,522
16	2	6	0,018	0,857	7,174
17	2	6	0,018	0,858	7,800
18	2	3	0,018	0,853	8,402
19	2	3	0,018	0,824	8,966
20	2	3	0,018	0,778	9,483
21	2	3	0,018	0,740	9,966
22	2	0	0,018	0,709	10,426
23	2	0	0,018	0,676	10,866
24	2	0	0,018	0,632	11,279
25	2	0	0,018	0,592	11,669
26	2	0	0,018	0,553	12,042
27	2	0	0,018	0,510	12,386
28	2	0	0,018	0,513	12,721
29	3	0	0,027	0,608	13,115
30	3	0	0,027	0,673	13,561
31	3	0	0,027	0,636	13,983
32	3	0	0,027	0,586	14,371
33	3	0	0,027	0,571	14,741
34	4	0	0,036	0,616	15,140
35	4	0	0,036	0,640	15,562
36	4	0	0,036	0,597	15,962
37	4	0	0,036	0,538	16,324
38	4	0	0,036	0,512	16,665
39	5	0	0,045	0,528	17,020
40	5	0	0,045	0,516	17,373
41	5	0	0,045	0,493	17,708
42	6	0	0,054	0,499	18,045
43	7	0	0,063	0,525	18,398
44	7	0	0,063	0,541	18,762
45	8	0	0,072	0,528	19,120
46	8	0	0,072	0,510	19,466
47	8	0	0,072	0,506	19,807
48	10	0	0,180	0,525	20,159
49	10	0	0,180	0,536	20,522
50	10	0	0,180	0,518	20,873
51	13	0	0,372	0,501	21,214
52	13	0	0,372	0,496	21,553
53	14	0	0,400	0,497	21,892

54	18	0	1,628	0,495	22,231
55	18	0	1,628	0,494	22,569
56	20	0	1,808	0,497	22,909
57	25	0	22,607	0,494	23,248
58	25	0	22,607	0,487	23,583
59	35	0	31,650	0,483	23,915
60	67	0	605,867	0,482	24,246
61	67	0	605,867	0,524	24,576

Table D.3.b Sampling\_frequency = 22,05 kHz long blocks

no.	FFT-lines	minval	qthr	norm	bval
0	1	24,5	4,532	0,951	0,000
1	1	24,5	4,532	0,700	0,431
2	1	24,5	4,532	0,681	0,861
3	1	24,5	0,904	0,675	1,292
4	1	24,5	0,904	0,667	1,723
5	1	20	0,090	0,665	2,153
6	1	20	0,090	0,664	2,584
7	1	20	0,029	0,664	3,015
8	1	20	0,029	0,664	3,445
9	1	20	0,029	0,655	3,876
10	1	20	0,009	0,616	4,279
11	1	20	0,009	0,597	4,670
12	1	18	0,009	0,578	5,057
13	1	18	0,009	0,541	5,415
14	1	18	0,009	0,575	5,774
15	2	12	0,018	0,856	6,422
16	2	6	0,018	0,846	7,026
17	2	6	0,018	0,840	7,609
18	2	3	0,018	0,822	8,168
19	2	3	0,018	0,800	8,710
20	2	3	0,018	0,753	9,207
21	2	3	0,018	0,704	9,662
22	2	0	0,018	0,674	10,099
23	2	0	0,018	0,640	10,515
24	2	0	0,018	0,609	10,917
25	2	0	0,018	0,566	11,293
26	2	0	0,018	0,535	11,652
27	2	0	0,018	0,531	11,997
28	3	0	0,027	0,615	12,394
29	3	0	0,027	0,686	12,850
30	3	0	0,027	0,650	13,277
31	3	0	0,027	0,611	13,681
32	3	0	0,027	0,567	14,062
33	3	0	0,027	0,520	14,411
34	3	0	0,027	0,513	14,751
35	4	0	0,036	0,557	15,119
36	4	0	0,036	0,584	15,508
37	4	0	0,036	0,570	15,883
38	5	0	0,045	0,579	16,263
39	5	0	0,045	0,585	16,654
40	5	0	0,045	0,548	17,020
41	6	0	0,054	0,536	17,374
42	6	0	0,054	0,550	17,744
43	7	0	0,063	0,532	18,104
44	7	0	0,063	0,504	18,447
45	7	0	0,063	0,496	18,781
46	9	0	0,081	0,516	19,130
47	9	0	0,081	0,527	19,487
48	9	0	0,081	0,516	19,838
49	10	0	0,180	0,497	20,179
50	10	0	0,180	0,489	20,510
51	11	0	0,198	0,502	20,852
52	14	0	0,400	0,502	21,196
53	14	0	0,400	0,491	21,531
54	15	0	0,429	0,497	21,870
55	20	0	1,808	0,504	22,214
56	20	0	1,808	0,504	22,558
57	21	0	1,899	0,495	22,898
58	27	0	24,415	0,486	23,232
59	27	0	24,415	0,484	23,564
60	36	0	32,554	0,483	23,897
61	73	0	660,124	0,475	24,229
62	18	0	162,770	0,515	24,542



Table D.3.c -- Sampling frequency = 16 kHz long blocks

no.	FFT-lines	minval	qthr	norm	bval
0	2	24,5	9,064	0,997	0,312
1	2	24,5	9,064	0,893	0,937
2	2	24,5	1,808	0,881	1,562
3	2	20	0,181	0,873	2,187
4	2	20	0,181	0,872	2,812
5	2	20	0,057	0,871	3,437
6	2	20	0,018	0,860	4,045
7	2	20	0,018	0,839	4,625
8	2	18	0,018	0,812	5,173
9	2	18	0,018	0,784	5,698
10	2	12	0,018	0,741	6,184
11	2	12	0,018	0,697	6,634
12	2	6	0,018	0,674	7,070
13	2	6	0,018	0,651	7,492
14	2	6	0,018	0,633	7,905
15	2	3	0,018	0,611	8,305
16	2	3	0,018	0,589	8,695
17	2	3	0,018	0,575	9,064
18	3	3	0,027	0,654	9,483
19	3	3	0,027	0,724	9,966
20	3	0	0,027	0,701	10,425
21	3	0	0,027	0,673	10,866
22	3	0	0,027	0,631	11,279
23	3	0	0,027	0,592	11,669
24	3	0	0,027	0,553	12,042
25	3	0	0,027	0,510	12,386
26	3	0	0,027	0,505	12,721
27	4	0	0,036	0,562	13,091
28	4	0	0,036	0,598	13,488
29	4	0	0,036	0,589	13,873
30	5	0	0,045	0,607	14,268
31	5	0	0,045	0,620	14,679
32	5	0	0,045	0,580	15,067
33	5	0	0,045	0,532	15,424
34	5	0	0,045	0,517	15,771
35	6	0	0,054	0,517	16,120
36	6	0	0,054	0,509	16,466
37	6	0	0,054	0,506	16,807
38	8	0	0,072	0,522	17,158
39	8	0	0,072	0,531	17,518
40	8	0	0,072	0,519	17,869
41	10	0	0,090	0,512	18,215
42	10	0	0,090	0,509	18,562
43	10	0	0,090	0,497	18,902
44	12	0	0,108	0,494	19,239
45	12	0	0,108	0,501	19,579
46	13	0	0,117	0,507	19,925
47	14	0	0,252	0,502	20,269
48	14	0	0,252	0,493	20,606
49	16	0	0,289	0,497	20,944
50	20	0	0,572	0,506	21,288
51	20	0	0,572	0,510	21,635
52	23	0	0,658	0,504	21,979
53	27	0	2,441	0,496	22,319
54	27	0	2,441	0,493	22,656
55	32	0	2,894	0,490	22,993
56	37	0	33,458	0,483	23,326
57	37	0	33,458	0,458	23,656
58	12	0	10,851	0,500	23,937

Table D.3.d -- Sampling\_frequency = 24 kHz short blocks

no.	FFT-lines	qthr	norm	SNR (db)	bval
0	1	4,532	0,970	-8,240	0,000
1	1	0,904	0,755	-8,240	1,875
2	1	0,029	0,738	-8,240	3,750
3	1	0,009	0,730	-8,240	5,437
4	1	0,009	0,724	-8,240	6,857
5	1	0,009	0,723	-8,240	8,109
6	1	0,009	0,723	-8,240	9,237
7	1	0,009	0,723	-8,240	10,202
8	1	0,009	0,718	-8,240	11,083
9	1	0,009	0,690	-8,240	11,864
10	1	0,009	0,660	-7,447	12,553
11	1	0,009	0,641	-7,447	13,195
12	1	0,009	0,600	-7,447	13,781
13	1	0,009	0,584	-7,447	14,309
14	1	0,009	0,532	-7,447	14,803
15	1	0,009	0,537	-7,447	15,250
16	1	0,009	0,857	-7,447	15,667
17	1	0,009	0,858	-7,447	16,068
18	1	0,009	0,853	-7,447	16,409
19	2	0,018	0,824	-7,447	17,044
20	2	0,018	0,778	-6,990	17,607
21	2	0,018	0,740	-6,990	18,097
22	2	0,018	0,709	-6,990	18,528
23	2	0,018	0,676	-6,990	18,930
24	2	0,018	0,632	-6,990	19,295
25	2	0,018	0,592	-6,990	19,636
26	3	0,054	0,553	-6,990	20,038
27	3	0,054	0,510	-6,990	20,486
28	3	0,054	0,513	-6,990	20,900
29	4	0,114	0,608	-6,990	21,305
30	4	0,114	0,673	-6,020	21,722
31	5	0,452	0,637	-6,020	22,128
32	5	0,452	0,586	-6,020	22,512
33	5	0,452	0,571	-6,020	22,877
34	7	6,330	0,616	-5,229	23,241
35	7	6,330	0,640	-5,229	23,616
36	11	9,947	0,597	-5,229	23,974
37	17	153,727	0,538	-5,229	24,312

Table D.3.e -- Sampling\_frequency = 22,05 kHz short blocks

no.	FFT-lines	qthr	norm	SNR (db)	bval
0	1	4,532	0,952	-8,240	0,000
1	1	0,904	0,700	-8,240	1,723
2	1	0,029	0,681	-8,240	3,445
3	1	0,009	0,675	-8,240	5,057
4	1	0,009	0,667	-8,240	6,422
5	1	0,009	0,665	-8,240	7,609
6	1	0,009	0,664	-8,240	8,710
7	1	0,009	0,664	-8,240	9,662
8	1	0,009	0,664	-8,240	10,515
9	1	0,009	0,655	-8,240	11,293
10	1	0,009	0,616	-7,447	12,009
11	1	0,009	0,597	-7,447	12,625
12	1	0,009	0,578	-7,447	13,210
13	1	0,009	0,541	-7,447	13,748
14	1	0,009	0,575	-7,447	14,241
15	1	0,009	0,856	-7,447	14,695
16	1	0,009	0,846	-7,447	15,125
17	1	0,009	0,840	-7,447	15,508
18	1	0,009	0,822	-7,447	15,891
19	2	0,018	0,800	-7,447	16,537
20	2	0,018	0,753	-6,990	17,112
21	2	0,018	0,704	-6,990	17,620
22	2	0,018	0,674	-6,990	18,073
23	2	0,018	0,640	-6,990	18,470
24	2	0,018	0,609	-6,990	18,849
25	3	0,027	0,566	-6,990	19,271
26	3	0,027	0,535	-6,990	19,741
27	3	0,054	0,531	-6,990	20,177
28	3	0,054	0,615	-6,990	20,576
29	3	0,054	0,686	-6,990	20,950
30	4	0,114	0,650	-6,020	21,316
31	4	0,114	0,612	-6,020	21,699
32	5	0,452	0,567	-6,020	22,078
33	5	0,452	0,520	-6,020	22,438
34	5	0,452	0,513	-5,229	22,782
35	7	6,330	0,557	-5,229	23,133
36	7	6,330	0,584	-5,229	23,484
37	7	6,330	0,570	-5,229	23,828
38	19	171,813	0,578	-4,559	24,173

Table D.3.f -- Sampling frequency = 16 kHz short blocks

no.	FFT-lines	qthr	norm	SNR (db)	bval
0	1	4,532	0,997	-8,240	0,000
1	1	0,904	0,893	-8,240	1,250
2	1	0,090	0,881	-8,240	2,500
3	1	0,029	0,873	-8,240	3,750
4	1	0,009	0,872	-8,240	4,909
5	1	0,009	0,871	-8,240	5,958
6	1	0,009	0,860	-8,240	6,857
7	1	0,009	0,839	-8,240	7,700
8	1	0,009	0,812	-8,240	8,500
9	1	0,009	0,784	-8,240	9,237
10	1	0,009	0,741	-7,447	9,895
11	1	0,009	0,697	-7,447	10,500
12	1	0,009	0,674	-7,447	11,083
13	1	0,009	0,651	-7,447	11,604
14	1	0,009	0,633	-7,447	12,107
15	1	0,009	0,611	-7,447	12,554
16	1	0,009	0,589	-7,447	13,000
17	1	0,009	0,575	-7,447	13,391
18	1	0,009	0,654	-7,447	13,781
19	2	0,018	0,724	-7,447	14,474
20	2	0,018	0,701	-6,990	15,096
21	2	0,018	0,673	-6,990	15,667
22	2	0,018	0,631	-6,990	16,177
23	2	0,018	0,592	-6,990	16,636
24	2	0,018	0,553	-6,990	17,057
25	2	0,018	0,510	-6,990	17,429
26	2	0,018	0,506	-6,990	17,786
27	3	0,027	0,562	-6,990	18,177
28	3	0,027	0,598	-6,990	18,597
29	3	0,027	0,589	-6,990	18,994
30	3	0,027	0,607	-6,020	19,352
31	3	0,027	0,620	-6,020	19,693
32	4	0,072	0,580	-6,020	20,066
33	4	0,072	0,532	-6,020	20,461
34	4	0,072	0,517	-5,229	20,841
35	5	0,143	0,517	-5,229	21,201
36	5	0,143	0,509	-5,229	21,549
37	6	0,172	0,506	-5,229	21,911
38	7	0,633	0,522	-4,559	22,275
39	7	0,633	0,531	-4,559	22,625
40	8	0,723	0,519	-3,980	22,971
41	10	9,043	0,512	-3,980	23,321

**Table D.4 -- Tables for converting threshold calculation partitions to scalefactor bands****Table D.4.a -- Sampling\_frequency = 24 kHz long blocks**

no. sb	cbw	bu	bo	w1	w2
0	3	0	4	1,000	0,056
1	3	4	7	0,944	0,611
2	4	7	11	0,389	0,167
3	3	11	14	0,833	0,722
4	3	14	17	0,278	0,639
5	2	17	19	0,361	0,417
6	3	19	22	0,583	0,083
7	2	22	24	0,917	0,750
8	3	24	27	0,250	0,417
9	3	27	30	0,583	0,648
10	3	30	33	0,352	0,611
11	3	33	36	0,389	0,625
12	4	36	40	0,375	0,144
13	3	40	43	0,856	0,389
14	3	43	46	0,611	0,160
15	3	46	49	0,840	0,217
16	3	49	52	0,783	0,184
17	2	52	54	0,816	0,886
18	3	54	57	0,114	0,313
19	2	57	59	0,687	0,452
20	1	59	60	0,548	0,908

**Table D.4.b -- Sampling\_frequency = 22,05 kHz long blocks**

no. sb	cbw	bu	bo	w1	w2
0	3	0	4	1,000	0,056
1	3	4	7	0,944	0,611
2	4	7	11	0,389	0,167
3	3	11	14	0,833	0,722
4	3	14	17	0,278	0,139
5	1	17	18	0,861	0,917
6	3	18	21	0,083	0,583
7	3	21	24	0,417	0,250
8	3	24	27	0,750	0,805
9	3	27	30	0,194	0,574
10	3	30	33	0,426	0,537
11	3	33	36	0,463	0,819
12	4	36	40	0,180	0,100
13	3	40	43	0,900	0,468
14	3	43	46	0,532	0,623
15	3	46	49	0,376	0,450
16	3	49	52	0,550	0,552
17	3	52	55	0,448	0,403
18	2	55	57	0,597	0,643
19	2	57	59	0,357	0,722
20	2	59	61	0,278	0,960

Table D.4.c -- Sampling\_frequency = 16 kHz long blocks

no. sb	cbw	bu	bo	w1	w2
0	1	0	2	1,000	0,528
1	2	2	4	0,472	0,305
2	2	4	6	0,694	0,083
3	1	6	7	0,917	0,861
4	2	7	9	0,139	0,639
5	2	9	11	0,361	0,417
6	3	11	14	0,583	0,083
7	2	14	16	0,917	0,750
8	3	16	19	0,250	0,870
9	3	19	22	0,130	0,833
10	4	22	26	0,167	0,389
11	4	26	30	0,611	0,478
12	4	30	34	0,522	0,033
13	3	34	37	0,967	0,917
14	4	37	41	0,083	0,617
15	3	41	44	0,383	0,995
16	4	44	48	0,005	0,274
17	3	48	51	0,726	0,480
18	3	51	54	0,519	0,261
19	2	54	56	0,739	0,884
20	2	56	58	0,116	1,000

Table D.4.d -- Sampling\_frequency = 24 kHz short blocks

no. sb	cbw	bu	bo	w1	w2
0	2	0	3	1,000	0,167
1	2	3	5	0,833	0,833
2	3	5	8	0,167	0,500
3	3	8	11	0,500	0,167
4	4	11	15	0,833	0,167
5	4	15	19	0,833	0,583
6	3	19	22	0,417	0,917
7	4	22	26	0,083	0,944
8	4	26	30	0,055	0,042
9	2	30	32	0,958	0,567
10	3	32	35	0,433	0,167
11	2	35	37	0,833	0,618

**Table D.4.e -- Sampling\_frequency = 22,05 kHz short blocks**

<b>no. sb</b>	<b>cbw</b>	<b>bu</b>	<b>bo</b>	<b>w1</b>	<b>w2</b>
0	2	0	3	1,000	0,167
1	2	3	5	0,833	0,833
2	3	5	8	0,167	0,500
3	3	8	11	0,500	0,167
4	4	11	15	0,833	0,167
5	5	15	20	0,833	0,250
6	3	20	23	0,750	0,583
7	4	23	27	0,417	0,055
8	3	27	30	0,944	0,375
9	3	30	33	0,625	0,300
10	3	33	36	0,700	0,167
11	2	36	38	0,833	1,000

**Table D.4.f -- Sampling\_frequency = 16 kHz short blocks**

<b>no. sb</b>	<b>cbw</b>	<b>bu</b>	<b>bo</b>	<b>w1</b>	<b>w2</b>
0	2	0	3	1,000	0,167
1	2	3	5	0,833	0,833
2	3	5	8	0,167	0,500
3	3	8	11	0,500	0,167
4	4	11	15	0,833	0,167
5	5	15	20	0,833	0,250
6	4	20	24	0,750	0,250
7	5	24	29	0,750	0,055
8	4	29	33	0,944	0,375
9	4	33	37	0,625	0,472
10	3	37	40	0,528	0,937
11	1	40	41	0,062	1,000

## Annex E

(Informative)

### List of patent holders

The user's attention is called to the possibility that - for some of the processes specified in this Recommendation | International Standard - conformance with this International Standard/Recommendation may require use of an invention covered by patent rights.

By publication of this Recommendation | International Standard, no position is taken with respect to the validity of this claim or of any patent rights in connection therewith. However, each company listed in this annex has undertaken to file with the Information Technology Task Force (ITTF) a statement of willingness to grant a license under such rights that they hold on reasonable and non-discriminatory terms and conditions to applicants desiring to obtain such a license.

Information regarding such patents can be obtained from the following organisations.

The table summarises the formal patent statements received and indicates the parts of the standard to which the statement applies. The list includes all organisations that have submitted informal statements. However, if no "X" is present, no formal statement has yet been received from that organisation.



Company	ISO/IEC 13818-2	ISO/IEC 13818-3	ISO/IEC 13818-1
AT&T	X	X	X
BBC Research Department			
Bellcore	X		
Belgian Science Policy Office	X	X	X
BOSCH	X	X	X
CCETT			
CSELT	X		
David Sarnoff Research Center	X	X	X
Deutsche Thomson-Brandt GmbH	X	X	X
France Telecom CNET			
Fraunhofer Gesellschaft		X	X
GC Technology Corporation	X	X	X
General Instruments			
Goldstar			
Hitachi, Ltd.			
International Business Machines Corporation	X	X	X
IRT		X	
KDD	X		
Massachusetts Institute of Technology	X	X	X
Matsushita Electric Industrial Co., Ltd.	X	X	X
Mitsubishi Electric Corporation			
National Transcommunications Limited			
NEC Corporation		X	
Nippon Hoso Kyokai	X		
Nippon Telegraph and Telephone	X		
Nokia Research Center	X		
Norwegian Telecom Research	X		
Philips Consumer Electronics	X	X	X
OKI			
Qualcomm Incorporated	X		
Royal PTT Nederland N.V., PTT Research (NL)	X	X	X
Samsung Electronics			
Scientific Atlanta	X	X	X
Siemens AG	X		
Sharp Corporation			
Sony Corporation			
Texas Instruments			
Thomson Consumer Electronics			
Toshiba Corporation	X		
TV/Com	X	X	X
Victor Company of Japan Limited			